

When it comes to your
SOLID CARBIDE
Tooling needs...



The Brand Name
you can Trust...

MICRO 100 Tool Corporation
has built a reputation for manufacturing high
quality solid carbide tooling for over 50 years.

All of our tools are manufactured from more
than just a micro-grain of excellent quality.
Our proprietary micrograin carbide features the
highest transverse rupture strength and is
highly shock resistant.

Will not Chip or Break
under normal machining conditions and is
unexcelled in interrupted cutting.

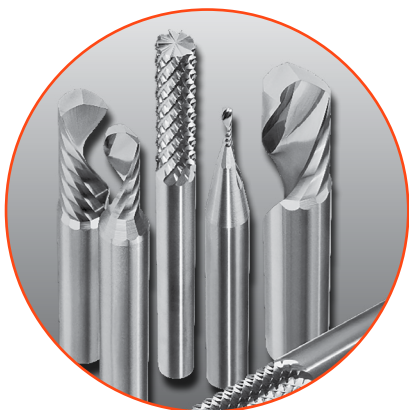
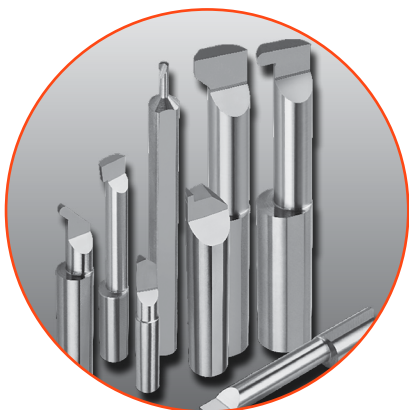

Contact us or your local authorized Distributor today for more details.

BACK CHAMFERING TOOLS	Solid Carbide	page 88
BLANKS	Half-Round Blanks	page 181
	Half-Round Blanks (Metric)*	page 271
	Round Blanks	page 182
	Round Blanks (Metric)	page 272
	Assorted Blanks	pages 183 - 185
	Split-End Blanks	pages 106 - 107
	Split-End Blanks (Metric)	page 270
	Quik-Change Blanks	page 67
BORING TOOLS	Brazed	page 176
	Standard Miniature Solid Carbide Boring Tools	page 11
	Standard Miniature Solid Carbide Boring Tools (Metric)	page 201
	Standard Solid Carbide Boring Tools	pages 12 - 15
	Standard Solid Carbide Boring Tools (Metric)	pages 202, 203
	Helical Rake Boring Tools	pages 16, 17
	Quik-Change Miniature Boring Tools	page 40
	Quik-Change Boring Tools	pages 41 - 49
BRAZED TOOLING	Quik-Change Reverse Boring Tools	page 46
	Boring Bars	pages 176
	Box Turning Tools	page 172
	Cut-Off Blades	pages 173, 174
	Forming Tools	pages 164, 169, 170
	Full Radius Grooving Tools	pages 168, 171
	Internal Threading Tools	page 167
	Radius Tools	pages 168 - 170
	Screw Machine Tools	page 175
	Threading Tools	pages 164 - 167
Turning Tools	pages 164-166, 172, 175	
COMBINED DRILLS and COUNTERSINKS	Quik-Change Tools	page 66, 98
COUNTERSINKS and CHAMFERING TOOLS	Quik-Change Tools	page 64
	Standard Solid Carbide Tools	page 97
DIE SINK CUTTERS	Standard Solid Carbide Tools	page 94
DOVETAIL CUTTERS	Standard Solid Carbide Tools	page 92
DRILL MILLS	Standard Solid Carbide Drill Mills	page 148
	Solid Carbide Drill Mills (Metric)	page 254
DRILLS	Spade Drills	page 99
	Quik-Change Spade Drills	page 65
	Spotting and Centering Drills	page 100
	Quik-Change Spotting and Centering Drills	page 63
	Jobber Length Drills	page 101
END MILLS (SQUARE NOSE)	Hard Milling Miniatures	pages 113 - 121
	Hard Milling Miniatures (Metric)	pages 224 - 228
	2, 3, 4 and 5 Flutes	pages 122 - 134, 136 - 145
	2, 3, 4 and 5 Flutes (Metric)	pages 234 - 255
	6 Flutes	page 135
6 Flutes (Metric)	page 243	

*Style HRM by SPECIAL ORDER ONLY once current Inventories are depleted.

END MILLS (SQUARE NOSE)	Miniatures	page 113
	Miniatures (Metric)	page 233
	Roughing (Shredders)	page 136
	Roughing (Shredders) (Metric)	pages 244, 247
	V-Hemoths - 4 Flutes	pages 137, 139, 141, 143
	V-Hemoths - 4 Flutes (Metric)	pages 246, 248, 250
	V-Hemoths - 5 Flutes	pages 138, 140, 142, 143
	V-Hemoths - 5 Flutes (Metric)	pages 246
	Long Length	pages 143 - 145
Long Length (Metric)	pages 251, 252	
Tapered	page 146	
END MILLS (BALL NOSE)	Hard Milling Miniatures	pages 149 - 151
	Hard Milling Miniatures (Metric)	pages 256, 257
	Miniatures	page 153
	Miniatures (Metric)	page 231
	2, 3, 4 Flute	pages 154, 156, 157
	2, 3, 4 Flute (Metric)	page 263
	Long Lengths	pages 155, 158
	Long Lengths (Metric)	pages 266, 267
	V-Hemoths - 4 Flutes (Metric)	page 262
Spherical Ball	page 159	
Spherical Ball (Metric)	page 264	
END MILLS (CORNER ROUNDING)	Corner Rounding	page 147
	Corner Rounding (Metric)	page 253
ENGRAVING TOOLS	Standard Solid Carbide Tools	pages 102 - 105
	Standard Solid Carbide Tools (Metric)	pages 215 - 217
GROOVING TOOLS	Brazed Grooving Tools	page 171
	Standard Solid Carbide Retaining Ring	pages 18 - 20
	Standard Solid Carbide Retaining Ring (Metric)	pages 204, 205
	Standard Solid Carbide Face Grooving Tools	page 25
	Standard Solid Carbide O-Ring Groove Tools	page 24
	Standard Solid Carbide Undercut Groove Tools	page 26
	Standard Solid Carbide Undercut and Profile Groove Tools	page 27
	Quik-Change Miniature Retaining Ring Grooving Tools	page 51
	Quik-Change Miniature Full Radius Grooving Tools	page 55
Quik-Change Full Radius Grooving Tools	pages 55 - 58	
Quik-Change Face Grooving Tools	page 59	
INDEXABLE INSERTS	Solid Carbide Insert Blanks	page 186
	ANSI Standard	page 198
KEYSEAT CUTTERS	Standard Solid Carbide Tools	pages 89 - 91
M100 DEX INDEXABLE TOOLING	Turning and Facing Tools	pages 189, 190
	Turning and Chamfering Tools	page 191
	Threading Tools and Coolant-Thru Boring Bars	pages 192, 193
	Millling Tools	page 194
	Indexable Inserts and Accessories	page 198
Indexable Tooling Sets	pages 195 - 197	

MOLDMAKING RUNNER CUTTERS	Solid Carbide, Single End Moldmaking Runner Cutters	page 93
PROFILING TOOLS	Solid Carbide Undercut and Profile Groove Tools	page 26
	Quik-Change Profiling Tools	pages 48 - 50
Quik-CHANGE TOOLING ACCESSORIES	Centerline Indicating Tools	page 80
	Locking/Locating Screws	page 80
	Button Head Screws	page 80
	Hex Screws	page 80
	Hex Wrench	page 80
	"T" Style Hex Wrench	page 80
RADIUS TOOLS	One or Two Split End Radius Tools	page 107
	One or Two Split End Radius Tools (Metric)	page 218
ROUTERS	Solid Carbide Single Flute Routers	page 95
	Solid Carbide Single Flute Routers (Metric)	pages 212, 213
	Solid Carbide Diamond Cut Fluting Pattern Routers	page 96
SHARPENER	Speedy Sharp	page 109
SLITTING BLADE	Solid Carbide Slitting Blade	page 108
TANGENTIAL BLADES	Solid Carbide Tangential Blades	page 108
THREADING TOOLS	Brazed Threading Tools	pages 165 - 167
	Standard Solid Carbide Threading Tools	pages 28, 29, 35
	Quik-Change Threading Tools	pages 60 - 62
	Solid Carbide ACME Threading Tools	pages 30, 31
	Standard Solid Carbide Threading Tools (Metric)	page 206
	Thread Mills	pages 84 - 87
Thread Mills (Metric)	page 211	
THREAD RELIEF TOOLS	Solid Carbide Thread Relief Tools	pages 32, 88
TOOL HOLDERS	Tool Holders for Standard Solid Carbide Tools	page 33
	Tool Holders for Standard Solid Carbide Tools (Metric)	page 207
	Quik-Change Tool Holders	pages 69, 70, 72, 75 - 78
	Quik-Change Tool Holders (Metric)	pages 69, 71, 73, 79
	Quik-Change Tool Accessories	page 80
TOOLING SETS	Miniature Boring Tool Set	page 35
	Boring Tool Sets	page 34
	Retaining Ring Grooving Tool Sets	page 35
	Internal Threading Tool Sets	page 35
	DC Tool Set	page 98
	M100 DEX Indexable Tool Sets	pages 195 - 197
Concave/Convex & Radius Tool Sets	pages 169 - 170	

**Need Solutions for
Speeds, Feeds, and Depth of Cuts...**

**Please refer to our
Technical Data Section
on pages 274 - 306**

**or contact our Technical Sales Team at
1-800-421-8065**



Prefix	Page(s) No.	Prefix	Page(s) No.	Prefix	Page(s) No.
Carbide Blanks	179	CS	97	IAT	31
Indexable Tooling	187	CT	167	IDLT/ IDRT	167
AECM	234	D	165	IT/ ITL	28, 29
AELM	252	DC	98	IT sets	35
AEMM	235	DCM	219	ITM	206
AL	164	DM	148	KC	89 - 91
ALMM	251	DMM	254	KS-1 "Speedy Sharp"	109
AMRM	232	DR	101	LC	175
AR	164	DSC	94	LT	175
ARMM	239	DT	92	LTR	32
ARC	124,133,134	E	166	MBB	11
ARM	123, 132	EL	166	MBBM	201
ASM	122, 132	EMH	135	MBC	88
ASMM	238	EMHM	243	MEF	114 - 121
BB/ BBL / BB-S	12-15	EMS	129	MEFM	224 - 228
BB SETS	34	EMSM	236	MMBM	260, 261
BBM	202, 203	ER	166	MMRM	229, 230
BEF	149 - 151	FG	25	MRF/ MRT	93
BEFM	256, 257	FR	21-23	MTR	88
BEL	158	FRT	168	OR	24
BELM	266	GEL	144	PZ-1	108
BEM	156, 157	GEC	127, 128	QBB	41 - 43
BEMM	263	GELM	255	QBM	47
BL	164	GEM	125, 126	QBT	44 - 45
BLR	155	GEMM	237	Quik-Change Accessories	80
BLRM	267	GLR	145	QCS	64
BMR	152	GLRM	259	QDC	66
BMRM	231	GR/GS	171	QDH/QDS/QDSM	69
BMS	153	HBB	16, 17	QFG	59
BMSM	231	HMBM	265	QFR	56 - 58
BR	164	HMCM	245	QI	68
BT/ BTL	172	HMRM	240	QIT	60-62
C	165	HMSM	240	QMBB	40
CRE	147	HMUM	241	QMFR	55
CREM	253	HR	181	QMRR	51
CRT	168	HRM	271	QPF	48 - 49

QPR	50	RSF	107	SHR	136
QRB	46	RSFM	218	SME	113
QRR	52 - 54	RSM	270	SHRM	247
QSD	65	RT	175	SPD	100
QSG	78	RTC	102	SR	182
QSP	67	RTCM	215	SRM	272
QSPD	63	RXD	170	T	174
QSR	67	RXL	170	TANG	108
QTC	72	SALM	244	TBB / TBBL	177
QTCM	73	SARM	244	TH	33
QTH	70	SAT	30	THM	207
QTHM	71, 79	SBM	159	TM	84 - 87
QZST	75 - 77	SBMM	264	TMM	211
RAD / RAL	169	SD	99	TRG	176
RDA - RDE	96	SDH	131	TSM	146
RC	175	SDHM	242	UC	26
RME	113	SEM	130	UP	27
RMEM	233	SFA	95	VHBM	262
RNC	104, 105	SFAM	214	VHM	141, 142
RNCM	217	SFBM	258	VHMM	248 - 249
RR Sets	35	SFL	95	VHS	139 - 140
RR/RRL	18-20	SFLM	212, 213	VHSM	246
RRM	204 - 205	SFP	95	VLM	143
RS	106	SFPM	212, 213	VLR	137, 138
RSC	103, 105	SHL	136	VLRM	250
RSCM	216	SHLM	247		

For current pricing and availability please visit our website at www.micro100.com

Standard Boring Type Tools	pages 9-36	A
Micro-Quik "Quik-Change" Tooling System/Accessories	pages 37-80	B
Solid Carbide Specialty Tools	pages 81-110	C
End Mills - Straight / Ball Nose	pages 111-160	D
Brazed Carbide Tools	pages 161-178	E
Carbide Blanks	pages 179-186	F
Indexable Carbide Insert Tools	pages 187-198	G
Standard Boring Type Tools - Metric	pages 199-208	H
Solid Carbide Specialty Tools - Metric	pages 209-220	I
End Mills - Straight / Ball Nose - Metric	pages 221-268	J
Carbide Blanks - Metric	pages 269-272	K
Technical Data	pages 273-306	L

For current pricing and availability please visit our website at www.micro100.com

Check Stock and List Price with our... **"Stock Checker"** on our website:

www.micro100.com

this feature is located on our home page (as shown below) Simple, Quick & Easy!

3 EASY STEPS!

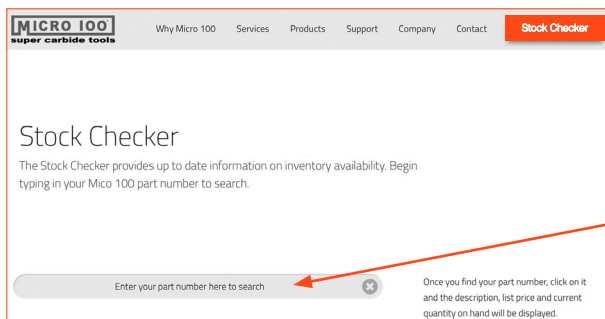
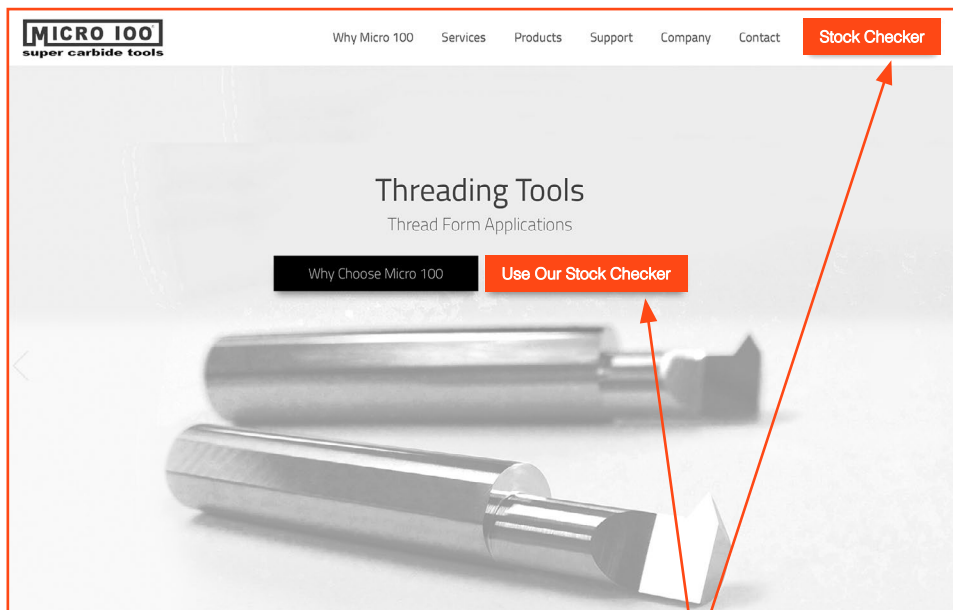

1 Select "Stock Checker" and click.

2 Enter the Part Number.

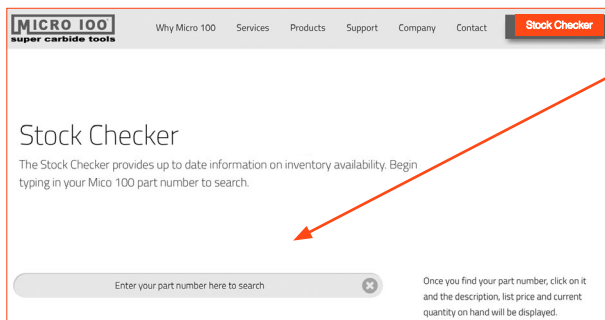

3 The Part number and information will appear.

World Class Quality
Through Manufacturing Excellence

MICRO 100®
super carbide tools

Combined with Superior Strength
& Wear Characteristics Provides Unmatched High
Performance Productivity at it's BEST!



DON'T SEE WHAT YOU NEED?
The Item(s) you need may have been discontinued and will be labeled
"(♦ WHILE SUPPLIES LAST - Discontinued)"
We may have "Limited" inventory on some discontinued. Please call our customer service today for more details.



SET CONVENIENCE!
See page 34

- Miniature Boring Tools
- Boring Tools
- Retaining Ring Grooving Tools
- Full Radius Grooving Tools
- Face Grooving Tools
- "O" Ring Grooving Tools
- Undercut and Profiling Tools
- Internal Threading Tools
- Stub ACME Threading Tools
- Internal ACME Tools
- Thread Relief Tools
- Tool Holders
- Sets



WILL NOT CHIP OR BREAK
UNDER NORMAL MACHINING CONDITIONS



A

Miniature Boring Tools

Style MBB
page 11

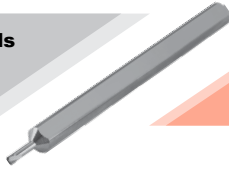

Undercut & Profiling Tools

Style UP
page 27

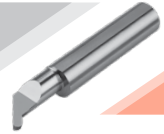

Boring Tools

Style BB/BBL/BBS
pages 12-15

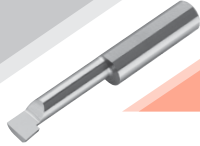

Internal Threading Tools

Style IT & ITL
pages 28, 29

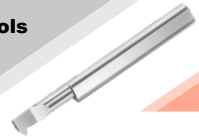

Helical Back Rake Boring Tools

Style HBB
pages 16, 17

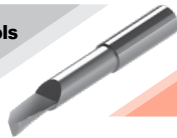

Stub ACME Threading Tools

Style SAT
page 30

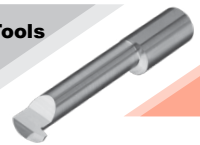

Retaining Ring Grooving Tools

Style RR & RRL
pages 18-20

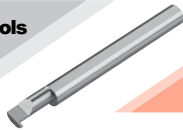

Internal ACME Threading Tools

Style IAT
page 31



Full Radius Grooving Tools

Style FR
pages 21-23

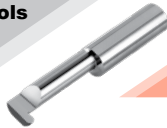

Thread Relief Tools

Style LTR
page 32

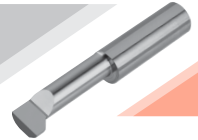

"O" Ring Grooving Tools

Style OR
page 24

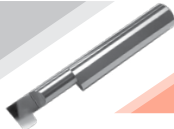

Heat Treated Tool Holders

Style TH
page 33

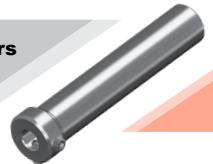

Face Grooving Tools

Style FG
page 25

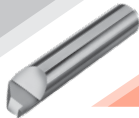

Tool Sets

page 34, 35



Undercut Grooving Tools

Style UC
page 26



A

Tolerances:

Shank Diameter: $-.0001"-.0003"$
Minimum Bore Diameter: $-.002"$
Maximum Bore Depth: $+.010"-0"$
Overall Length: $\pm .015"$

All MBB Tools Manufactured with a Sharp Point

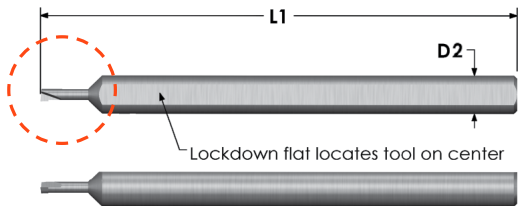
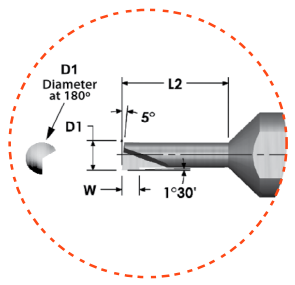
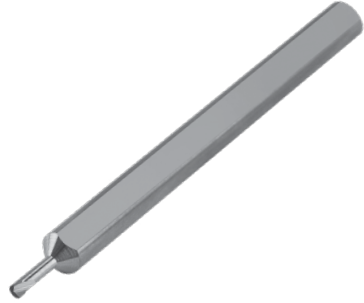
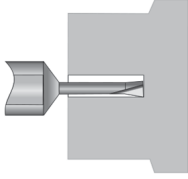

AITiN – Add "X" to the end of Catalog No.

MBB Catalog No.	Minimum Bore Diameter (D1)	Maximum Bore Depth (L2)	Overall Length (L1)
	inch	inch	inch
1/8" Shanks - D2			
MBB-015050	.015	.050	1.500
MBB-020075	.020	.075	1.500
MBB-025100	.025	.100	1.500
MBB-030100	.030	.100	1.500
MBB-035100	.035	.100	1.500
MBB-035150	.035	.150	1.500
MBB-040100	.040	.100	1.500
MBB-040150	.040	.150	1.500
MBB-040200	.040	.200	1.500
MBB-045100	.045	.100	1.500
MBB-045150	.045	.150	1.500
MBB-045200	.045	.200	1.500



Tool Sets on Page 34

A

Tolerances:

Shank Diameter: -.0001"-.0003"
 Minimum Bore Diameter: 0-.005"
 Maximum Bore Depth: +.050"-.000"
 Overall Length: ±.015"
 Tool Radius:
 1/8" Shanks: .003"-.006"
 3/16"-1/2" Shanks: .006"-.008"
 BB-S: 0" Radius

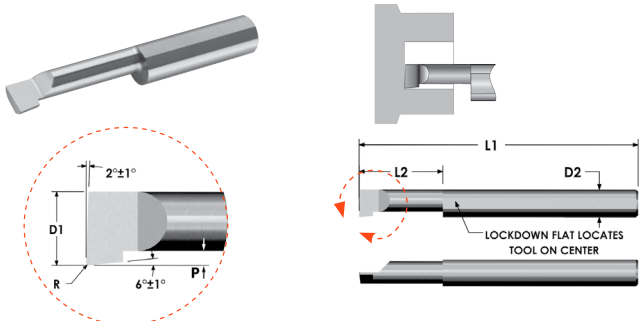

AITN – Add “X” to the end of Catalog No.

TiN – Add “G” to the end of Catalog No.

Other sizes quoted upon request.

BB	BBL	Minimum Bore Diameter (D1)	Maximum Bore Depth (L2)	Projection (P)	Tool Radius (R)	Overall Length (L1)	BBS	Tool Radius (R)
RIGHT Hand Catalog No.	LEFT Hand Catalog No.	inch	inch	inch	inch	inch	Sharp Point Catalog No.	inch
1/8" Shanks – D2								
BB-050150	BBL-050150	.050	.150	.013	.003 - .006	1.500	BB-050150S	0
BB-050200	BBL-050200 ♦	.050	.200	.013	.003 - .006	1.500	BB-050200S	0
BB-050300	BBL-050300 ♦	.050	.300	.013	.003 - .006	1.500	BB-050300S	0
BB-050400	BBL-050400	.050	.400	.013	.003 - .006	1.500	BB-050400S	0
BB-060150	BBL-060150	.060	.150	.015	.003 - .006	1.500	BB-060150S	0
BB-060200	BBL-060200	.060	.200	.015	.003 - .006	1.500	BB-060200S	0
BB-060300	BBL-060300	.060	.300	.015	.003 - .006	1.500	BB-060300S	0
BB-060400	BBL-060400 ♦	.060	.400	.015	.003 - .006	1.500	BB-060400S	0
BB-060500	–	.060	.500	.015	.003 - .006	1.500	BB-060500S	0
BB-080150	BBL-080150 ♦	.080	.150	.020	.003 - .006	1.500	BB-080150S	0
BB-080200	BBL-080200	.080	.200	.020	.003 - .006	1.500	BB-080200S	0
BB-080300	BBL-080300	.080	.300	.020	.003 - .006	1.500	BB-080300S	0
BB-080400	BBL-080400	.080	.400	.020	.003 - .006	1.500	BB-080400S	0
BB-080500	BBL-080500	.080	.500	.020	.003 - .006	1.500	BB-080500S	0
BB-080600	–	.080	.600	.020	.003 - .006	1.500	BB-080600S	0
BB-100150	BBL-100150	.100	.150	.025	.003 - .006	1.500	BB-100150S	0
BB-100200	BBL-100200 ♦	.100	.200	.025	.003 - .006	1.500	BB-100200S	0
BB-100300	BBL-100300	.100	.300	.025	.003 - .006	1.500	BB-100300S	0
BB-100400	BBL-100400 ♦	.100	.400	.025	.003 - .006	1.500	BB-100400S	0
BB-100500	BBL-100500	.100	.500	.025	.003 - .006	1.500	BB-100500S	0
BB-100600	BBL-100600 ♦	.100	.600	.025	.003 - .006	1.500	BB-100600S	0
BB-100700	BBL-100700	.100	.700	.025	.003 - .006	1.500	BB-100700S	0
BB-110150	BBL-110150	.110	.150	.028	.003 - .006	1.500	BB-110150S	0
BB-110200	BBL-110200 ♦	.110	.200	.028	.003 - .006	1.500	BB-110200S	0
BB-110300	BBL-110300	.110	.300	.028	.003 - .006	1.500	BB-110300S	0
BB-110400	BBL-110400	.110	.400	.028	.003 - .006	1.500	BB-110400S	0
BB-110500	BBL-110500 ♦	.110	.500	.028	.003 - .006	1.500	BB-110500S	0
BB-110600	BBL-110600	.110	.600	.028	.003 - .006	1.500	BB-110600S	0
BB-110700	BBL-110700	.110	.700	.028	.003 - .006	1.500	BB-110700S	0
3/16" Shanks – D2								
BB-120250	BBL-120250	.120	.250	.030	.006 - .008	2.000	BB-120250S	0
BB-120350	BBL-120350 ♦	.120	.350	.030	.006 - .008	2.000	BB-120350S	0
BB-120500	BBL-120500	.120	.500	.030	.006 - .008	2.000	BB-120500S	0
BB-120600	BBL-120600	.120	.600	.030	.006 - .008	2.000	BB-120600S	0
BB-120700	BBL-120700	.120	.700	.030	.006 - .008	2.000	BB-120700S	0
BB-120800	BBL-120800 ♦	.120	.800	.030	.006 - .008	2.000	BB-120800S	0

♦ WHILE SUPPLIES LAST - Discontinued

Tool Sets on Page 34

A

Tolerances:

Shank Diameter: -.0001"- .0003"
 Minimum Bore Diameter: 0- .005"
 Maximum Bore Depth: +.050"- .000"
 Overall Length: ±.015"
 Tool Radius:
 1/8" Shanks: .003"- .006"
 3/16"-1/2" Shanks: .006"- .008"
 BB-S: 0" Radius

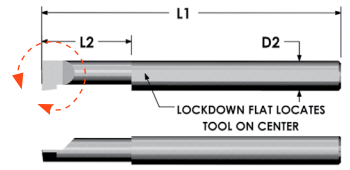
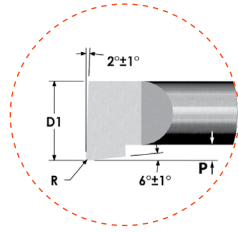
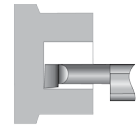
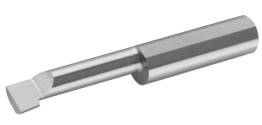

AiTIN – Add “X” to the end of Catalog No.

TIN – Add “G” to the end of Catalog No.

Other sizes quoted upon request.

BB	BBL	Minimum Bore Diameter (D1)	Maximum Bore Depth (L2)	Projection (P)	Tool Radius (R)	Overall Length (L1)	BBS	Tool Radius (R)
RIGHT Hand Catalog No.	LEFT Hand Catalog No.	inch	inch	inch	inch	inch	Sharp Point Catalog No.	inch
3/16" Shanks – D2								
BB-140250	BBL-140250	.140	.250	.035	.006 - .008	2.000	BB-140250S	0
BB-140400	BBL-140400	.140	.400	.035	.006 - .008	2.000	BB-140400S	0
BB-140500	BBL-140500	.140	.500	.035	.006 - .008	2.000	BB-140500S	0
BB-140600	BBL-140600	.140	.600	.035	.006 - .008	2.000	BB-140600S	0
BB-140700	BBL-140700	.140	.700	.035	.006 - .008	2.000	BB-140700S	0
BB-140750	BBL-140750 ♦	.140	.750	.035	.006 - .008	2.000	BB-140750S	0
BB-140800	BBL-140800	.140	.800	.035	.006 - .008	2.000	BB-140800S	0
BB-160250	BBL-160250 ♦	.160	.250	.040	.006 - .008	2.000	BB-160250S	0
BB-160400	BBL-160400 ♦	.160	.400	.040	.006 - .008	2.000	BB-160400S	0
BB-160500	BBL-160500	.160	.500	.040	.006 - .008	2.000	BB-160500S	0
BB-160600	BBL-160600	.160	.600	.040	.006 - .008	2.000	BB-160600S	0
BB-160750	BBL-160750 ♦	.160	.750	.040	.006 - .008	2.000	BB-160750S	0
BB-160900	BBL-160900	.160	.900	.040	.006 - .008	2.000	BB-160900S	0
BB-1601000	BBL-1601000	.160	1.000	.040	.006 - .008	2.000	BB-1601000S	0
1/4" Shanks – D2								
BB-180350	BBL-180350	.180	.350	.045	.006 - .008	2.500	BB-180350S	0
BB-180500	BBL-180500	.180	.500	.045	.006 - .008	2.500	BB-180500S	0
BB-180600	BBL-180600	.180	.600	.045	.006 - .008	2.500	BB-180600S	0
BB-180750	BBL-180750	.180	.750	.045	.006 - .008	2.500	BB-180750S	0
BB-180900	BBL-180900	.180	.900	.045	.006 - .008	2.500	BB-180900S	0
BB-1801000	BBL-1801000	.180	1.000	.045	.006 - .008	2.500	BB-1801000S	0
BB-1801100	BBL-1801100	.180	1.100	.045	.006 - .008	2.500	BB-1801100S	0
BB-1801250	BBL-1801250 ♦	.180	1.250	.045	.006 - .008	2.500	BB-1801250S	0
BB-1801500	BBL-1801500	.180	1.500	.045	.006 - .008	2.500	BB-1801500S	0
BB-200400	BBL-200400	.200	.400	.050	.006 - .008	2.500	BB-200400S	0
BB-200500	BBL-200500	.200	.500	.050	.006 - .008	2.500	BB-200500S	0
BB-200600	BBL-200600	.200	.600	.050	.006 - .008	2.500	BB-200600S	0
BB-200700	BBL-200700	.200	.700	.050	.006 - .008	2.500	BB-200700S	0
BB-200800	BBL-200800	.200	.800	.050	.006 - .008	2.500	BB-200800S	0
BB-200900	-	.200	.900	.050	.006 - .008	2.500	BB-200900S	0
BB-2001000	BBL-2001000	.200	1.000	.050	.006 - .008	2.500	BB-2001000S	0
BB-2001100	BBL-2001100 ♦	.200	1.100	.050	.006 - .008	2.500	BB-2001100S	0
BB-2001200	BBL-2001200	.200	1.200	.050	.006 - .008	2.500	BB-2001200S	0
BB-2001300	BBL-2001300	.200	1.300	.050	.006 - .008	2.500	BB-2001300S	0

Tool Sets on Page 34

♦ WHILE SUPPLIES LAST - Discontinued

A

Tolerances:

Shank Diameter: $-.0001"-.0003"$
 Minimum Bore Diameter: $0-.005"$
 Maximum Bore Depth: $+.050"-.000"$
 Overall Length: $\pm .015"$
 Tool Radius:
 1/8" Shanks: $.003"-.006"$
 3/16"-1/2" Shanks: $.006"-.008"$
 BB-S: 0" Radius

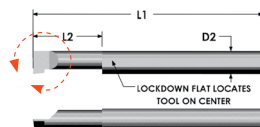
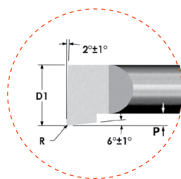
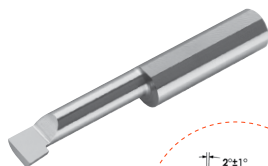

AITiN – Add “X” to the end of Catalog No.

TiN – Add “G” to the end of Catalog No.

Other sizes quoted upon request.

Other sizes quoted upon request.

BB	BBL	Minimum Bore Diameter (D1)	Maximum Bore Depth (L2)	Projection (P)	Tool Radius (R)	Overall Length (L1)	BB-S	Tool Radius (R)
RIGHT Hand Catalog No.	LEFT Hand Catalog No.	inch	inch	inch	inch	inch	Sharp Point Catalog No.	inch
5/16" Shanks – D2								
BB-230400	–	.230	.400	.058	.006 - .008	2.500	BB-230400S	0
BB-230500	–	.230	.500	.058	.006 - .008	2.500	BB-230500S	0
BB-230600	BBL-230600	.230	.600	.058	.006 - .008	2.500	BB-230600S	0
BB-230700	BBL-230700	.230	.700	.058	.006 - .008	2.500	BB-230700S	0
BB-230800	BBL-230800	.230	.800	.058	.006 - .008	2.500	BB-230800S	0
BB-230900	BBL-230900	.230	.900	.058	.006 - .008	2.500	BB-230900S	0
BB-2301000	BBL-2301000	.230	1.000	.058	.006 - .008	2.500	BB-2301000S	0
BB-2301100	BBL-2301100 ♦	.230	1.100	.058	.006 - .008	2.500	BB-2301150S	0
BB-2301150	BBL-2301150 ♦	.230	1.150	.058	.006 - .008	2.500	BB-2301150S	0
BB-2301200	BBL-2301200	.230	1.200	.058	.006 - .008	2.500	BB-2301200S	0
BB-2301250	–	.230	1.250	.058	.006 - .008	2.500	BB-2301250S	0
BB-2301400	BBL-2301400	.230	1.400	.058	.006 - .008	2.500	BB-2301400S	0
BB-2301500	BBL-2301500	.230	1.500	.058	.006 - .008	2.500	BB-2301500S	0
BB-2301600	BBL-2301600	.230	1.600	.058	.006 - .008	2.500	BB-2301600S	0
BB-290500	BBL-290500	.290	.500	.073	.006 - .008	2.500	BB-290500S	0
BB-290600	BBL-290600	.290	.600	.073	.006 - .008	2.500	BB-290600S	0
BB-290750	BBL-290750	.290	.750	.073	.006 - .008	2.500	BB-290750S	0
BB-290900	BBL-290900 ♦	.290	.900	.073	.006 - .008	2.500	BB-290900S	0
BB-2901000	BBL-2901000	.290	1.000	.073	.006 - .008	2.500	BB-2901000S	0
BB-2901100	BBL-2901100	.290	1.100	.073	.006 - .008	2.500	BB-2901100S	0
BB-2901250	BBL-2901250	.290	1.250	.073	.006 - .008	2.500	BB-2901250S	0
BB-2901350	BBL-2901350 ♦	.290	1.350	.073	.006 - .008	2.500	BB-2901350S	0
BB-2901500	BBL-2901500	.290	1.500	.073	.006 - .008	2.500	BB-2901500S	0
BB-2901600	–	.290	1.600	.073	.006 - .008	2.500	BB-2901600S	0
BB-2901750	BBL-2901600 ♦	.290	1.750	.073	.006 - .008	2.500	BB-2901750S	0
3/8" Shanks – D2								
BB-320500	BBL-320500 ♦	.320	.500	.080	.006 - .008	2.500	BB-320500S	0
BB-320600	BBL-320600	.320	.600	.080	.006 - .008	2.500	BB-320600S	0
BB-320750	BBL-320750	.320	.750	.080	.006 - .008	2.500	BB-320750S	0
BB-320900	BBL-320900 ♦	.320	.900	.080	.006 - .008	2.500	BB-320900S	0
BB-3201000	BBL-3201000	.320	1.000	.080	.006 - .008	2.500	BB-3201000S	0
BB-3201100	–	.320	1.100	.080	.006 - .008	2.500	BB-3201100S	0
BB-3201250	–	.320	1.250	.080	.006 - .008	2.500	BB-3201250S	0
BB-3201500	BBL-3201500	.320	1.500	.080	.006 - .008	2.500	BB-3201500S	0
BB-3201600	BBL-3201600 ♦	.320	1.600	.080	.006 - .008	2.500	BB-3201600S	0
BB-3201800	BBL-3201800 ♦	.320	1.800	.080	.006 - .008	2.500	BB-3201800S	0

Tool Sets on Page 34

A

Tolerances:

Shank Diameter: -.0001"-.0003"
 Minimum Bore Diameter: 0-.005"
 Maximum Bore Depth: +.050"-.000"
 Overall Length: ±.015"
 Tool Radius:
 1/8" Shanks: .003"-.006"
 3/16"-1/2" Shanks: .006"-.008"
 BB-S: 0" Radius

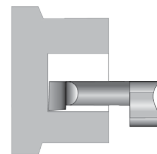
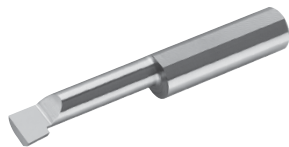

Page 274
for Coating
Info

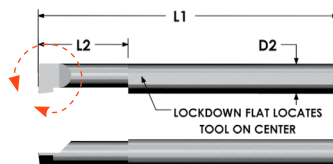
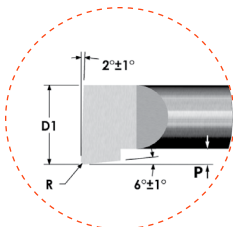

AITiN – Add “X” to the end of Catalog No.

TiN – Add “G” to the end of Catalog No.

Other sizes quoted upon request.

BB	BBL	Minimum Bore Diameter (D1)	Maximum Bore Depth (L2)	Projection (P)	Tool Radius (R)	Overall Length (L1)	BB-S	Tool Radius (R)
RIGHT Hand Catalog No.	LEFT Hand Catalog No.	inch	inch	inch	inch	inch	Sharp Point Catalog No.	inch
3/8" Shanks – D2								
BB-3202000	BBL-3202000	.320	2.000	.080	.006 -.008	4.000	BB-3202000S	0
BB-3202500	BBL-3202500 ♦	.320	2.500	.080	.006 -.008	4.000	BB-3302500S	0
BB-3203000	BBL-3203000	.320	3.000	.080	.006 -.008	4.000	BB-3303000S	0
BB-360500	–	.360	.500	.090	.006 -.008	2.500	BB-360500S	0
BB-360600	BBL-360600 ♦	.360	.600	.090	.006 -.008	2.500	BB-360600S	0
BB-360750	BBL-360750	.360	.750	.090	.006 -.008	2.500	BB-360750S	0
BB-360900	BBL-360900 ♦	.360	.900	.090	.006 -.008	2.500	BB-360900S	0
BB-3601000	BBL-3601000	.360	1.000	.090	.006 -.008	2.500	BB-3601000S	0
BB-3601150	BBL-3601150 ♦	.360	1.150	.090	.006 -.008	2.500	BB-3601150S	0
BB-3601250	BBL-3601250	.360	1.250	.090	.006 -.008	2.500	BB-3601250S	0
BB-3601500	BBL-3601500	.360	1.500	.090	.006 -.008	2.500	BB-3601500S	0
BB-3601600	BBL-3601600 ♦	.360	1.600	.090	.006 -.008	2.500	BB-3601600S	0
BB-3601800	–	.360	1.800	.090	.006 -.008	2.500	BB-3601800S	0
BB-3602000	BBL-3602000 ♦	.360	2.000	.090	.006 -.008	4.000	BB-3602000S	0
BB-3602500	BBL-3602500	.360	2.500	.090	.006 -.008	4.000	BB-3602500S	0
BB-3603000	BBL-3603000	.360	3.000	.090	.006 -.008	4.000	BB-3603000S	0
1/2" Shanks – D2								
BB-490750	–	.490	.750	.123	.006 -.008	3.000	BB-490750S	0
BB-4901000	–	.490	1.000	.123	.006 -.008	3.000	BB-4901000S	0
BB-4901250	–	.490	1.250	.123	.006 -.008	3.000	BB-4901250S	0
BB-4901500	BBL-4901500 ♦	.490	1.500	.123	.006 -.008	3.000	BB-4901500S	0
BB-4902000	BBL-4902000 ♦	.490	2.000	.123	.006 -.008	4.000	BB-4902000S	0
BB-4902500	–	.490	2.500	.123	.006 -.008	4.000	BB-4902500S	0
–	BBL-4902600 ♦	.490	2.600	.123	.006 -.008	4.000	BB-4902600S ♦	0
BB-4902750	BBL-4902750 ♦	.490	2.750	.123	.006 -.008	4.000	BB-4902750S	0
BB-4903000	–	.490	3.000	.123	.006 -.008	6.000	BB-4903000S	0
BB-4903500	BBL-4903500 ♦	.490	3.500	.123	.006 -.008	6.000	BB-4903500S	0
BB-4904000	–	.490	4.000	.123	.006 -.008	6.000	BB-4904000S	0
BB-4904500	BBL-4904500 ♦	.490	4.500	.123	.006 -.008	6.000	BB-4904500S	0

Tool Sets on Page 34

♦ WHILE SUPPLIES LAST - Discontinued

A

Tolerances:

Shank Diameter: $-.0001"/-.0003"$
Minimum Bore Diameter: $+.001"/-0"$
Maximum Bore Depth: $+.032"/-0"$
Overall Length: $\pm.015"$

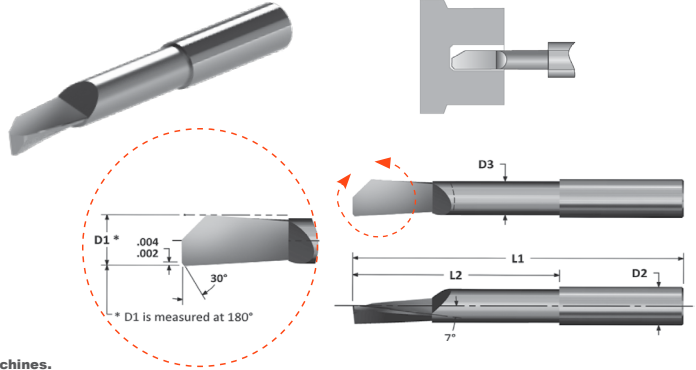

AlTiN – Add “X” to the end of Catalog No.

TiN – Add “G” to the end of Catalog No.

Other sizes quoted upon request.

Neck is centered to shank for use in jig bore machines.
The helical grind provides ideal top rake for better chip control.

HBB Catalog No.	Minimum Bore Diameter (D1)	Maximum Bore Depth (L2)	Overall Length (L1)	Neck Diameter (D3)
	inch	inch	inch	inch
1/8" Shanks – D2				
HBB-020062	.020	.062	1.500	.015
HBB-025062	.025	.062	1.500	.020
HBB-025125	.025	.125	1.500	.020
HBB-030125	.030	.125	1.500	.025
HBB-030187	.030	.187	1.500	.025
HBB-035125	.035	.125	1.500	.030
HBB-035187	.035	.187	1.500	.030
HBB-040187	.040	.187	1.500	.035
HBB-040250	.040	.250	1.500	.035
HBB-050312	.050	.312	1.500	.040
HBB-060375	.060	.375	1.500	.050
HBB-070437	.070	.437	1.500	.060
HBB-080500	.080	.500	1.500	.070
HBB-090500	.090	.500	1.500	.080
HBB-100562	.100	.562	1.500	.090
HBB-120625	.120	.625	1.500	.100
HBB-1201000	.120	1.000	1.500	.100
3/16" Shanks – D2				
HBB-135750	.135	.750	2.000	.110
HBB-1351000	.135	1.000	2.000	.110
HBB-1501000	.150	1.000	2.000	.130
HBB-1501250	.150	1.250	2.000	.130
HBB-1801000	.180	1.000	2.000	.160
HBB-1801250	.180	1.250	2.000	.160
HBB-1801500	.180	1.500	2.000	.160
1/4" Shanks – D2				
HBB-2101000	.210	1.000	2.500	.185
HBB-2101250	.210	1.250	2.500	.185
HBB-2101500	.210	1.500	2.500	.185
HBB-2401000	.240	1.000	2.500	.215
HBB-2401500	.240	1.500	2.500	.215
HBB-2401750	.240	1.750	2.500	.215



Tolerances:

Shank Diameter: $-.0001"/-0.0003"$
 Minimum Bore Diameter: $+.001"/-0"$
 Maximum Bore Depth: $+.032"/-0"$
 Overall Length: $\pm 0.015"$

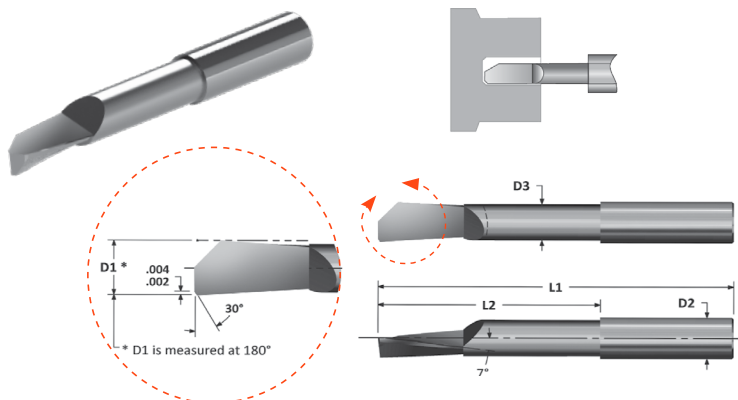

AlTiN – Add “X” to the end of Catalog No.

TiN – Add “G” to the end of Catalog No.

Other sizes quoted upon request.

Neck is centered to shank for use in jig bore machines.
 The helical grind provides ideal top rake for better chip control.

HBB Catalog No.	Minimum Bore Diameter (D1)	Maximum Bore Depth (L2)	Overall Length (L1)	Neck Diameter (D3)
	inch	inch	inch	inch
5/16" Shanks – D2				
HBB-3001000	.300	1.000	2.500	.250
HBB-3001500	.300	1.500	2.500	.250
HBB-3001750	.300	1.750	2.500	.250
3/8" Shanks – D2				
HBB-3601000	.360	1.000	2.500	.250
HBB-3601500	.360	1.500	2.500	.250
HBB-3601750 ♦	.360	1.750	2.500	.250
HBB-3602000	.360	2.000	4.000	.320
HBB-3602250 ♦	.360	2.250	4.000	.320
HBB-3602500	.360	2.500	4.000	.320
1/2" Shanks – D2				
HBB-4802500 ♦	.480	2.500	4.000	.440
HBB-4803000 ♦	.480	3.000	4.000	.440

♦ WHILE SUPPLIES LAST - Discontinued



For current pricing and availability please visit our website at www.micro100.com

A

Tolerances:

Shank Diameter: $-.0001"-.0003"$
 Minimum Bore Diameter: $0"-.005"$
 Maximum Bore Depth: $+.050"0"$
 Overall Length: $\pm 0.015"$

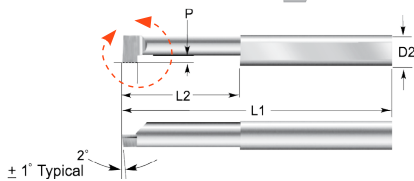
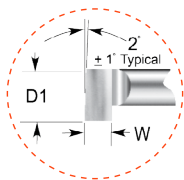
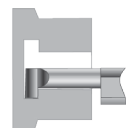

AlTiN – Add “X” to the end of Catalog No.

TiN – Add “G” to the end of Catalog No.

LEFT HAND TOOLS AVAILABLE as SPECIALS.

Other sizes quoted upon request.

RR	RRL	Groove Width (W)	Projection (P)	Minimum Bore Diameter (D1)	Maximum Bore Depth (L2)	Overall Length (L1)
RIGHT Hand Catalog No.	LEFT Hand Catalog No.	inch	inch	inch	inch	inch
1/4" Shanks – D2						
RR-017-4	RRL-017-4	.017/.018	.050	.250	.250	2.500
RR-017-6	–	.017/.018	.050	.250	.375	2.500
RR-017-8	RRL-017-8	.017/.018	.050	.250	.500	2.500
RR-017-10	–	.017/.018	.050	.250	.625	2.500
RR-025-4	RRL-025-4	.025/.026	.050	.250	.250	2.500
RR-025-6	RRL-025-6 ♦	.025/.026	.050	.250	.375	2.500
RR-025-8	RRL-025-8	.025/.026	.050	.250	.500	2.500
RR-025-10	–	.025/.026	.050	.250	.625	2.500
RR-030-4	RRL-030-4	.030/.031	.050	.250	.250	2.500
RR-030-6	RRL-030-6	.030/.031	.050	.250	.375	2.500
RR-030-8	RRL-030-8	.030/.031	.050	.250	.500	2.500
RR-030-10	RRL-030-10	.030/.031	.050	.250	.625	2.500
5/16" Shanks – D2						
RR-033-4	RRL-033-4	.033/.034	.100	.312	.250	2.500
RR-033-6	RRL-033-6 ♦	.033/.034	.100	.312	.375	2.500
RR-033-8	RRL-033-8 ♦	.033/.034	.100	.312	.500	2.500
RR-033-12	RRL-033-12	.033/.034	.100	.312	.750	2.500
RR-038-4	RRL-038-4 ♦	.038/.039	.100	.312	.250	2.500
RR-038-6	RRL-038-6	.038/.039	.100	.312	.375	2.500
RR-038-8	RRL-038-8	.038/.039	.100	.312	.500	2.500
RR-038-12	RRL-0380-12	.038/.039	.100	.312	.750	2.500
3/8" Shanks – D2						
RR-039-4	RRL-039-4	.039/.041	.100	.375	.250	2.500
RR-039-6	–	.039/.041	.100	.375	.375	2.500
RR-039-8	RRL-039-8	.039/.041	.100	.375	.500	2.500
RR-039-12	RRL-039-12	.039/.041	.100	.375	.750	2.500
RR-039-16	–	.039/.041	.100	.375	1.000	2.500
RR-039-20	–	.039/.041	.100	.375	1.250	2.500
RR-046-4	RRL-046-4	.046/.048	.100	.375	.250	2.500
RR-046-6	RRL-046-6	.046/.048	.100	.375	.375	2.500
RR-046-8	–	.046/.048	.100	.375	.500	2.500
RR-046-12	RRL-046-12	.046/.048	.100	.375	.750	2.500
RR-046-16	RRL-046-16	.046/.048	.100	.375	1.000	2.500
RR-046-20	RRL-046-20	.046/.048	.100	.375	1.250	2.500

♦ WHILE SUPPLIES LAST - Discontinued

Tool Sets on Page 34

A

Tolerances:

Shank Diameter: $-.0001"-.0003"$
 Minimum Bore Diameter: $0"-.005"$
 Maximum Bore Depth: $+.050"-0"$
 Overall Length: $\pm .015"$

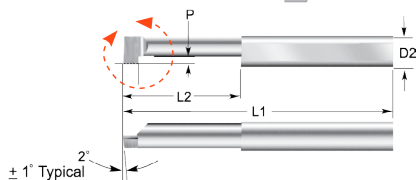
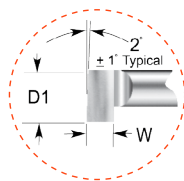
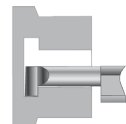
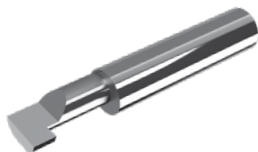

AITiN – Add “X” to the end of Catalog No.

TiN – Add “G” to the end of Catalog No.

LEFT HAND TOOLS AVAILABLE as SPECIALS.

Other sizes quoted upon request.

RR	RRL	Groove Width (W)	Projection (P)	Minimum Bore Diameter (D1)	Maximum Bore Depth (L2)	Overall Length (L1)
RIGHT Hand Catalog No.	LEFT Hand Catalog No.	inch	inch	inch	inch	inch
3/8" Shanks – D2						
RR-055-4	RRL-055-4 ♦	.055/.057	.100	.375	.250	2.500
RR-055-6	–	.055/.057	.100	.375	.375	2.500
RR-055-8	RRL-055-8 ♦	.055/.057	.100	.375	.500	2.500
RR-055-12	RRL-055-12	.055/.057	.100	.375	.750	2.500
RR-055-16	–	.055/.057	.100	.375	1.000	2.500
RR-055-20	–	.055/.057	.100	.375	1.250	2.500
RR-062-4	RRL-062-4 ♦	.062/.064	.100	.375	.250	2.500
RR-062-6	RRL-062-6 ♦	.062/.064	.100	.375	.375	2.500
RR-062-8	RRL-062-8	.062/.064	.100	.375	.500	2.500
RR-062-12	–	.062/.064	.100	.375	.750	2.500
RR-062-16	RRL-062-16	.062/.064	.100	.375	1.000	2.500
RR-062-20	RRL-062-20	.062/.064	.100	.375	1.250	2.500
RR-069-6	–	.069/.071	.100	.375	.375	2.500
RR-069-8	RRL-069-8	.069/.071	.100	.375	.500	2.500
RR-069-12	RRL-069-12 ♦	.069/.071	.100	.375	.750	2.500
RR-069-16	RRL-069-16	.069/.071	.100	.375	1.000	2.500
RR-069-20	RRL-069-20 ♦	.069/.071	.100	.375	1.250	2.500
RR-087-4	–	.087/.089	.100	.375	.250	2.500
RR-087-6	RRL-087-6 ♦	.087/.089	.100	.375	.375	2.500
RR-087-8	RRL-087-8	.087/.089	.100	.375	.500	2.500
RR-087-12	RRL-087-12	.087/.089	.100	.375	.750	2.500
RR-087-16	RRL-087-16	.087/.089	.100	.375	1.000	2.500
RR-087-20	RRL-087-20	.087/.089	.100	.375	1.250	2.500
1/2" Shanks – D2						
RR-093-8	–	.093/.095	.150	.500	.500	3.000
RR-093-12	RRL-093-12	.093/.095	.150	.500	.750	3.000
RR-093-16	RRL-093-16	.093/.095	.150	.500	1.000	3.000
RR-093-20	–	.093/.095	.150	.500	1.250	3.000
RR-093-24	RRL-093-24	.093/.095	.150	.500	1.500	3.000
RR-125-8	RRL-125-8	.125/.127	.150	.500	.500	3.000
RR-125-12	RRL-125-12	.125/.127	.150	.500	.750	3.000
RR-125-16	RRL-125-16	.125/.127	.150	.500	1.000	3.000
RR-125-20	–	.125/.127	.150	.500	1.250	3.000
RR-125-24	RRL-125-24	.125/.127	.150	.500	1.500	3.000

Tool Sets on Page 34

♦ WHILE SUPPLIES LAST - Discontinued

A

Tolerances:
Shank Diameter: $-.0001"-.0003"$
Minimum Bore Diameter: $0"-.005"$
Maximum Bore Depth: $+.050"-0"$
Overall Length: $\pm .015"$

**Page 274
for Coating
Info**

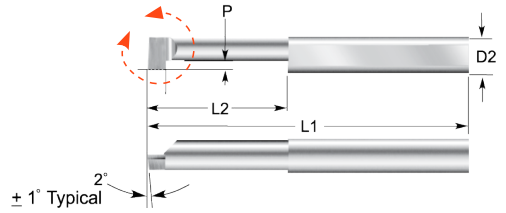
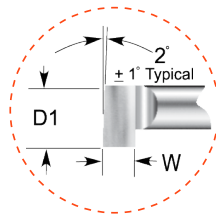
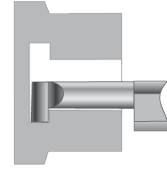
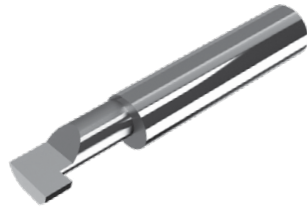

AITiN – Add “X” to the end of Catalog No.

TiN – Add “G” to the end of Catalog No.

LEFT HAND TOOLS AVAILABLE as SPECIALS.

Other sizes quoted upon request.

RR	RRL	Groove Width (W)	Projection (P)	Minimum Bore Diameter (D1)	Maximum Bore Depth (L2)	Overall Length (L1)
Catalog No.	Catalog No.	inch	inch	inch	inch	inch
1/2" Shanks – D2						
–	RRL-156-8 ♦	.156/.158	.150	.500	.500	3.000
RR-156-12	–	.156/.158	.150	.500	.750	3.000
RR-156-16	–	.156/.158	.150	.500	1.000	3.000
RR-156-20	–	.156/.158	.150	.500	1.250	3.000
RR-156-24	RRL-156-24 ♦	.156/.158	.150	.500	1.500	3.000
–	RRL-187-8 ♦	.187/.189	.150	.500	.500	3.000
RR-187-12	–	.187/.189	.150	.500	.750	3.000
RR-187-16	RRL-187-16 ♦	.187/.189	.150	.500	1.000	3.000
RR-187-20	RRL-187-20 ♦	.187/.189	.150	.500	1.250	3.000
RR-187-24	RRL-187-24 ♦	.187/.189	.150	.500	1.500	3.000
–	RRL-250-8 ♦	.250/.252	.150	.500	.500	3.000
RR-250-12	RRL-250-12 ♦	.250/.252	.150	.500	.750	3.000
RR-250-16	RRL-250-16 ♦	.250/.252	.150	.500	1.000	3.000
RR-250-20	RRL-250-20 ♦	.250/.252	.150	.500	1.250	3.000
RR-250-24	RRL-250-24 ♦	.250/.252	.150	.500	1.500	3.000

♦ WHILE SUPPLIES LAST - Discontinued

For current pricing and availability please visit our website at www.micro100.com



Tolerances:

Shank Diameter: $-.0001''-.0003''$
 Minimum Bore Diameter: $0''-.005''$
 Maximum Bore Depth: $+.050''-0''$
 Overall Length: $\pm .015''$

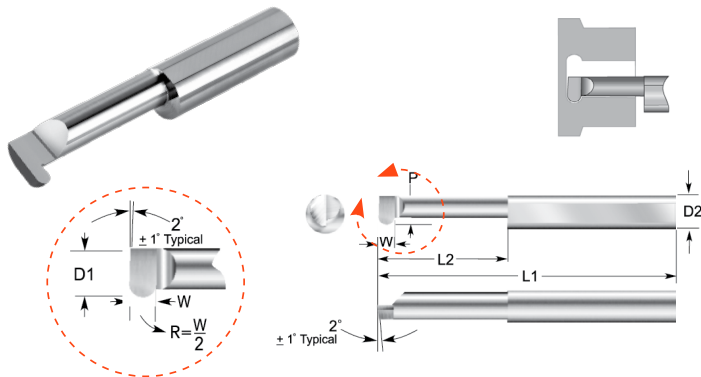

AITiN – Add “X” to the end of Catalog No.

TiN – Add “G” to the end of Catalog No.

LEFT HAND TOOLS AVAILABLE as SPECIALS.

Other sizes quoted upon request.

FR Catalog No.	Groove Width (W)	Projection (P)	Minimum Bore Diameter (D1)	Maximum Bore Depth (L2)	Overall Length (L1)
	inch	inch	inch	inch	inch
1/4" Shanks – D2					
FR-017-4	.017/.019	.050	.250	.250	2.500
FR-017-6	.017/.019	.050	.250	.375	2.500
FR-017-8	.017/.019	.050	.250	.500	2.500
FR-017-10	.017/.019	.050	.250	.625	2.500
FR-025-4	.025/.027	.050	.250	.250	2.500
FR-025-6	.025/.027	.050	.250	.375	2.500
FR-025-8	.025/.027	.050	.250	.500	2.500
FR-025-10	.025/.027	.050	.250	.625	2.500
FR-030-4	.030/.032	.050	.250	.250	2.500
FR-030-6	.030/.032	.050	.250	.375	2.500
FR-030-8	.030/.032	.050	.250	.500	2.500
FR-030-10	.030/.032	.050	.250	.625	2.500
5/16" Shanks – D2					
FR-033-4	.033/.035	.100	.312	.250	2.500
FR-033-6	.033/.035	.100	.312	.375	2.500
FR-033-8	.033/.035	.100	.312	.500	2.500
FR-033-10	.033/.035	.100	.312	.625	2.500
FR-038-4	.038/.040	.100	.312	.250	2.500
FR-038-6	.038/.040	.100	.312	.375	2.500
FR-038-8	.038/.040	.100	.312	.500	2.500
FR-038-10	.038/.040	.100	.312	.625	2.500
3/8" Shanks – D2					
FR-039-4	.039/.041	.100	.375	.250	2.500
FR-039-6	.039/.041	.100	.375	.375	2.500
FR-039-8	.039/.041	.100	.375	.500	2.500
FR-039-12	.039/.041	.100	.375	.750	2.500
FR-039-16	.039/.041	.100	.375	1.000	2.500
FR-039-20	.039/.041	.100	.375	1.250	2.500
FR-046-4	.046/.048	.100	.375	.250	2.500
FR-046-6	.046/.048	.100	.375	.375	2.500
FR-046-8	.046/.048	.100	.375	.500	2.500
FR-046-12	.046/.048	.100	.375	.750	2.500
FR-046-16	.046/.048	.100	.375	1.000	2.500
FR-046-20	.046/.048	.100	.375	1.250	2.500

A

Tolerances:
Shank Diameter: $-.0001"$ -. $.0003"$
Minimum Bore Diameter: $0"$ -. $.005"$
Maximum Bore Depth: $+.050"$ - $0"$
Overall Length: $\pm .015"$

**Page 274
for Coating
Info**

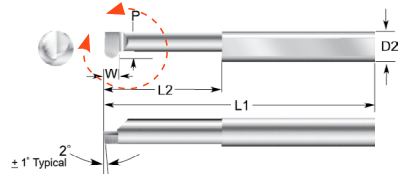
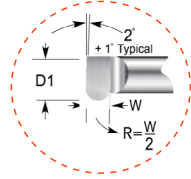
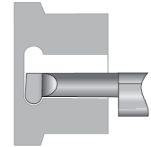

AITiN – Add “X” to the end of Catalog No.

TiN – Add “G” to the end of Catalog No.

LEFT HAND TOOLS AVAILABLE as SPECIALS.

Other sizes quoted upon request.

FR Catalog No.	Groove Width (W) inch	Projection (P) inch	Minimum Bore Diameter (D1) inch	Maximum Bore Depth (L2) inch	Overall Length (L1) inch
3/8" Shanks – D2					
FR-055-4	.055/.057	.100	.375	.250	2.500
FR-055-6	.055/.057	.100	.375	.375	2.500
FR-055-8	.055/.057	.100	.375	.500	2.500
FR-055-12	.055/.057	.100	.375	.750	2.500
FR-055-16	.055/.057	.100	.375	1.000	2.500
FR-055-20	.055/.057	.100	.375	1.250	2.500
FR-062-4	.062/.064	.100	.375	.250	2.500
FR-062-6	.062/.064	.100	.375	.375	2.500
FR-062-8	.062/.064	.100	.375	.500	2.500
FR-062-12	.062/.064	.100	.375	.750	2.500
FR-062-16	.062/.064	.100	.375	1.000	2.500
FR-062-20	.062/.064	.100	.375	1.250	2.500
FR-069-4	.069/.071	.100	.375	.250	2.500
FR-069-6	.069/.071	.100	.375	.375	2.500
FR-069-8	.069/.071	.100	.375	.500	2.500
FR-069-12	.069/.071	.100	.375	.750	2.500
FR-069-16	.069/.071	.100	.375	1.000	2.500
FR-069-20	.069/.071	.100	.375	1.250	2.500
FR-087-4	.087/.089	.100	.375	.250	2.500
FR-087-6	.087/.089	.100	.375	.375	2.500
FR-087-8	.087/.089	.100	.375	.500	2.500
FR-087-12	.087/.089	.100	.375	.750	2.500
FR-087-16	.087/.089	.100	.375	1.000	2.500
FR-087-20	.087/.089	.100	.375	1.250	2.500
1/2" Shanks – D2					
FR-093-8	.093/.095	.150	.500	.500	3.000
FR-093-12	.093/.095	.150	.500	.750	3.000
FR-093-16	.093/.095	.150	.500	1.000	3.000
FR-093-20	.093/.095	.150	.500	1.250	3.000
FR-093-24	.093/.095	.150	.500	1.500	3.000
FR-125-8	.125/.127	.150	.500	.500	3.000
FR-125-12	.125/.127	.150	.500	.750	3.000
FR-125-16	.125/.127	.150	.500	1.000	3.000
FR-125-20	.125/.127	.150	.500	1.250	3.000
FR-125-24	.125/.127	.150	.500	1.500	3.000

A

Tolerances:

Shank Diameter: $-.0001"-.0003"$
 Minimum Bore Diameter: $0"-.005"$
 Maximum Bore Depth: $+.050"-0"$
 Overall Length: $\pm .015"$

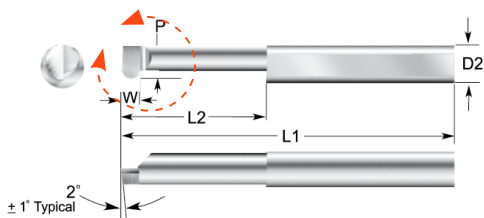
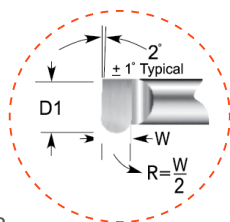
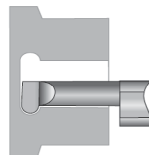

AlTiN – Add “X” to the end of Catalog No.

TiN – Add “G” to the end of Catalog No.

LEFT HAND TOOLS AVAILABLE as SPECIALS.

Other sizes quoted upon request.

FR Catalog No.	Groove Width (W)	Projection (P)	Minimum Bore Diameter (D1)	Maximum Bore Depth (L2)	Overall Length (L1)
	inch	inch	inch	inch	inch
1/2" Shanks – D2					
FR-187-8	.187/.189	.150	.500	.500	3.000
FR-187-12	.187/.189	.150	.500	.750	3.000
FR-187-16	.187/.189	.150	.500	1.000	3.000
FR-187-20	.187/.189	.150	.500	1.250	3.000
FR-187-24	.187/.189	.150	.500	1.500	3.000

Page 274
for Coating
Info

For current pricing and availability please visit our website at www.micro100.com

A

Tolerances:

Shank Diameter: $-.0001"$ -. $.0003"$
Minimum Bore Diameter: $0"$ -. $.005"$
Maximum Bore Depth: $+.050"$ - $0"$
Overall Length: $\pm .015"$

Page 274
for Coating
Info

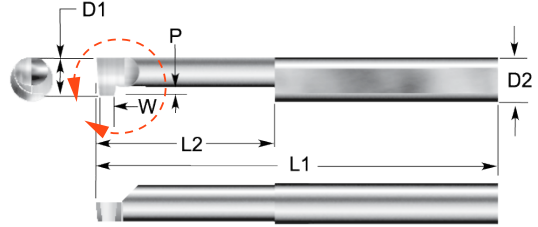
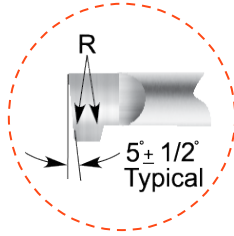
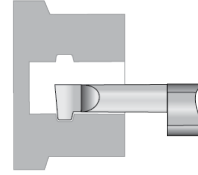

AITiN – Add "X" to the end of Catalog No.

TiN – Add "G" to the end of Catalog No.

LEFT HAND TOOLS AVAILABLE as SPECIALS.

Other sizes quoted upon request.

OR Catalog No.	Groove Width (W)	Projection (P)	Tool Radius (R)	Minimum Hole Diameter (D1)	Maximum Hole Depth (L2)	Overall Length (L1)
	inch	inch	inch	inch	inch	inch
1/4" Shanks – D2						
OR-096-8	.096/.098	.100	.010/.020	.250	.500	2.500
OR-141-9	.141/.143	.100	.035/.045	.250	.562	2.500
OR-144-10	.144/.146	.100	.035/.045	.250	.625	2.500
3/8" Shanks – D2						
OR-174-12	.174/.176	.115	.010/.020	.375	.750	2.500
OR-208-13	.208/.210	.115	.035/.045	.375	.812	2.500
OR-241-15	.241/.243	.115	.035/.045	.375	.938	2.500

For current pricing and availability please visit our website at www.micro100.com



Tolerances:
 Shank Diameter: $-.0001"-.0003"$
 Projection: $+.015"-.000"$
 Overall Length: $\pm 0.015"$

Page 274
 for Coating
 Info

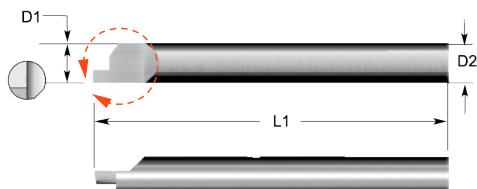
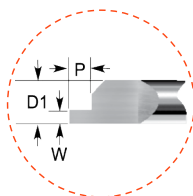
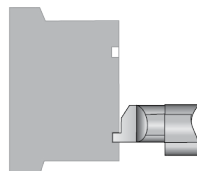
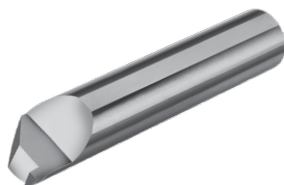

AITiN – Add “X” to the end of Catalog No.

TiN – Add “G” to the end of Catalog No.

LEFT HAND TOOLS AVAILABLE as SPECIALS.

Other sizes quoted upon request.

FG Catalog No.	Groove Width (W)	Projection (P)	Minimum Groove Diameter (D1)	Overall Length (L1)
	inch	inch	inch	inch
1/4" Shanks – D2				
FG-250-020	.020/.022	.050	.260	2.500
FG-250-030	.030/.032	.050	.260	2.500
FG-250-040	.040/.042	.050	.260	2.500
FG-250-050	.050/.052	.050	.260	2.500
5/16" Shanks – D2				
FG-312-030	.030/.032	.050	.320	2.500
FG-312-040	.040/.042	.050	.320	2.500
FG-312-050	.050/.052	.075	.320	2.500
FG-312-062	.062/.064	.075	.320	2.500
3/8" Shanks – D2				
FG-375-030	.030/.032	.050	.385	2.500
FG-375-062	.062/.064	.075	.385	2.500
FG-375-093	.093/.095	.100	.385	2.500
FG-375-125	.125/.127	.100	.385	2.500
1/2" Shanks – D2				
FG-500-062	.062/.064	.075	.510	3.000
FG-500-093	.093/.095	.100	.510	3.000
FG-500-125	.125/.127	.100	.510	3.000
FG-500-156	.156/.158	.100	.510	3.000
5/8" Shanks – D2				
FG-625-062	.062/.064	.075	.635	3.500
FG-625-093	.093/.095	.100	.635	3.500
FG-625-156	.156/.158	.100	.635	3.500
FG-625-187	.187/.189	.150	.635	3.500
3/4" Shanks – D2				
FG-750-093 ♦	.093/.095	.100	.760	4.000
FG-750-125	.125/.127	.100	.760	4.000
FG-750-156 ♦	.156/.158	.100	.760	4.000
FG-750-187	.187/.189	.150	.760	4.000
FG-750-250	.250/.252	.250	.760	4.000

♦ WHILE SUPPLIES LAST - Discontinued

A

Tolerances:

Shank Diameter: $-.0001"-.0003"$
 Minimum Bore Diameter: $+.000"-.005"$
 Maximum Bore Depth: $+.050"-.000"$
 Overall Length: $\pm.015"$

Page 274
for Coating
Info

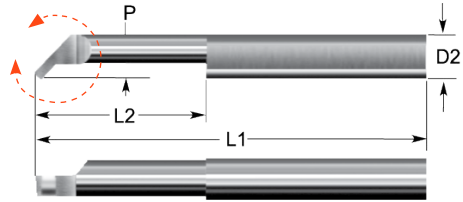
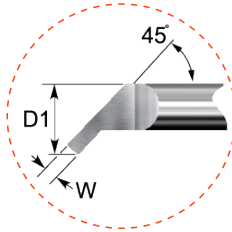
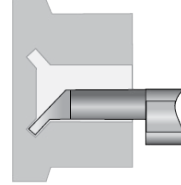

AITIN – Add "X" to the end of Catalog No.

Other sizes quoted upon request.

UC Catalog No.	Groove Width (W)	Projection (P)	Minimum Bore Diameter (D1)	Maximum Bore Depth (L2)	Overall Length (L1)
	inch	inch	inch	inch	inch
1/4" Shanks – D2					
UC-25030-8	.030/.032	.060	.240	.500	2.500
5/16" Shanks – D2					
UC-31050-8	.050/.052	.083	.302	.500	2.500
UC-31062-16	.062/.064	.083	.302	1.000	2.500
UC-31062-20	.062/.064	.083	.302	1.250	2.500
3/8" Shanks – D2					
UC-37062-16	.062/.064	.095	.365	1.000	2.500
UC-37062-20 ♦	.062/.064	.095	.365	1.250	2.500
UC-37093-16	.093/.095	.095	.365	1.000	2.500
UC-37125-16	.125/.127	.095	.365	1.000	2.500
UC-37125-20 ♦	.125/.127	.095	.365	1.250	2.500
1/2" Shanks – D2					
UC-50062-16	.062/.064	.150	.490	1.000	3.000
UC-50062-24	.062/.064	.150	.490	1.500	3.000
UC-50093-24	.093/.095	.150	.490	1.500	3.000
UC-50125-16	.125/.127	.150	.490	1.000	3.000
UC-50125-24	.125/.127	.150	.490	1.500	3.000

♦ WHILE SUPPLIES LAST - Discontinued

For current pricing and availability please visit our website at www.micro100.com

Tolerances:

Shank Diameter: $-.0001"-.0003"$
 Minimum Bore Diameter: $+.000"-.005"$
 Maximum Bore Depth: $+.050"-.000"$
 Overall Length: $\pm.015"$

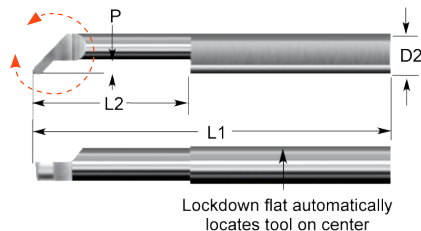
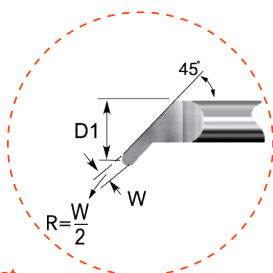
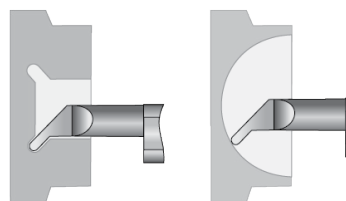
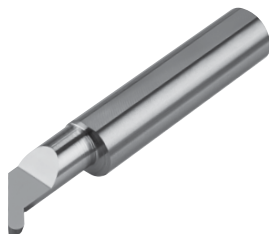

AITiN – Add “X” to the end of Catalog No.

Other sizes quoted upon request.

UP Catalog No.	Groove Width (W) inch	Projection (P) inch	Minimum Bore Diameter (D1) inch	Maximum Bore Depth (L2) inch	Overall Length (L1) inch
1/4" Shanks – D2					
UP-25030-8	.030/.032	.060	.240	.500	2.500
UP-25030-16	.030/.032	.060	.240	1.000	2.500
5/16" Shanks – D2					
UP-31050-8	.050/.052	.083	.302	.500	2.500
UP-31050-16	.050/.052	.083	.302	1.000	2.500
UP-31062-16	.062/.064	.083	.302	1.000	2.500
UP-31062-20	.062/.064	.083	.302	1.250	2.500
3/8" Shanks – D2					
UP-37062-16	.062/.064	.095	.365	1.000	2.500
UP-37062-20	.062/.064	.095	.365	1.250	2.500
UP-37093-16	.093/.095	.095	.365	1.000	2.500
UP-37125-16	.125/.127	.095	.365	1.000	2.500
UP-37125-20	.125/.127	.095	.365	1.250	2.500
1/2" Shanks – D2					
UP-50062-16	.062/.064	.125	.490	1.000	3.000
UP-50062-24	.062/.064	.125	.490	1.500	3.000
UP-50093-16	.093/.095	.125	.490	1.000	3.000
UP-50093-24	.093/.095	.125	.490	1.500	3.000
UP-50125-16	.125/.127	.125	.490	1.000	3.000
UP-50125-24	.125/.127	.125	.490	1.500	3.000

For current pricing and availability please visit our website at www.micro100.com

A

Tolerances:
Shank Diameter: $-.0001"-.0003"$
Minimum Bore Diameter: $0"-.005"$
Maximum Bore Depth: $+.050"-0"$
Overall Length: $\pm.015"$
Tool Radius: $.002" \pm .001"$

Page 274
for Coating
Info

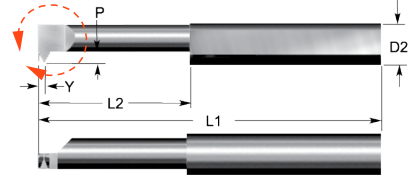
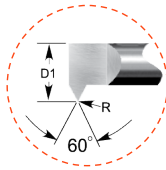
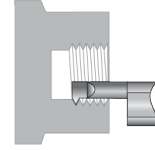

Tool Radius:
 $.002"(.05mm) \pm .001"(\pm .03mm)$

AITiN – Add "X" to the end of Catalog No.

Other sizes quoted upon request.

IT	ITL	UN Thread Range (T.P.I.)	Minimum Bore Diameter (D1)	Projection (P)	Maximum Bore Depth (L2)	Offset Point (Y)	Overall Length (L1)
RIGHT Hand Catalog No.	LEFT Hand Catalog No.	inch	inch	inch	inch	inch	inch
1/8" Shanks – D2							
IT-040075	ITL-040075 ♦	56 TO 76	.040	.015	.075	.009	1.500
IT-040100	-	56 TO 76	.040	.015	.100	.009	1.500
IT-040150	ITL-040150	56 TO 76	.040	.015	.150	.009	1.500
IT-050100	-	48 TO 76	.050	.020	.100	.012	1.500
IT-050150	-	48 TO 76	.050	.020	.150	.012	1.500
IT-050200	ITL-050200	48 TO 76	.050	.020	.200	.012	1.500
IT-060200	ITL-060200	48 TO 76	.060	.020	.200	.012	1.500
IT-060250	ITL-060250	48 TO 76	.060	.020	.250	.012	1.500
IT-060300	ITL-060300	48 TO 76	.060	.020	.300	.012	1.500
IT-080250	ITL-080250	40 TO 76	.080	.020	.250	.012	1.500
IT-080350	ITL-080350	40 TO 76	.080	.020	.350	.012	1.500
IT-080500	ITL-080500	40 TO 76	.080	.020	.500	.012	1.500
IT-100250	ITL-100250	32 TO 76	.100	.025	.250	.014	1.500
IT-100350	ITL-100350	32 TO 76	.100	.025	.350	.014	1.500
IT-100500	ITL-100500	32 TO 76	.100	.025	.500	.014	1.500
IT-100600	ITL-100600	32 TO 76	.100	.025	.600	.014	1.500
3/16" Shanks – D2							
IT-120250	ITL-120250	32 TO 56	.120	.030	.250	.017	2.000
IT-120400	ITL-120400	32 TO 56	.120	.030	.400	.017	2.000
IT-120500	ITL-120500	32 TO 56	.120	.030	.500	.017	2.000
IT-120600	ITL-120600	32 TO 56	.120	.030	.600	.017	2.000
IT-120750	ITL-120750	32 TO 56	.120	.030	.750	.017	2.000
IT-140250	ITL-140250	28 TO 56	.140	.035	.250	.020	2.000
IT-140400	ITL-140400	28 TO 56	.140	.035	.400	.020	2.000
IT-140500	ITL-140500	28 TO 56	.140	.035	.500	.020	2.000
IT-140750	ITL-140750	28 TO 56	.140	.035	.750	.020	2.000
IT-160250	ITL-160250	24 TO 56	.160	.040	.250	.023	2.000
IT-160400	ITL-160400	24 TO 56	.160	.040	.400	.023	2.000
IT-160500	ITL-160500	24 TO 56	.160	.040	.500	.023	2.000
IT-160750	ITL-160750	24 TO 56	.160	.040	.750	.023	2.000
IT-1601000	-	24 TO 56	.160	.040	1.000	.023	2.000

♦ WHILE SUPPLIES LAST - Discontinued



Tolerances:

Shank Diameter: $-.0001''-.0003''$
 Minimum Bore Diameter: $0''-.005''$
 Maximum Bore Depth: $+.050''-0''$
 Overall Length: $\pm 0.015''$
 Tool Radius: $.002''\pm .001''$

Page 274
for Coating
Info

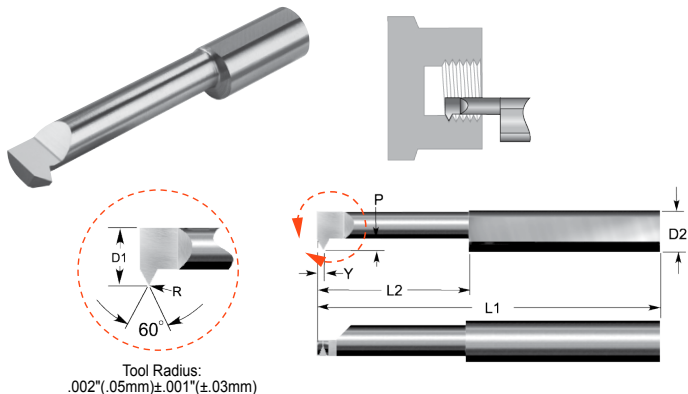

Tool Radius:
.002"(.05mm) \pm .001"(\pm .03mm)

AITin – Add “X” to the end of Catalog No.

Other sizes quoted upon request.

IT RIGHT Hand Catalog No.	ITL LEFT Hand Catalog No.	UN Thread Range (T.P.I.)	Minimum Bore Diameter (D1)	Projection (P)	Maximum Bore Depth (L2)	Offset Point (Y)	Overall Length (L1)
		inch	inch	inch	inch	inch	inch
1/4" Shanks – D2							
IT-180350	ITL-180350	24 TO 56	.180	.040	.350	.023	2.500
IT-180500	ITL-180500	24 TO 56	.180	.040	.500	.023	2.500
IT-180750	ITL-180750	24 TO 56	.180	.040	.750	.023	2.500
IT-1801000	ITL-1801000	24 TO 56	.180	.040	1.000	.023	2.500
IT-200400	ITL-200400	24 TO 40	.200	.045	.400	.026	2.500
IT-200600	ITL-200600	24 TO 40	.200	.045	.600	.026	2.500
IT-200750	ITL-200750	24 TO 40	.200	.045	.750	.026	2.500
IT-2001000	ITL-2001000	24 TO 40	.200	.045	1.000	.026	2.500
5/16" Shanks – D2							
IT-230400	ITL-230400	20 TO 40	.230	.055	.400	.032	2.500
IT-230600	ITL-230600	20 TO 40	.230	.055	.600	.032	2.500
IT-230750	ITL-230750	20 TO 40	.230	.055	.750	.032	2.500
IT-2301000	ITL-2301000	20 TO 40	.230	.055	1.000	.032	2.500
IT-2301500	-	20 TO 40	.230	.055	1.500	.032	2.500
IT-290500	ITL-290500	14 TO 40	.290	.070	.500	.040	2.500
IT-290750	ITL-290750	14 TO 40	.290	.070	.750	.040	2.500
IT-2901000	ITL-2901000	14 TO 40	.290	.070	1.000	.040	2.500
IT-2901250	ITL-2901250	14 TO 40	.290	.070	1.250	.040	2.500
IT-2901750	-	14 TO 40	.290	.070	1.750	.040	2.500
3/8" Shanks – D2							
IT-320500	ITL-320500	10 TO 32	.320	.075	.500	.043	2.500
IT-320750	ITL-320750	10 TO 32	.320	.075	.750	.043	2.500
IT-3201000	ITL-3201000	10 TO 32	.320	.075	1.000	.043	2.500
IT-3201250	ITL-3201250	10 TO 32	.320	.075	1.250	.043	2.500
IT-3201800	-	10 TO 32	.320	.075	1.800	.043	2.500
IT-360500	ITL-360500	10 TO 32	.360	.085	.500	.049	2.500
IT-360750	ITL-360750	10 TO 32	.360	.085	.750	.049	2.500
IT-3601000	ITL-3601000	10 TO 32	.360	.085	1.000	.049	2.500
IT-3601250	ITL-3601250	10 TO 32	.360	.085	1.250	.049	2.500
IT-3601800	ITL-3601800	10 TO 32	.360	.085	1.800	.049	2.500
1/2" Shanks – D2							
IT-490750	ITL-490750	6 TO 24	.490	.120	.750	.069	3.000
IT-4901500	ITL-4901500	6 TO 24	.490	.120	1.500	.069	3.000
IT-4902000	ITL-4902000	6 TO 24	.490	.120	2.000	.069	3.000

A

Tolerances:

Shank Diameter: $-.0001"$ -. $0003"$
Minimum Bore Diameter: $+.000"$ -. $005"$
Maximum Bore Depth: $+.050"$ -. $000"$
"W" Flat: $\pm.001"$
Overall Length: $\pm.015"$

**Page 274
for Coating
Info**

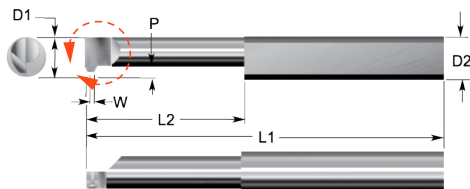
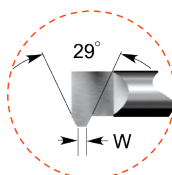
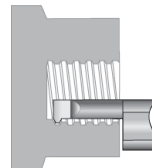
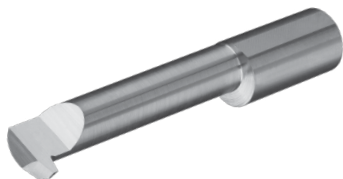

AITiN – Add "X" to the end of Catalog No.

SAT Catalog No.	Minimum Bore Diameter (D1)	Projection (P)	Maximum Bore Depth (L2)	Flat (W)	Threads Per Inch (T.P.I.)	Overall Length (L1)
	inch	inch	inch	inch	inch	inch
1/4" Shanks – D2						
SAT-400-16	.200	.045	.400	.024	16	2.500
SAT-600-16	.200	.045	.600	.024	16	2.500
SAT-750-16	.200	.045	.750	.024	16	2.500
SAT-1000-16	.200	.045	1.000	.024	16	2.500
5/16" Shanks – D2						
SAT-500-14	.235	.070	.500	.028	14	2.500
SAT-750-14	.235	.070	.750	.028	14	2.500
SAT-1000-14	.235	.070	1.000	.028	14	2.500
SAT-1750-14	.235	.070	1.750	.028	14	2.500
3/8" Shanks – D2						
SAT-500-12	.360	.085		.033	12	2.500
SAT-750-12	.360	.085	.750	.033	12	2.500
SAT-1000-12	.360	.085	1.000	.033	12	2.500
SAT-1250-12	.360	.085	1.250	.033	12	2.500
SAT-1800-12	.360	.085	1.800	.033	12	2.500
1/2" Shanks – D2						
SAT-750-10	.490	.120	.750	.037	10	3.000
SAT-1500-10	.490	.120	1.500	.037	10	3.000
SAT-2000-10	.490	.120	2.000	.037	10	3.000
SAT-2000-9	.490	.120	2.000	.042	9	3.000
SAT-750-8	.490	.120	.750	.048	8	3.000
SAT-1500-8	.490	.120	1.500	.048	8	3.000
SAT-2000-8	.490	.120	2.000	.048	8	3.000
SAT-750-7 ♦	.490	.120	.750	.055	7	3.000
SAT-2000-7	.490	.120	2.000	.055	7	3.000
SAT-2000-6	.490	.120	2.000	.065	6	3.000
SAT-750-5	.490	.120	.750	.079	5	3.000
SAT-1500-5	.490	.120	1.500	.079	5	3.000
SAT-2000-5	.490	.120	2.000	.079	5	3.000

♦ WHILE SUPPLIES LAST - Discontinued

Tolerances:

Shank Diameter: $-.0001"-.0003"$
 Minimum Bore Diameter: $+.000"-.005"$
 Maximum Bore Depth: $+.050"-.000"$
 "W" Flat: $\pm.001"$
 Overall Length: $\pm.015"$

**Page 274
for Coating
Info**

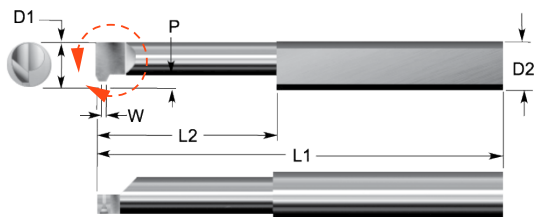
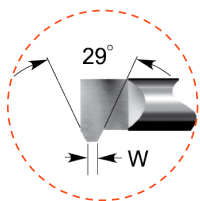
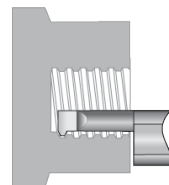

AITin – Add "X" to the end of Catalog No.

IAT Catalog No.	Minimum Bore Diameter (D1)	Projection (P)	Maximum Bore Depth (L2)	Offset Point (W)	Threads Per Inch (T.P.I.)	Overall Length (L1)
	inch	inch	inch	inch	inch	inch
1/4" Shanks – D2						
IAT-400-16	.200	.045	.400	.021	16	2.500
IAT-600-16	.200	.045	.600	.021	16	2.500
IAT-750-16	.200	.045	.750	.021	16	2.500
IAT-1000-16	.200	.045	1.000	.021	16	2.500
5/16" Shanks – D2						
IAT-500-14	.255	.070	.500	.024	14	2.500
IAT-750-14	.255	.070	.750	.024	14	2.500
IAT-1000-14	.255	.070	1.000	.024	14	2.500
IAT-1250-14	.255	.070	1.250	.024	14	2.500
3/8" Shanks – D2						
IAT-750-12	.360	.085	.750	.028	12	2.500
IAT-1000-12	.360	.085	1.000	.028	12	2.500
IAT-1250-12	.360	.085	1.250	.028	12	2.500
IAT-1800-12	.360	.085	1.800	.028	12	2.500
1/2" Shanks – D2						
IAT-750-10	.490	.120	.750	.032	10	3.000
IAT-1500-10	.490	.120	1.500	.032	10	3.000
IAT-2000-10	.490	.120	2.000	.032	10	3.000
IAT-750-8	.490	.120	.750	.041	8	3.000
IAT-1500-8	.490	.120	1.500	.041	8	3.000
IAT-2000-8	.490	.120	2.000	.041	8	3.000
IAT-750-6	.490	.120	.750	.057	6	3.000
IAT-1500-6	.490	.120	1.500	.057	6	3.000
IAT-2000-6	.490	.120	2.000	.057	6	3.000
IAT-1500-5	.490	.120	1.500	.069	5	3.000
IAT-2000-5	.490	.120	2.000	.069	5	3.000

For current pricing and availability please visit our website at www.micro100.com

A

Tolerances:
Shank Diameter: $-.0001"-.0003"$
Cutter Diameter: $+.000"-.005"$
Tool Radius:
 $.002"-.004"$, $.003"-.007"$,
 $.008"-.012"$
Maximum Depths: $+.050"-.000"$
Overall Length: $\pm .015"$

Page 274
for Coating
Info

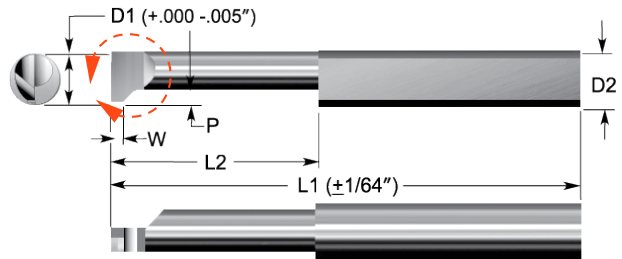
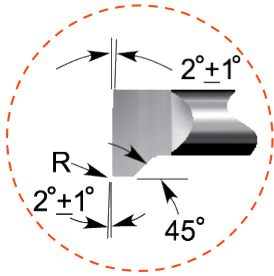
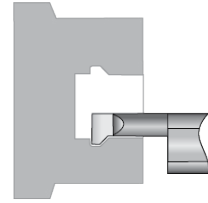
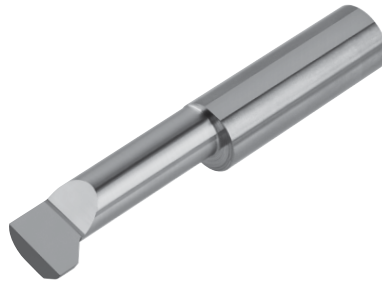

AITiN – Add “X” to the end of Catalog No.
LEFT HAND TOOLS AVAILABLE as SPECIALS.
Other sizes quoted upon request.

LTR Catalog No.	Minimum Minor Diameter (D1)	Projection (P)	Maximum Bore Depth (L2)	Flat (W)	Radius (R)	Overall Length (L1)
	inch	inch	inch	inch	inch	inch
1/8" Shanks – D2						
LTR-125-6	.125	.040	.375	.063	.002 - .004	1.500
3/16" Shanks – D2						
LTR-187-6	.187	.040	.375	.078	.003 - .007	2.000
LTR-187-12	.187	.040	.750	.078	.003 - .007	2.000
1/4" Shanks – D2						
LTR-250-8	.250	.050	.500	.094	.003 - .007	2.500
LTR-250-16	.250	.050	1.000	.094	.003 - .007	2.500
5/16" Shanks – D2						
LTR-312-12	.312	.075	.750	.094	.003 - .007	2.500
LTR-312-20	.312	.075	1.250	.094	.003 - .007	2.500
3/8" Shanks – D2						
LTR-375-12	.375	.100	.750	.125	.003 - .007	2.500
LTR-375-20	.375	.100	1.250	.125	.003 - .007	2.500
1/2" Shanks – D2						
LTR-500-16	.500	.125	1.000	.156	.008 - .012	3.000
LTR-500-24	.500	.125	1.500	.156	.008 - .012	3.000

For current pricing and availability please visit our website at www.micro100.com



FEATURING:

- Precision Ground Heat Treated Steel Shanks
- Two (2) lockdown screws at 90° for secure fastening.

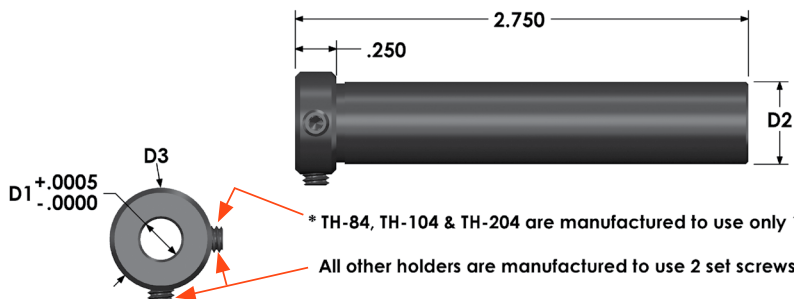

Metric sizes also available from stock

TH Catalog No.	Bore Diameter (D1) inch	Collar Diameter (D3) inch
1/2" Shanks – D2		
TH-84	1/8	5/8
TH-85	3/16	5/8
TH-86	1/4	5/8
TH-87	5/16	5/8
TH-88	3/8	5/8
5/8" Shanks – D2		
TH-104	1/8	3/4
TH-105	3/16	3/4
TH-106	1/4	3/4
TH-107	5/16	3/4
TH-108	3/8	3/4
3/4" Shanks – D2		
TH-204	1/8	7/8
TH-205	3/16	7/8
TH-206	1/4	7/8
TH-207	5/16	7/8
TH-208	3/8	7/8
TH-210	1/2	7/8

For current pricing and availability please visit our website at www.micro100.com

A



Fitted in a finished case

No Extra Cost for :

- Hard Plastic Case
- Foam Protection
- Easy to Carry
- Great Organization
- Extra Durability

BB SETS Boring Tool Sets	
BB - 1	1/8" Shanks
BB-050300	
BB-060300	
BB-080300	
BB-100400	
BB-100600	
BB-110500	
BB - 2	3/16" Shanks
BB-120500	
BB-120700	
BB-140400	
BB-140700	
BB-160400	
BB-160750	
BB - 3	1/4" Shanks
BB-180500	
BB-180750	
BB-1801000	
BB - 3 (continued)	1/4" Shanks
BB-200400	
BB-200600	
BB-2001000	
BB - 4	5/16" Shanks
BB-230400	
BB-230600	
BB-230800	
BB-2301000	
BB-290500	
BB-2901000	
BB - 5	3/8" Shanks
BB-320500	
BB-3201000	
BB-3201500	
BB-360750	
BB-3601250	
BB-3601800	





MBB Miniture Boring Tool Sets	
MBB - 0	1/8" Shanks
MBB-020075	
MBB-025100	
MBB-030100	
MBB-035100	
MBB-040150	
MBB-045150	



RR SETS Retaining Ring Grooving Tool Sets		
RR - 1	1/4, 5/16 Shanks	
RR-017-4		1/4"
RR-025-10		1/4"
RR-030-8		1/4"
RR-030-10		1/4"
RR-038-8		5/16"
RR-038-12		5/16"
RR - 2	3/8" Shanks	
RR-039-12		
RR-046-16		
RR-055-20		
RR-062-12		
RR-087-12		
RR-087-20		



IT SET Internal Threading Tool Sets		
IT - 1	1/4, 5/16 & 3/8 Shanks	
IT-180500		1/4"
IT-200600		1/4"
IT-230600		5/16"
IT-290750		5/16"
IT-320750		3/8"
IT-360750		3/8"

For current pricing and availability please visit our website at www.micro100.com

Advantages of the **MICRO 100** Coating Services:

Page 274
for Coating
Info



- Guaranteed Efficient Coating Procedures
- Guaranteed Quality
- Timely Turn-a-Rounds
- State of the Art Coating Technologies
- Added Performance and Value to Cutting Tools
- Customer Service for Advice and Recommendations

MICRO 100 Coating Services and Capabilities:

- TIN (titanium nitride)
- AlTiN (aluminum titanium nitride)
- ZrN (zirconium nitride)
- Nano-Tek / CR w/Polish (aluminum titanium nitride nano)
- Coat both Single and Double End Tools
- 1/8" up to 1" Shanks
- 3mm up to 25mm Shanks
- Overall tool lengths up to 6"
- Overall tool lengths up to 153 mm



For more details on this service and any other questions you may have concerning the High Quality, Super Carbide Products manufactured by **MICRO 100** Tool Corporation... contact us today at 1-800-421-8065!

MICRO 100[®]
super carbide tools

*Provides Solid Carbide Tooling for Vastly Increased Speed
and Feed Rates for Cutting Aluminum, Brass, Copper,
Stainless Steels, High Temperature Alloys,
Thermoplastics and Composites.*



B

- Reduce Machine Setup
 - Reduce Downtime
 - Reduce Tooling Costs
 - Reduce Tooling Inventories
- while... **BOOSTING PRODUCTIVITY!**

- Miniature Boring and Grooving Tools
- Boring Tools with Top Rake Chipbreakers
- Boring Tools for Milling Machines
- Reverse Boring Tools
- Full Radius and Retaining Ring Grooving Tools
- Boring and Profiling Tools
- Face Grooving Tools
- Internal Threading Tools
- Spotting and Centering Tools
- Countersink and Chamfering Tools
- Spade Drills
- Combined Drill and Countersink Tools
- Quik-Change Carbide Blanks
- Tool Holder Centerline Indicating Tools
- Standard and Specialized Tool Holders



**WILL NOT CHIP OR BREAK
UNDER NORMAL MACHINING CONDITIONS**



B

Miniature Boring Tools

Style QMBB
page 40

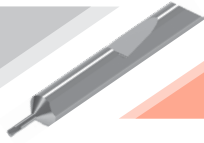

Miniature Retaining Ring Grooving Tools

Styles QMRR
page 51

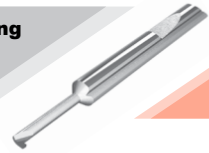

Boring Tools

Style QBB
pages 41 - 43

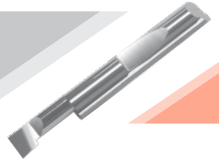

Retaining Ring Grooving Tools

Style QRR
pages 52 - 54

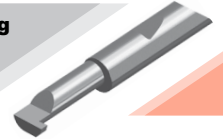

Boring Tools

with Top Rake Chipbreakers
Style QBT
pages 44, 45

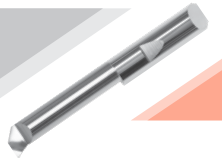

Miniature Full Radius Grooving Tools

Styles QMFR
page 55

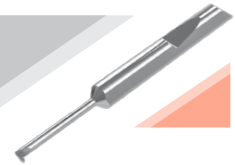

Reverse Boring Tools

Style QRB
page 46

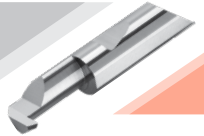

Full Radius Grooving Tools

Style QFR
pages 56 - 58



Boring Tools for Milling Machines

Style QBM
page 47

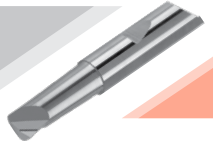

Face Grooving Tools

Style QFG
page 59



Boring & Profiling Tools

Style QPF
pages 48, 49

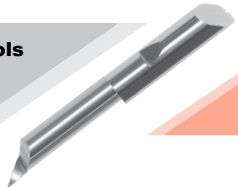

Internal Threading Tools

Style QIT
pages 60 - 62

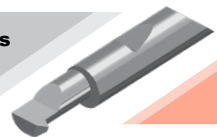

Profiling Tools

Style QPR
page 50

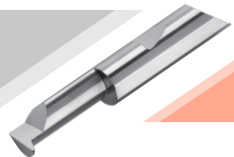

Spotting and Centering Tools

Style QSPD
page 63

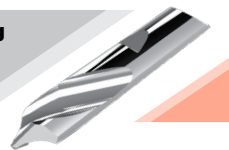

For current pricing and availability please visit our website at www.micro100.com

Countersink Tools
Style QCS
page 64



Standard Tool Holders
Styles QTH & QTHM
pages 70, 71



Spade Drills
Styles QSD
page 65



Thru Coolant Tool Holders
Style QTC-QTCM
pages 72, 73



Combined Drill & Countersink Tools
Styles QDC
page 66



Specialized Tool Holders
STAR CNC Machines
Style QZST
pages 75 - 77



Carbide Tooling Blanks
Styles QSP/QSR
page 67



Square Shank Tool Holders
Styles QSG
page 78



Tool Holder Centerline Indicating Tools
Style QI
page 68



Accessories
page 80



Modular Tool Holder System
Style QDH
page 69



Technical Data
page 273



Modular Tool Holder System
Styles QDS & QDSM
page 69



Tolerances:

Shank Diameter:
-.0001" (-.0025mm)
-.0003" (-.0076mm)
Minimum Bore Diameter:
±.0005" (±.013mm)
Maximum Bore Depth:
+.030" (.76mm)-0"

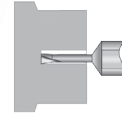
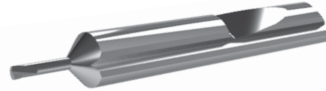

B

Page 274
for Coating
Info

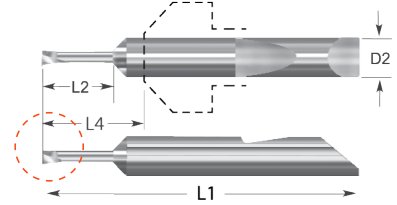
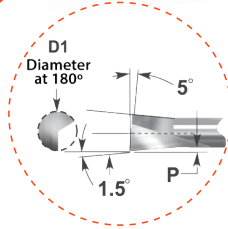

AlTiN – Add "X" to the end of Catalog No.
LEFT HAND TOOLS AVAILABLE as SPECIALS.

QMBB Catalog No.	Minimum Bore Diameter (D1)		Maximum Bore Depth (L2)		Projection (P)		Length from Holder (L4)		Overall Length (L1)
	inch	mm	inch	mm	inch	mm	inch	mm	inch
3/16" / 4.8mm Shanks – D2									
QMBB-015050	.015	0.38	.050	1.27	.005	.13	.590	14.99	1.500
QMBB-020075	.020	0.51	.075	1.91	.005	.13	.590	14.99	1.500
QMBB-025100	.025	0.64	.100	2.54	.005	.13	.590	14.99	1.500
QMBB-030100	.030	0.76	.100	2.54	.005	.13	.590	14.99	1.500
QMBB-035100	.035	0.89	.100	2.54	.005	.13	.590	14.99	1.500
QMBB-035150	.035	0.89	.150	3.81	.005	.13	.590	14.99	1.500
QMBB-040150	.040	1.016	.150	3.81	.005	.13	.590	14.99	1.500
QMBB-040200	.040	1.016	.200	5.08	.005	.13	.590	14.99	1.500
QMBB-045150	.045	1.14	.150	3.81	.005	.13	.590	14.99	1.500
QMBB-045200	.045	1.14	.200	5.08	.005	.13	.590	14.99	1.500
QMBB-050150	.050	1.27	.150	3.81	.013	.33	.590	14.99	1.500
QMBB-050200	.050	1.27	.200	5.08	.013	.33	.590	14.99	1.500
QMBB-050300	.050	1.27	.300	7.62	.013	.33	.590	14.99	1.500
QMBB-060150	.060	1.52	.150	3.81	.015	.38	.590	14.99	1.500
QMBB-060200	.060	1.52	.200	5.08	.015	.38	.590	14.99	1.500
QMBB-060300	.060	1.52	.300	7.62	.015	.38	.590	14.99	1.500
QMBB-060400	.060	1.52	.400	10.16	.015	.38	.590	14.99	1.500
QMBB-060500	.060	1.52	.500	12.70	.015	.38	.590	14.99	1.500
QMBB-070150	.070	1.78	.150	3.81	.015	.38	.590	14.99	1.500
QMBB-070200	.070	1.78	.200	5.08	.015	.38	.590	14.99	1.500
QMBB-070300	.070	1.78	.300	7.62	.015	.38	.590	14.99	1.500
QMBB-070400	.070	1.78	.400	10.16	.015	.38	.590	14.99	1.500
QMBB-070500	.070	1.78	.500	12.70	.015	.38	.590	14.99	1.500
QMBB-080150	.080	2.032	.150	3.81	.020	.51	.590	14.99	1.500
QMBB-080200	.080	2.032	.200	5.08	.020	.51	.590	14.99	1.500
QMBB-080300	.080	2.032	.300	7.62	.020	.51	.590	14.99	1.500
QMBB-080500	.080	2.032	.500	12.70	.020	.51	.590	14.99	1.500
QMBB-080600	.080	2.032	.600	15.24	.020	.51	1.090	27.67	2.000
QMBB-090300	.090	2.29	.300	7.62	.020	.51	.590	14.99	1.500
QMBB-090500	.090	2.29	.500	12.70	.020	.51	.590	14.99	1.500
QMBB-090700	.090	2.29	.700	17.78	.020	.51	1.090	27.67	2.000
QMBB-100300	.100	2.54	.300	7.62	.025	.64	.590	14.99	1.500
QMBB-100500	.100	2.54	.500	12.70	.025	.64	.590	14.99	1.500
QMBB-100700	.100	2.54	.700	17.78	.025	.64	1.090	27.67	2.000
QMBB-100800	.100	2.54	.800	20.32	.025	.64	1.090	27.67	2.000

Tolerances:

Shank Diameter:
-.0001"(-.0025mm)-.0003"(-.0076mm)
Minimum Bore Diameter:
±.0005"(±.013mm)
Maximum Bore Depth:
+.030"(+.76mm)-0"
Tool Radius: +.003"(.076mm)-0"

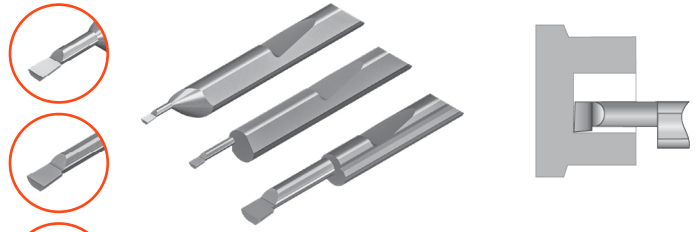

Page 274
for Coating
Info

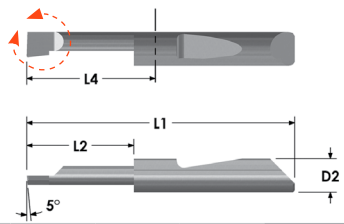
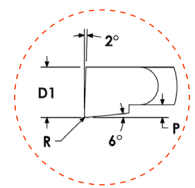
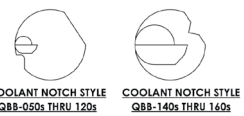

AITiN – Add “X” to the end of Catalog No.
LEFT HAND TOOLS AVAILABLE as SPECIALS.

QBB Catalog No.	Minimum Bore Diameter (D1)		Maximum Bore Depth (L2)		Projection (P)		Tool Radius (R)		Length from Holder (L4)		Overall Length (L1)
	inch	mm	inch	mm	inch	mm	inch	mm	inch	mm	inch
3/16" / 4.8mm Shanks – D2											
QBB-050150	.050	1.27	.150	3.81	.013	.33	SHARP	SHARP	.590	14.99	1.500
QBB-050200	.050	1.27	.200	5.08	.013	.33	SHARP	SHARP	.590	14.99	1.500
QBB-050300	.050	1.27	.300	7.62	.013	.33	SHARP	SHARP	.590	14.99	1.500
QBB-050400	.050	1.27	.400	10.16	.013	.33	SHARP	SHARP	.590	14.99	1.500
QBB-060150	.060	1.52	.150	3.81	.015	.38	SHARP	SHARP	.590	14.99	1.500
QBB-060200	.060	1.52	.200	5.08	.015	.38	SHARP	SHARP	.590	14.99	1.500
QBB-060300	.060	1.52	.300	7.62	.015	.38	SHARP	SHARP	.590	14.99	1.500
QBB-060400	.060	1.52	.400	10.16	.015	.38	SHARP	SHARP	.590	14.99	1.500
QBB-060500	.060	1.52	.500	12.70	.015	.38	SHARP	SHARP	.590	14.99	1.500
QBB-080200	.080	2.032	.200	5.08	.020	.51	SHARP	SHARP	.590	14.99	1.500
QBB-080300	.080	2.032	.300	7.62	.020	.51	SHARP	SHARP	.590	14.99	1.500
QBB-080500	.080	2.032	.500	12.70	.020	.51	SHARP	SHARP	.590	14.99	1.500
QBB-080600	.080	2.032	.600	15.24	.020	.51	SHARP	SHARP	1.090	27.67	2.000
QBB-100200	.100	2.54	.200	5.08	.025	.64	SHARP	SHARP	.590	14.99	1.500
QBB-100300	.100	2.54	.300	7.62	.025	.64	SHARP	SHARP	.590	14.99	1.500
QBB-100500	.100	2.54	.500	12.70	.025	.64	SHARP	SHARP	.590	14.99	1.500
QBB-100700	.100	2.54	.700	17.78	.025	.64	SHARP	SHARP	1.090	27.67	1.500
QBB-110300	.110	2.79	.300	7.62	.028	.71	.003	.076	.590	14.99	1.500
QBB-110500	.110	2.79	.500	12.70	.028	.71	.003	.076	.590	14.99	1.500
QBB-110700	.110	2.79	.700	17.78	.028	.71	.003	.076	1.090	27.67	2.000
QBB-120250	.120	3.048	.250	6.35	.030	.76	.003	.076	.590	14.99	1.500
QBB-120350	.120	3.048	.350	8.89	.030	.76	.003	.076	.590	14.99	1.500
QBB-120500	.120	3.048	.500	12.70	.030	.76	.003	.076	.590	14.99	1.500
QBB-120700	.120	3.048	.700	17.78	.030	.76	.003	.076	1.090	27.67	2.000
QBB-120800	.120	3.048	.800	20.32	.030	.76	.003	.076	.590	14.99	2.000
QBB-140400	.140	3.56	.400	10.16	.035	.89	.003	.076	.590	14.99	1.500
QBB-140600	.140	3.56	.600	15.24	.035	.89	.003	.076	1.090	27.67	2.000
QBB-140800	.140	3.56	.800	20.32	.035	.89	.003	.076	1.090	27.67	2.000
QBB-160400	.160	4.064	.400	10.16	.040	1.016	.003	.076	.590	14.99	1.500
QBB-160600	.160	4.064	.600	15.24	.040	1.016	.003	.076	1.090	27.67	2.000
QBB-160750	.160	4.064	.750	19.05	.040	1.016	.003	.076	1.090	27.67	2.000
QBB-1601000	.160	4.064	1.000	25.40	.040	1.016	.003	.076	1.090	27.67	2.000

Tolerances:

Shank Diameter:

$-.0001"(-.0025mm)-.0003"(-.0076mm)$

Minimum Bore Diameter:

$+.0005"(\pm .013mm)$

Maximum Bore Depth:

$+.030"(+.76mm)-0"$

Tool Radius:

$+.003"(.076mm)-0"$

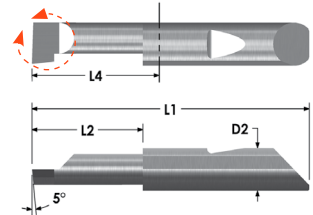
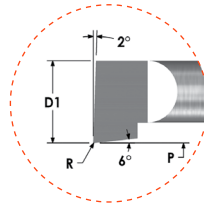
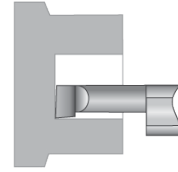
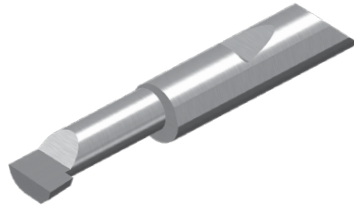

B

AlTiN – Add “X” to the end of Catalog No.
LEFT HAND TOOLS AVAILABLE as SPECIALS.

Other sizes quoted upon request.

QBB Catalog No.	Minimum Bore Diameter (D1)		Maximum Bore Depth (L2)		Projection (P)		Tool Radius (R)		Length from Holder (L4)		Overall Length (L1)
	inch	mm	inch	mm	inch	mm	inch	mm	inch	mm	inch
1/4" / 6.4mm Shanks – D2											
QBB-180500	.180	4.57	.500	12.70	.045	1.14	.005	.13	.853	21.67	2.000
QBB-180750	.180	4.57	.750	19.05	.045	1.14	.005	.13	1.353	34.37	2.000
QBB-1801000	.180	4.57	1.000	25.40	.045	1.14	.005	.13	1.853	47.07	2.500
QBB-1801250	.180	4.57	1.250	31.75	.045	1.14	.005	.13	.853	21.67	2.500
QBB-1801500	.180	4.57	1.500	38.10	.045	1.14	.005	.13	1.353	34.37	3.000
QBB-200500	.200	5.08	.500	12.70	.050	1.27	.005	.13	1.853	47.07	2.000
QBB-200750	.200	5.08	.750	19.05	.050	1.27	.005	.13	.853	21.67	2.000
QBB-2001000	.200	5.08	1.000	25.40	.050	1.27	.005	.13	1.353	34.37	2.500
QBB-2001200	.200	5.08	1.200	30.48	.050	1.27	.005	.13	1.353	34.37	2.500
QBB-2001500	.200	5.08	1.500	38.10	.050	1.27	.005	.13	1.853	47.07	3.000
5/16" / 7.9mm Shanks – D2											
QBB-230500	.230	5.84	.500	12.70	.058	1.47	.005	.13	.853	21.67	2.000
QBB-230750	.230	5.84	.750	19.05	.058	1.47	.005	.13	.853	21.67	2.000
QBB-2301000	.230	5.84	1.000	25.40	.058	1.47	.005	.13	1.353	34.37	2.500
QBB-2301250	.230	5.84	1.250	31.75	.058	1.47	.005	.13	1.353	34.37	2.500
QBB-2301500	.230	5.84	1.500	38.10	.058	1.47	.005	.13	1.853	47.07	3.000
QBB-2301600	.230	5.84	1.600	40.64	.058	1.47	.005	.13	1.853	47.07	3.000
QBB-290500	.290	7.37	.500	12.70	.073	1.85	.005	.13	.853	21.67	2.000
QBB-290750	.290	7.37	.750	19.05	.073	1.85	.005	.13	.853	21.67	2.000
QBB-2901000	.290	7.37	1.000	25.40	.073	1.85	.005	.13	1.353	34.37	2.500
QBB-2901250	.290	7.37	1.250	31.75	.073	1.85	.005	.13	1.353	34.37	2.500
QBB-2901500	.290	7.37	1.500	38.10	.073	1.85	.005	.13	1.853	47.07	3.000
QBB-2901750	.290	7.37	1.750	44.45	.073	1.85	.005	.13	1.853	47.07	3.000

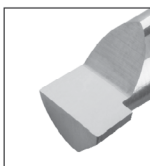

Tool Holders available in both
Inch or Metric Shank Sizes.

Standard or Extended
Lengths.



Tolerances:

Shank Diameter:

-.0001"(-.0025mm)-.0003"(-.0076mm)

Minimum Bore Diameter:

+ .0005"(±.013mm)

Maximum Bore Depth:

+.030"(+.76mm)-0"

Tool Radius:

+.003"(.076mm)-0"

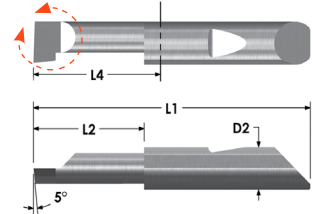
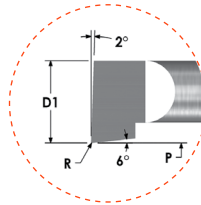
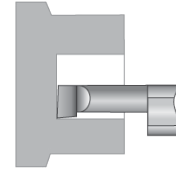
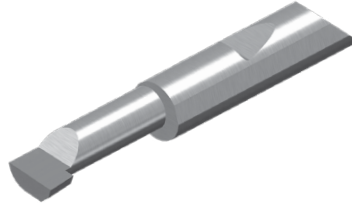

Page 274
for Coating
Info

AITiN – Add "X" to the end of Catalog No.
LEFT HAND TOOLS AVAILABLE as SPECIALS.

Other sizes quoted upon request.

QBB Catalog No.	Minimum Bore Diameter (D1)		Maximum Bore Depth (L2)		Projection (P)		Tool Radius (R)		Length from Holder (L4)		Overall Length (L1)
	inch	mm	inch	mm	inch	mm	inch	mm	inch	mm	inch
3/8" / 9.5mm Shanks – D2											
QBB-320500	.320	8.13	.500	12.70	.080	2.032	.005	.13	.853	21.67	2.000
QBB-320750	.320	8.13	.750	19.05	.080	2.032	.005	.13	.853	21.67	2.000
QBB-3201000	.320	8.13	1.000	25.40	.080	2.032	.005	.13	1.353	34.37	2.500
QBB-3201250	.320	8.13	1.250	31.75	.080	2.032	.005	.13	1.353	34.37	2.500
QBB-3201500	.320	8.13	1.500	38.10	.080	2.032	.005	.13	1.853	47.07	3.000
QBB-3201800	.320	8.13	1.800	45.72	.080	2.032	.005	.13	1.853	47.07	3.000
QBB-3202000	.320	8.13	2.000	50.80	.080	2.032	.005	.13	2.353	59.77	3.500
QBB-3202500	.320	8.13	2.500	63.50	.080	2.032	.005	.13	2.853	72.47	4.000
QBB-360750	.360	9.14	.750	19.05	.090	2.29	.005	.13	.853	21.67	2.000
QBB-3601000	.360	9.14	1.000	25.40	.090	2.29	.005	.13	1.353	34.37	2.500
QBB-3601250	.360	9.14	1.250	31.75	.090	2.29	.005	.13	1.353	34.37	2.500
QBB-3601500	.360	9.14	1.500	38.10	.090	2.29	.005	.13	1.853	47.07	3.000
QBB-3601800	.360	9.14	1.800	45.72	.090	2.29	.005	.13	1.853	47.07	3.000
QBB-3602000	.360	9.14	2.000	50.80	.090	2.29	.005	.13	2.353	59.77	3.500
QBB-3602500	.360	9.14	2.500	63.50	.090	2.29	.005	.13	2.853	72.47	4.000
1/2" / 12.7mm Shanks – D2											
QBB-4601000	.460	11.68	1.000	25.40	.115	2.92	.005	.13	1.040	26.42	2.500
QBB-4601250	.460	11.68	1.250	31.75	.115	2.92	.005	.13	1.540	39.12	3.000
QBB-4601500	.460	11.68	1.500	38.10	.115	2.92	.005	.13	1.540	39.12	3.000
QBB-4602000	.460	11.68	2.000	50.80	.115	2.92	.005	.13	2.040	51.82	3.500
QBB-4602500	.460	11.68	2.500	63.50	.115	2.92	.005	.13	2.540	64.52	4.000
QBB-4603000	.460	11.68	3.000	76.20	.115	2.92	.005	.13	3.040	77.22	4.500
QBB-4901000	.490	12.45	1.000	25.40	.123	3.12	.005	.13	1.040	26.42	2.500
QBB-4901250	.490	12.45	1.250	31.75	.123	3.12	.005	.13	1.540	39.12	3.000
QBB-4901500	.490	12.45	1.500	38.10	.123	3.12	.005	.13	1.540	39.12	3.000
QBB-4902000	.490	12.45	2.000	50.80	.123	3.12	.005	.13	2.040	51.82	3.500
QBB-4902500	.490	12.45	2.500	63.50	.123	3.12	.005	.13	2.540	64.52	4.000
QBB-4903000	.490	12.45	3.000	76.20	.123	3.12	.005	.13	3.040	77.22	4.500

For current pricing and availability please visit our website at www.micro100.com

B

Tolerances:
Shank Diameter:
-.0001"(-.0025mm)-.0003"(-.0076mm)
Minimum Bore Diameter:
±.0005"(±.013mm)
Maximum Bore Depth:
+.030"(+.76mm)-0"
Tool Radius:
±.0005"(±.013mm)

Page 274
for Coating
Info

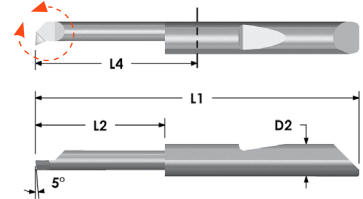
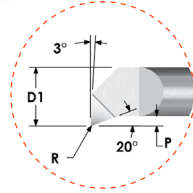
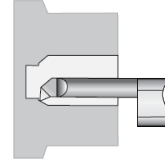
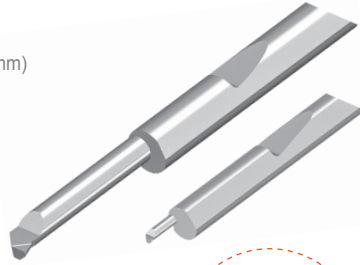

AITiN – Add "X" to the end of Catalog No.
Other sizes quoted upon request.

QBT Catalog No.	Minimum Bore Diameter (D1)		Maximum Bore Depth (L2)		Projection (P)		Tool Radius (R)		Length From Holder (L4)		Overall Length (L1)
	inch	mm	inch	mm	inch	mm	inch	mm	inch	mm	inch
3/16" / 4.8mm Shanks – D2											
QBT-050200	.050	1.27	.200	5.08	.005	.13	.002	.05	.590	14.99	1.500
QBT-050400	.050	1.27	.400	10.16	.005	.13	.002	.05	.590	14.99	1.500
QBT-050500	.050	1.27	.500	12.70	.005	.13	.002	.05	.590	14.99	1.500
QBT-060200	.060	1.52	.200	5.08	.010	.25	.002	.05	.590	14.99	1.500
QBT-060400	.060	1.52	.400	10.16	.010	.25	.002	.05	.590	14.99	1.500
QBT-060500	.060	1.52	.500	12.70	.010	.25	.002	.05	.590	14.99	1.500
QBT-070200	.070	1.78	.200	5.08	.015	.38	.004	.10	.590	14.99	1.500
QBT-070400	.070	1.78	.400	10.16	.015	.38	.004	.10	.590	14.99	1.500
QBT-070600	.070	1.78	.600	15.24	.015	.38	.004	.10	1.090	27.69	2.000
QBT-110250	.110	2.79	.250	6.35	.015	.38	.004	.10	.590	14.99	1.500
QBT-110500	.110	2.79	.500	12.70	.015	.38	.004	.10	.590	14.99	1.500
QBT-110750	.110	2.79	.750	19.05	.015	.38	.004	.10	1.090	27.69	2.000
QBT-120250	.120	3.05	.250	6.35	.020	.51	.004	.10	.590	14.99	1.500
QBT-120500	.120	3.05	.500	12.70	.020	.51	.004	.10	.590	14.99	1.500
QBT-120750	.120	3.05	.750	19.05	.020	.51	.004	.10	1.090	27.69	2.000
QBT-1201000	.120	3.05	1.000	25.40	.020	.51	.004	.10	1.090	27.69	2.000
QBT-160500	.160	4.06	.500	12.70	.025	.64	.006	.15	.590	14.99	1.500
QBT-160750	.160	4.06	.750	19.05	.025	.64	.006	.15	1.090	27.69	2.000
QBT-1601000	.160	4.06	1.000	25.40	.025	.64	.006	.15	1.090	27.69	2.000
QBT-1601250	.160	4.06	1.250	31.75	.025	.64	.006	.15	1.590	40.39	2.500
1/4" / 6.4mm Shanks – D2											
QBT-180500	.180	4.57	.500	12.70	.030	.76	.006	.15	.853	21.69	2.000
QBT-180750	.180	4.57	.750	19.05	.030	.76	.006	.15	.853	21.69	2.000
QBT-1801000	.180	4.57	1.000	25.40	.030	.76	.006	.15	1.353	34.37	2.500
QBT-1801250	.180	4.57	1.250	31.75	.030	.76	.006	.15	1.353	34.37	2.500
QBT-1801500	.180	4.57	1.500	38.10	.030	.76	.006	.15	1.853	47.07	3.000
QBT-200600	.200	5.08	.600	15.24	.030	.76	.006	.15	.853	21.69	2.000
QBT-2001000	.200	5.08	1.000	25.40	.030	.76	.006	.15	1.353	34.37	2.500
QBT-2001250	.200	5.08	1.250	31.75	.030	.76	.006	.15	1.353	34.37	2.500
QBT-2001500	.200	5.08	1.500	38.10	.030	.76	.006	.15	1.853	47.07	3.000

For current pricing and availability please visit our website at www.micro100.com

Tolerances:

Shank Diameter:

-.0001"(-.0025mm)-.0003"(-.0076mm)

Minimum Bore Diameter:

+ .0005" (+.013mm)

Maximum Bore Depth:

+ .030" (+.76mm)-0"

Tool Radius:

±.0005" (±.013mm)

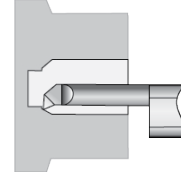
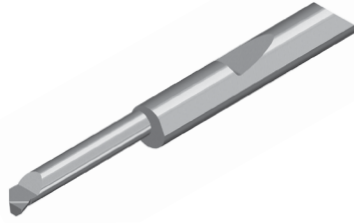

Page 274
for Coating
Info

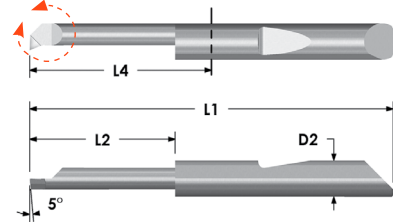
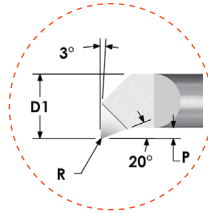

AITiN – Add "X" to the end of Catalog No.

Other sizes quoted upon request.

QBT Catalog No.	Minimum Bore Diameter (D1)		Maximum Bore Depth (L2)		Projection (P)		Tool Radius (R)		Length From Holder (L4)		Overall Length (L1)
	inch	mm	inch	mm	inch	mm	inch	mm	inch	mm	inch
5/16" / 7.9mm Shanks – D2											
QBT-230750	.230	5.84	.750	19.05	.040	1.02	.006	.15	.853	21.67	2.000
QBT-2301100	.230	5.84	1.100	27.94	.040	1.02	.006	.15	1.353	34.37	2.500
QBT-2301300	.230	5.84	1.300	33.02	.040	1.02	.006	.15	1.353	34.37	2.500
QBT-2301600	.230	5.84	1.600	40.64	.040	1.02	.006	.15	1.853	47.07	3.000
3/8" / 9.5mm Shanks – D2											
QBT-3001000	.300	7.62	1.000	25.40	.050	1.27	.006	.15	1.353	34.37	2.500
QBT-3001600	.300	7.62	1.600	40.64	.050	1.27	.006	.15	1.853	47.07	3.000
QBT-3002100	.300	7.62	2.100	53.34	.050	1.27	.006	.15	2.353	59.77	3.500
QBT-3601000	.360	9.14	1.000	25.40	.050	1.27	.006	.15	1.353	34.37	2.500
QBT-3601600	.360	9.14	1.600	40.64	.050	1.27	.006	.15	1.853	47.07	3.000
QBT-3602100	.360	9.14	2.100	53.34	.050	1.27	.006	.15	2.353	59.77	3.500
1/2" / 12.7mm Shanks – D2											
QBT-4601000	.460	11.68	1.000	25.40	.075	1.91	.006	.15	1.040	26.42	2.500
QBT-4601600	.460	11.68	1.600	40.64	.075	1.91	.006	.15	2.040	51.82	3.500
QBT-4602100	.460	11.68	2.100	53.34	.075	1.91	.006	.15	2.540	64.52	4.000
QBT-4901000	.490	12.45	1.000	25.40	.075	1.91	.006	.15	1.040	26.42	2.500
QBT-4901600	.490	12.45	1.600	40.64	.075	1.91	.006	.15	2.040	51.82	3.500
QBT-4902100	.490	12.45	2.100	53.34	.075	1.91	.006	.15	2.540	64.52	4.000

Tool Holders Available

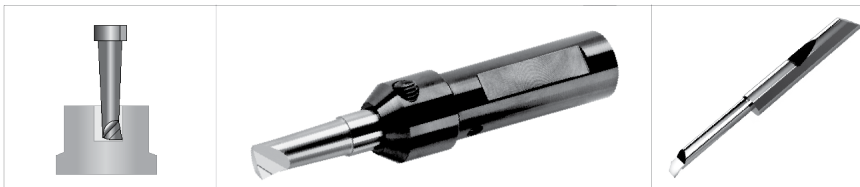

For current pricing and availability please visit our website at www.micro100.com

Tolerances:

Shank Diameter:
-.0001"(-.0025mm)-.0003"(-.0076mm)
Minimum Bore Diameter:
+.0005"(±.013mm)
Maximum Bore Depth:
+.030"(+.76mm)-0"
Tool Radius: ±.001"(.025mm)

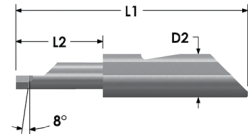
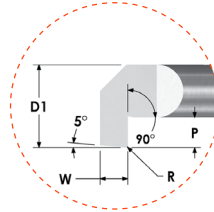
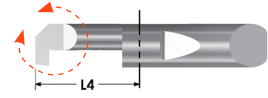
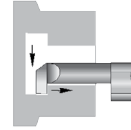
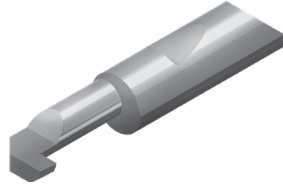

B

Page 274
for Coating
Info

AITIN – Add "X" to the end of Catalog No.

Other sizes quoted upon request.

QRB Catalog No.	Minimum Bore Diameter (D1)		Maximum Bore Depth (L2)		Tooth Width (W)		Projection (P)		Tool Radius (R)		Length From Holder (L4)		Overall Length (L1)
	inch	mm	inch	mm	inch	mm	inch	mm	inch	mm	inch	mm	inch
3/16" / 4.8mm Shanks – D2													
QRB-156500	.156	3.96	.500	12.70	.075	1.91	.060	1.52	.005	.13	.590	14.99	1.500
QRB-156750	.156	3.96	.750	19.05	.075	1.91	.060	1.52	.005	.13	1.090	27.67	2.000
QRB-1561000	.156	3.96	1.000	25.40	.075	1.91	.060	1.52	.005	.13	1.090	27.67	2.000
1/4" / 6.4mm Shanks – D2													
QRB-180500	.180	4.57	.500	12.70	.100	2.54	.080	2.03	.005	.13	.853	21.67	2.000
QRB-180750	.180	4.57	.750	19.05	.100	2.54	.080	2.03	.005	.13	1.353	34.37	2.500
QRB-1801000	.180	4.57	1.000	25.40	.100	2.54	.080	2.03	.005	.13	1.353	34.37	2.500
QRB-200500	.200	5.08	.500	12.70	.113	2.87	.090	2.29	.008	.20	.853	21.67	2.000
QRB-200750	.200	5.08	.750	19.05	.113	2.87	.090	2.29	.008	.20	1.353	34.37	2.500
QRB-2001000	.200	5.08	1.000	25.40	.113	2.87	.090	2.29	.008	.20	1.353	34.37	2.500
QRB-2001250	.200	5.08	1.250	31.75	.113	2.87	.090	2.29	.008	.20	1.853	47.07	3.000
5/16" / 7.9mm Shanks – D2													
QRB-230500	.230	5.84	.500	12.70	.138	3.51	.110	2.79	.008	.20	.853	21.67	2.000
QRB-230750	.230	5.84	.750	19.05	.138	3.51	.110	2.79	.008	.20	1.353	34.37	2.500
QRB-2301000	.230	5.84	1.000	25.40	.138	3.51	.110	2.79	.008	.20	1.353	34.37	2.500
QRB-2301250	.230	5.84	1.250	31.75	.138	3.51	.110	2.79	.008	.20	1.853	47.07	3.000
QRB-300500	.300	7.62	.500	12.70	.138	3.51	.110	2.79	.008	.20	.853	21.67	2.000
QRB-300750	.300	7.62	.750	19.05	.138	3.51	.110	2.79	.008	.20	1.353	34.37	2.500
QRB-3001000	.300	7.62	1.000	25.40	.138	3.51	.110	2.79	.008	.20	1.353	34.37	2.500
QRB-3001250	.300	7.62	1.250	31.75	.138	3.51	.110	2.79	.008	.20	1.853	47.07	3.000
3/8" / 9.5mm Shanks – D2													
QRB-360750	.360	9.14	.750	19.05	.163	4.14	.130	3.30	.008	.20	1.353	34.37	2.500
QRB-3601000	.360	9.14	1.000	25.40	.163	4.14	.130	3.30	.008	.20	1.353	34.37	2.500
QRB-3601250	.360	9.14	1.250	31.75	.163	4.14	.130	3.30	.008	.20	1.853	47.07	3.000
QRB-3601500	.360	9.14	1.500	38.10	.163	4.14	.130	3.30	.008	.20	1.853	47.07	3.000
1/2" / 12.7mm Shanks – D2													
QRB-4601000	.460	11.68	1.000	25.40	.200	5.08	.160	4.06	.008	.20	1.540	39.12	3.000
QRB-4601250	.460	11.68	1.250	31.75	.200	5.08	.160	4.06	.008	.20	1.540	39.12	3.000
QRB-4601500	.460	11.68	1.500	38.10	.200	5.08	.160	4.06	.008	.20	2.040	51.82	3.500
QRB-4601800	.460	11.68	1.800	45.72	.200	5.08	.160	4.06	.008	.20	2.040	51.82	3.500
QRB-4901000	.490	12.45	1.000	25.40	.200	5.08	.160	4.06	.008	.20	1.540	39.12	3.000
QRB-4901250	.490	12.45	1.250	31.75	.200	5.08	.160	4.06	.008	.20	1.540	39.12	3.000
QRB-4901500	.490	12.45	1.500	38.10	.200	5.08	.160	4.06	.008	.20	2.040	51.82	3.500
QRB-4901800	.490	12.45	1.800	45.72	.200	5.08	.160	4.06	.008	.20	2.040	51.82	3.500

Tolerances:

Shank Diameter:
-.0001"(-.0025mm)-.0003"(-.0076mm)
Centerline Offset:
±.0005"(±.013mm)
Maximum Bore Depth:
+.030"(+.76mm)-0"
Tool Radius: ±.001"(.025mm)

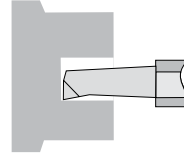

Page 274
for Coating
Info

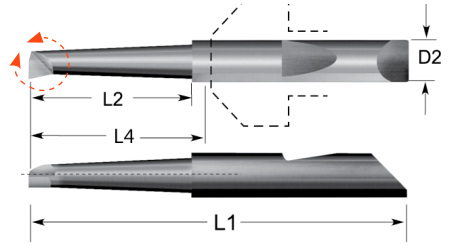
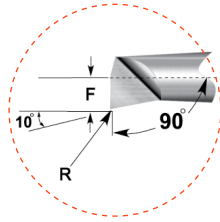

B

AITiN – Add “X” to the end of Catalog No.
Other sizes quoted upon request.

QBM Catalog No.	Centerline Offset (F)		Maximum Bore Depth (L2)		Tool Radius (R)		Length From Holder (L4)		Overall Length (L1)
	inch	metric	inch	metric	inch	metric	inch	metric	inch
1/4" / 6.4mm Shanks – D2									
QBM-118500	.055	1.40	.500	12.70	.003	.076	.853	21.67	2.000
QBM-118750	.055	1.40	.750	19.05	.003	.076	.853	21.67	2.000
QBM-150500	.071	1.80	.500	12.70	.003	.076	.853	21.67	2.000
QBM-150750	.071	1.80	.750	19.05	.003	.076	.853	21.67	2.000
QBM-200500	.095	2.41	.500	12.70	.008	.20	.853	21.67	2.000
QBM-200750	.095	2.41	.750	19.05	.008	.20	.853	21.67	2.000
QBM-2001250	.095	2.41	1.250	31.75	.008	.20	1.353	34.37	2.500
QBM-230750	.110	2.79	.750	19.05	.008	.20	.853	21.67	2.000
QBM-2301250	.110	2.79	1.250	31.75	.008	.20	1.353	34.37	2.500
QBM-2301500	.110	2.79	1.500	38.10	.008	.20	1.853	47.07	3.000
3/8" / 9.5mm Shanks – D2									
QBM-3001000	.145	3.68	1.000	25.40	.008	.20	1.353	34.37	2.500
QBM-3001500	.145	3.68	1.500	38.10	.008	.20	1.853	47.07	3.000
QBM-3001750	.145	3.68	1.750	44.45	.008	.20	1.853	47.07	3.000
QBM-3601000	.175	4.45	1.000	25.40	.008	.20	1.353	34.37	2.500
QBM-3601500	.175	4.45	1.500	38.10	.008	.20	1.853	47.07	3.000
QBM-3602000	.175	4.45	2.000	50.80	.008	.20	2.353	59.77	3.500
1/2" / 12.7mm Shanks – D2									
QBM-4601000	.225	5.72	1.000	25.40	.008	.20	1.040	26.42	2.500
QBM-4601500	.225	5.72	1.500	38.10	.008	.20	1.540	39.12	3.000
QBM-4602000	.225	5.72	2.000	50.80	.008	.20	2.040	51.82	3.500
QBM-4602500	.225	5.72	2.500	63.50	.008	.20	2.540	64.52	4.000
QBM-4603000	.225	5.72	3.000	76.20	.008	.20	3.040	77.22	4.500

For current pricing and availability please visit our website at www.micro100.com

Tolerances:

Shank Diameter:

-.0001"(-.0025mm)-.0003"(-.0076mm)

Minimum Bore Diameter:

±.0005"(±.013mm)

Maximum Bore Depth:

+.030"(+.76mm)-0"

Tool Radius: ±.0005"(±.013mm)

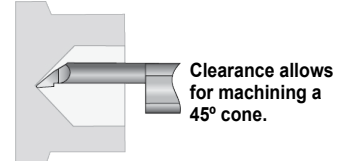
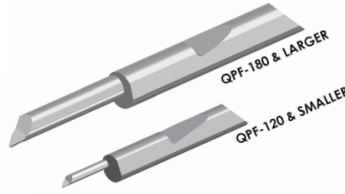

B

Page 274
for Coating
Info

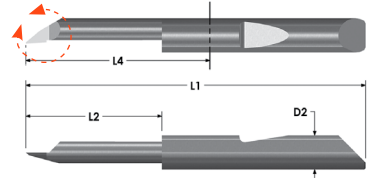
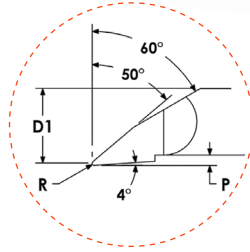

AITiN – Add "X" to the end of Catalog No.

Other sizes quoted upon request.

QPF Catalog No.	Minimum Bore Diameter (D1)		Maximum Bore Depth (L2)		Projection (P)		Tool Radius (R)		Length From Holder (L4)		Overall Length (L1)
	inch	mm	inch	mm	inch	mm	inch	mm	inch	mm	inch
3/16" / 4.8mm Shanks – D2											
QPF-050200	.050	1.27	.200	5.08	.005	.13	.005	.13	.590	14.99	1.500
QPF-050400	.050	1.27	.400	10.16	.005	.13	.005	.13	.590	14.99	1.500
QPF-050500	.050	1.27	.500	12.70	.005	.13	.005	.13	.590	14.99	1.500
QPF-060200	.060	1.52	.200	5.08	.005	.13	.005	.13	.590	14.99	1.500
QPF-060400	.060	1.52	.400	10.16	.005	.13	.005	.13	.590	14.99	1.500
QPF-060500	.060	1.52	.500	12.70	.005	.13	.005	.13	.590	14.99	1.500
QPF-070200	.070	1.78	.200	5.08	.010	.25	.005	.13	.590	14.99	1.500
QPF-070400	.070	1.78	.400	10.16	.010	.25	.005	.13	.590	14.99	1.500
QPF-070500	.070	1.78	.500	12.70	.010	.25	.005	.13	.590	14.99	1.500
QPF-070600	.070	1.78	.600	15.24	.010	.25	.005	.13	1.090	27.67	2.000
QPF-110250	.110	2.79	.250	6.35	.015	.38	.005	.13	.590	14.99	1.500
QPF-110500	.110	2.79	.500	12.70	.015	.38	.005	.13	.590	14.99	1.500
QPF-110750	.110	2.79	.750	15.24	.015	.38	.005	.13	1.090	27.67	2.000
QPF-120250	.120	3.05	.250	6.35	.020	.51	.008	.20	.590	14.99	1.500
QPF-120500	.120	3.05	.500	12.70	.020	.51	.008	.20	.590	14.99	1.500
QPF-120750	.120	3.05	.750	19.05	.020	.51	.008	.20	1.090	27.67	2.000
QPF-1201000	.120	3.05	1.000	25.40	.020	.51	.008	.20	1.090	27.67	2.000
QPF-160500	.160	4.06	.500	12.70	.030	.76	.008	.20	.590	14.99	1.500
QPF-160750	.160	4.06	.750	19.05	.030	.76	.008	.20	1.090	27.67	2.000
QPF-1601000	.160	4.06	1.000	25.40	.030	.76	.008	.20	1.090	27.67	2.000
1/4" / 6.4mm Shanks – D2											
QPF-180500	.180	4.57	.500	12.70	.030	.76	.008	.20	.853	21.67	2.000
QPF-180750	.180	4.57	.750	19.05	.030	.76	.008	.20	.853	21.67	2.000
QPF-1801000	.180	4.57	1.000	25.40	.030	.76	.008	.20	1.353	34.37	2.500
QPF-200600	.200	5.08	.600	15.24	.030	.76	.008	.20	.853	34.37	2.000
QPF-2001000	.200	5.08	1.000	25.40	.030	.76	.008	.20	1.353	34.37	2.500

Tolerances:

Shank Diameter:

-.0001"(-.0025mm)-.0003"(-.0076mm)

Minimum Bore Diameter:

±.0005"(±.013mm)

Maximum Bore Depth:

+0.030"(+.76mm)-0"

Tool Radius: ±.0005"(±.013mm)

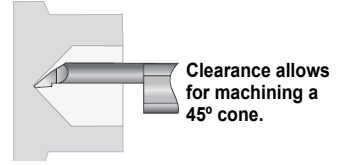
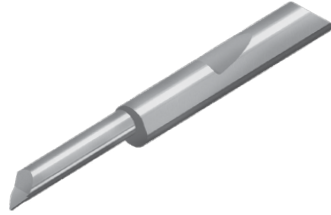

Page 274
for Coating
Info

B

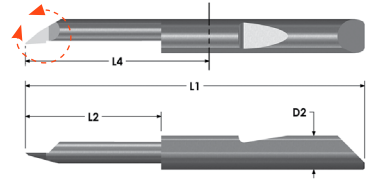
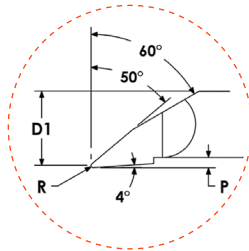

AITiN – Add "X" to the end of Catalog No.

Other sizes quoted upon request.

QPF Catalog No.	Minimum Bore Diameter (D1)		Maximum Bore Depth (L2)		Projection (P)		Tool Radius (R)		Length From Holder (L4)		Overall Length (L1)
	inch	mm	inch	mm	inch	mm	inch	mm	inch	mm	inch
5/16" / 7.9mm Shanks – D2											
QPF-230750	.230	5.84	.750	19.05	.030	.76	.008	.20	.853	21.67	2.000
QPF-2301000	.230	5.84	1.000	25.40	.030	.76	.008	.20	1.353	34.37	2.500
QPF-2301100	.230	5.84	1.100	27.94	.030	.76	.008	.20	1.353	34.37	2.500
QPF-2301250	.230	5.84	1.250	31.75	.030	.76	.008	.20	1.353	34.37	2.500
QPF-3001000	.300	7.62	1.000	25.40	.030	.76	.008	.20	1.353	34.37	2.500
QPF-3001250	.300	7.62	1.250	31.75	.030	.76	.008	.20	1.353	34.37	2.500
3/8" / 9.5mm Shanks – D2											
QPF-3601000	.360	9.14	1.000	25.40	.030	.76	.008	.20	1.353	34.37	2.500
QPF-3601250	.360	9.14	1.250	31.75	.030	.76	.008	.20	1.353	34.37	2.500
1/2" / 12.7mm Shanks – D2											
QPF-4601000	.460	11.68	1.000	25.40	.050	1.27	.008	.20	1.040	26.42	2.500
QPF-4601600 ♦	.460	11.68	1.600	40.64	.050	1.27	.008	.20	2.040	51.82	3.500
QPF-4601800 ♦	.460	11.68	1.800	45.72	.050	1.27	.008	.20	2.040	51.82	3.500
QPF-4901500 ♦	.490	12.50	1.500	38.10	.050	1.27	.008	.20	1.540	39.12	3.000
QPF-4901600 ♦	.490	12.50	1.600	40.64	.050	1.27	.008	.20	2.040	51.82	3.500
QPF-4901800 ♦	.490	12.50	1.800	45.72	.050	1.27	.008	.20	2.040	51.82	3.500
QPF-4902100 ♦	.490	12.50	2.100	53.34	.050	1.27	.008	.20	2.540	64.52	4.000

♦ WHILE SUPPLIES LAST - Discontinued

For current pricing and availability please visit our website at www.micro100.com

Tolerances:

Shank Diameter:
-.0001"(-.0025mm)-.0003"(-.0076mm)

Minimum Bore Diameter:
+.0005"(±.013mm)

Maximum Bore Depth:
+.030"(+.76mm)-0"

Tool Radius: ±.0005"(±.013mm)

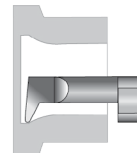
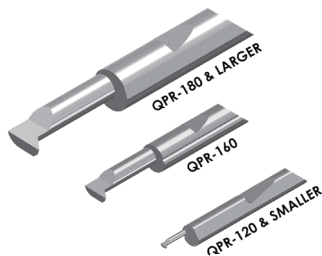

B

Page 274
for Coating
Info

COOLANT NOTCH STYLES



QPR-120 & SMALLER **QPR-160**

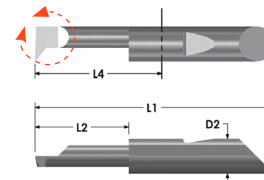
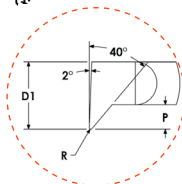

AITiN – Add "X" to the end of Catalog No.

Other sizes quoted upon request.

QPR Catalog No.	Minimum Bore Diameter (D1)		Maximum Bore Depth (L2)		Projection (P)		Tool Radius (R)		Length From Holder (L4)		Overall Length (L1)
	inch	mm	inch	mm	inch	mm	inch	mm	inch	mm	inch
3/16" / 4.8mm Shanks – D2											
QPR-070200	.070	1.78	.200	5.08	.025	.64	.005	.13	.590	14.99	1.500
QPR-070300	.070	1.78	.300	7.62	.025	.64	.005	.13	.590	14.99	1.500
QPR-070500	.070	1.78	.500	12.70	.025	.64	.005	.13	.590	14.99	1.500
QPR-110250	.110	2.79	.250	6.35	.040	1.02	.005	.13	.590	14.99	1.500
QPR-110500	.110	2.79	.500	12.70	.040	1.02	.005	.13	.590	14.99	1.500
QPR-120250	.120	3.05	.250	6.35	.050	1.27	.008	.20	.590	14.99	1.500
QPR-120500	.120	3.05	.500	12.70	.050	1.27	.008	.20	.590	14.99	1.500
QPR-120750	.120	3.05	.750	19.05	.050	1.27	.008	.20	1.090	27.67	2.000
QPR-160500	.160	4.06	.500	12.70	.050	1.27	.008	.20	.590	14.99	1.500
QPR-160750	.160	4.06	.750	19.05	.050	1.27	.008	.20	1.090	27.67	2.000
QPR-1601000	.160	4.06	1.000	25.40	.050	1.27	.008	.20	1.090	27.67	2.000
1/4" / 6.4mm Shanks – D2											
QPR-180500	.180	4.57	.500	12.70	.080	2.03	.008	.20	.853	21.67	2.000
QPR-180750	.180	4.57	.750	19.05	.080	2.03	.008	.20	.853	21.67	2.000
QPR-1801000	.180	4.57	1.000	25.40	.080	2.03	.008	.20	1.353	34.37	2.500
5/16" / 7.9mm Shanks – D2											
QPR-230750	.230	5.84	.750	19.05	.080	2.03	.008	.20	.853	21.67	2.000
QPR-2301000	.230	5.84	1.000	25.40	.080	2.03	.008	.20	1.353	34.37	2.500
QPR-2301250	.230	5.84	1.250	31.75	.080	2.03	.008	.20	1.353	34.37	2.500
QPR-3001000	.300	7.62	1.000	25.40	.110	2.79	.008	.20	1.353	34.37	2.500
QPR-3001250	.300	7.62	1.250	31.75	.110	2.79	.008	.20	1.353	34.37	2.500
3/8" / 9.5mm Shanks – D2											
QPR-3601000	.360	9.14	1.000	25.40	.130	3.30	.008	.20	1.353	34.37	2.500
QPR-3601250	.360	9.14	1.250	31.75	.130	3.30	.008	.20	1.353	34.37	2.500
1/2" / 12.7mm Shanks – D2											
QPR-4601000	.460	11.68	1.000	25.40	.150	3.81	.008	.20	1.040	26.42	3.000
QPR-4601500	.460	11.68	1.500	38.1	.150	3.81	.008	.20	1.540	39.10	3.000
QPR-4601800	.460	11.68	1.800	45.7	.150	3.81	.008	.20	2.040	51.82	3.500
QPR-4901000	.490	12.50	1.000	25.4	.150	3.81	.008	.20	1.040	26.42	3.000
QPR-4901500	.490	12.50	1.500	38.1	.150	3.81	.008	.20	1.540	39.10	3.000
QPR-4901800	.490	12.50	1.800	45.7	.150	3.81	.008	.20	2.040	51.82	3.500

Tolerances:

Groove Width:
+.002" (+.05mm)-0"
Shank Diameter:
-.0001" (-.0025mm)-.0003" (-.0076mm)
Minimum Bore Diameter:
±.0005" (±.013mm)
Maximum Bore Depth:
+.030" (+.76mm)-0"

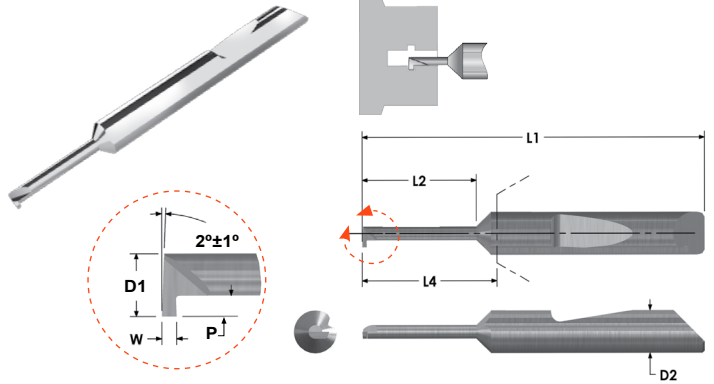

AITiN – Add “X” to the end of Catalog No.
Other sizes quoted upon request.

QMRR Catalog No.	Groove Width (W)		Projection (P)		Minimum Bore Diameter (D1)		Maximum Bore Depth (L2)		Length From Holder (L4)		Overall Length (L1)
	inch	mm	inch	mm	inch	mm	inch	mm	inch	mm	inch
3/16" / 4.8mm Shanks – D2											
QMRR-010-100-060	.010	.25	.020	.51	.060	1.52	.100	2.54	.590	14.99	1.500
QMRR-010-150-060	.010	.25	.020	.51	.060	1.52	.150	3.81	.590	14.99	1.500
QMRR-010-250-060	.010	.25	.020	.51	.060	1.52	.250	6.35	.590	14.99	1.500
QMRR-015-100-060	.015	.38	.020	.51	.060	1.52	.100	2.54	.590	14.99	1.500
QMRR-015-150-060	.015	.38	.020	.51	.060	1.52	.150	3.81	.590	14.99	1.500
QMRR-015-250-060	.015	.38	.020	.51	.060	1.52	.250	6.35	.590	14.99	1.500
QMRR-015-250-080	.015	.38	.025	.64	.080	2.03	.250	6.35	.590	14.99	1.500
QMRR-015-375-080	.015	.38	.025	.64	.080	2.03	.375	9.53	.590	14.99	1.500
QMRR-015-500-080	.015	.38	.025	.64	.080	2.03	.500	12.70	.590	14.99	1.500
QMRR-015-250-100	.015	.38	.030	.76	.100	2.54	.250	6.35	.590	14.99	1.500
QMRR-015-500-100	.015	.38	.030	.76	.100	2.54	.500	12.70	.590	14.99	1.500
QMRR-015-750-100	.015	.38	.030	.76	.100	2.54	.750	19.05	1.090	27.67	2.000
QMRR-020-100-060	.020	.51	.020	.51	.060	1.52	.100	2.54	.590	14.99	1.500
QMRR-020-150-060	.020	.51	.020	.51	.060	1.52	.150	3.81	.590	14.99	1.500
QMRR-020-250-060	.020	.51	.020	.51	.060	1.52	.250	6.35	.590	14.99	1.500
QMRR-020-250-080	.020	.51	.025	.64	.080	2.03	.250	6.35	.590	14.99	1.500
QMRR-020-375-080	.020	.51	.025	.64	.080	2.03	.375	9.53	.590	14.99	1.500
QMRR-020-500-080	.020	.51	.025	.64	.080	2.03	.500	12.70	.590	14.99	1.500
QMRR-020-250-100	.020	.51	.030	.76	.100	2.54	.250	6.35	.590	14.99	1.500
QMRR-020-500-100	.020	.51	.030	.76	.100	2.54	.500	12.70	.590	14.99	1.500
QMRR-020-750-100	.020	.51	.030	.76	.100	2.54	.750	19.05	1.090	27.67	2.000
QMRR-020-250-120	.020	.51	.040	1.02	.120	3.05	.250	6.35	.590	14.99	1.500
QMRR-020-500-120	.020	.51	.040	1.02	.120	3.05	.500	12.70	.590	14.99	1.500
QMRR-020-750-120	.020	.51	.040	1.02	.120	3.05	.750	19.05	1.090	27.67	2.000
QMRR-030-250-080	.030	.76	.025	.64	.080	2.03	.250	6.35	.590	14.99	1.500
QMRR-030-375-080	.030	.76	.025	.64	.080	2.03	.375	9.53	.590	14.99	1.500
QMRR-030-500-080	.030	.76	.025	.64	.080	2.03	.500	12.70	.590	14.99	1.500
QMRR-030-250-100	.030	.76	.030	.76	.100	2.54	.250	6.35	.590	14.99	1.500
QMRR-030-500-100	.030	.76	.030	.76	.100	2.54	.500	12.70	.590	14.99	1.500
QMRR-030-750-100	.030	.76	.030	.76	.100	2.54	.750	19.05	1.090	27.67	2.000
QMRR-030-250-120	.030	.76	.040	1.02	.120	3.05	.250	6.35	.590	14.99	1.500
QMRR-030-500-120	.030	.76	.040	1.02	.120	3.05	.500	12.70	.590	14.99	1.500
QMRR-030-750-120	.030	.76	.040	1.02	.120	3.05	.750	19.05	1.090	27.67	2.000

Tolerances:
Groove Width: $+.002"(+.05\text{mm})-0"$
Shank Diameter:
 $-.0001"(-.0025\text{mm})-.0003"(-.0076\text{mm})$
Minimum Bore Diameter:
 $+.0005"(\pm .013\text{mm})$
Maximum Bore Depth:
 $+.030"(+0.76\text{mm})-0"$

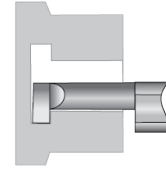
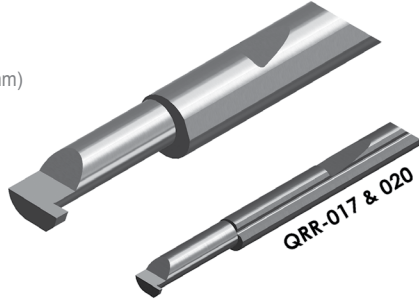

B

Page 274
for Coating
Info

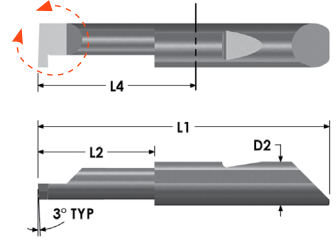
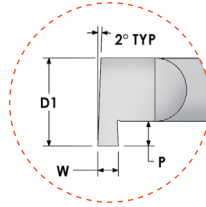

AITiN – Add “X” to the end of Catalog No.
Other sizes quoted upon request.

QRR Catalog No.	Groove Width (W)		Projection (P)		Minimum Bore Diameter (D1)		Maximum Bore Depth (L2)		Length From Holder (L4)		Overall Length (L1)
	inch	mm	inch	mm	inch	mm	inch	mm	inch	mm	
3/16" / 4.76mm Shanks – D2											
QRR-017-4	.017	.43	.030	.76	.180	4.57	.250	6.35	.590	14.99	1.500
QRR-017-6	.017	.43	.030	.76	.180	4.57	.375	9.52	.590	14.99	1.500
QRR-017-8	.017	.43	.030	.76	.180	4.57	.500	12.70	.590	14.99	1.500
QRR-017-10	.017	.43	.030	.76	.180	4.57	.625	15.88	1.090	27.67	2.000
QRR-020-4	.020	.51	.030	.76	.180	4.57	.250	6.35	.590	14.99	1.500
QRR-020-6	.020	.51	.030	.76	.180	4.57	.375	9.52	.590	14.99	1.500
QRR-020-8	.020	.51	.030	.76	.180	4.57	.500	12.70	.590	14.99	1.500
QRR-020-10	.020	.51	.030	.76	.180	4.57	.625	15.88	1.090	27.67	2.000
1/4" / 6.35mm Shanks – D2											
QRR-025-4	.025	.64	.050	1.27	.245	6.22	.250	6.35	.853	21.67	2.000
QRR-025-6	.025	.64	.050	1.27	.245	6.22	.375	9.52	.853	21.67	2.000
QRR-025-8	.025	.64	.050	1.27	.245	6.22	.500	12.70	.853	21.67	2.000
QRR-025-10	.025	.64	.050	1.27	.245	6.22	.625	15.88	.853	21.67	2.000
QRR-030-4	.030	.76	.050	1.27	.245	6.22	.250	6.35	.853	21.67	2.000
QRR-030-6	.030	.76	.050	1.27	.245	6.22	.375	9.52	.853	21.67	2.000
QRR-030-8	.030	.76	.050	1.27	.245	6.22	.500	12.70	.853	21.67	2.000
QRR-030-10	.030	.76	.050	1.27	.245	6.22	.625	15.88	.853	21.67	2.000
5/16" / 7.94mm Shanks – D2											
QRR-033-6	.033	.84	.100	2.54	.310	7.87	.375	9.52	.853	21.67	2.000
QRR-033-8	.033	.84	.100	2.54	.310	7.87	.500	12.70	.853	21.67	2.000
QRR-033-12	.033	.84	.100	2.54	.310	7.87	.750	19.05	.853	21.67	2.000
QRR-038-6	.038	.96	.100	2.54	.310	7.87	.375	9.52	.853	21.67	2.000
QRR-038-8	.038	.96	.100	2.54	.310	7.87	.500	12.70	.853	21.67	2.000
QRR-038-12	.038	.96	.100	2.54	.310	7.87	.750	19.05	.853	21.67	2.000

For current pricing and availability please visit our website at www.micro100.com

Tolerances:

Groove Width: $+ .002" (+.05mm) - 0"$

Shank Diameter:

$- .0001" (-.0025mm) - .0003" (-.0076mm)$

Minimum Bore Diameter:

$+ .0005" (\pm .013mm)$

Maximum Bore Depth:

$+ .030" (+0.76mm) - 0"$

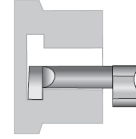
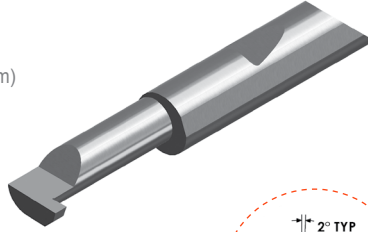

Page 274
for Coating
Info

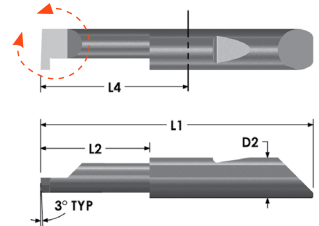
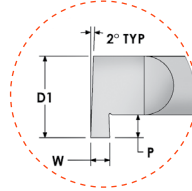

B

AITiN – Add "X" to the end of Catalog No.

Other sizes quoted upon request.

QRR Catalog No.	Groove Width (W)		Projection (P)		Minimum Bore Diameter (D1)		Maximum Bore Depth (L2)		Length From Holder (L4)		Overall Length (L1)
	inch	mm	inch	mm	inch	mm	inch	mm	inch	mm	inch
3/8" / 9.5mm Shanks – D2											
QRR-039-8	.039	.99	.100	2.54	.370	9.40	.500	12.70	.853	21.67	2.000
QRR-039-12	.039	.99	.100	2.54	.370	9.40	.750	19.05	.853	21.67	2.000
QRR-039-16	.039	.99	.100	2.54	.370	9.40	1.000	25.40	1.353	34.37	2.500
QRR-039-20	.039	.99	.100	2.54	.370	9.40	1.250	31.75	1.353	34.37	2.500
QRR-046-8	.046	1.17	.100	2.54	.370	9.40	.500	12.70	.853	21.67	2.000
QRR-046-12	.046	1.17	.100	2.54	.370	9.40	.750	19.05	.853	21.67	2.000
QRR-046-16	.046	1.17	.100	2.54	.370	9.40	1.000	25.40	1.353	34.37	2.500
QRR-046-20	.046	1.17	.100	2.54	.370	9.40	1.250	31.75	1.353	34.37	2.500
QRR-055-8	.055	1.40	.100	2.54	.370	9.40	.500	12.70	.853	21.67	2.000
QRR-055-12	.055	1.40	.100	2.54	.370	9.40	.750	19.05	.853	21.67	2.000
QRR-055-16	.055	1.40	.100	2.54	.370	9.40	1.000	25.40	1.353	34.37	2.500
QRR-055-20	.055	1.40	.100	2.54	.370	9.40	1.250	31.75	1.353	34.37	2.500
QRR-059-8	.059	1.50	.100	2.54	.370	9.40	.500	12.70	.853	21.67	2.000
QRR-059-12	.059	1.50	.100	2.54	.370	9.40	.750	19.05	.853	21.67	2.000
QRR-059-16	.059	1.50	.100	2.54	.370	9.40	1.000	25.40	1.353	34.37	2.500
QRR-059-20	.059	1.50	.100	2.54	.370	9.40	1.250	31.75	1.353	34.37	2.500
QRR-062-8	.062	1.57	.100	2.54	.370	9.40	.500	12.70	.853	21.67	2.000
QRR-062-12	.062	1.57	.100	2.54	.370	9.40	.750	19.05	.853	21.67	2.000
QRR-062-16	.062	1.57	.100	2.54	.370	9.40	1.000	25.40	1.353	34.37	2.500
QRR-062-20	.062	1.57	.100	2.54	.370	9.40	1.250	31.75	1.353	34.37	2.500
QRR-069-8	.069	1.75	.100	2.54	.370	9.40	.500	12.70	.853	21.67	2.000
QRR-069-12	.069	1.75	.100	2.54	.370	9.40	.750	19.05	.853	21.67	2.000
QRR-069-16	.069	1.75	.100	2.54	.370	9.40	1.000	25.40	1.353	34.37	2.500
QRR-069-20	.069	1.75	.100	2.54	.370	9.40	1.250	31.75	1.353	34.37	2.500
QRR-079-8	.079	2.01	.100	2.54	.370	9.40	.500	12.70	.853	21.67	2.000
QRR-079-12	.079	2.01	.100	2.54	.370	9.40	.750	19.05	.853	21.67	2.000
QRR-079-16	.079	2.01	.100	2.54	.370	9.40	1.000	25.40	1.353	34.37	2.500
QRR-079-20	.079	2.01	.100	2.54	.370	9.40	1.250	31.75	1.353	34.37	2.500
QRR-087-8	.087	2.21	.100	2.54	.370	9.40	.500	12.70	.853	21.67	2.000
QRR-087-12	.087	2.21	.100	2.54	.370	9.40	.750	19.05	.853	21.67	2.000
QRR-087-16	.087	2.21	.100	2.54	.370	9.40	1.000	25.40	1.353	34.37	2.500
QRR-087-20	.087	2.21	.100	2.54	.370	9.40	1.250	31.75	1.353	34.37	2.500

Tolerances:
Groove Width: $+.002"(+.05\text{mm})-0"$
Shank Diameter:
 $-.0001"(-.0025\text{mm})-.0003"(-.0076\text{mm})$
Minimum Bore Diameter:
 $+.0005"(\pm.013\text{mm})$
Maximum Bore Depth:
 $+.030"(+0.76\text{mm})-0"$

B

Page 274
for Coating
Info

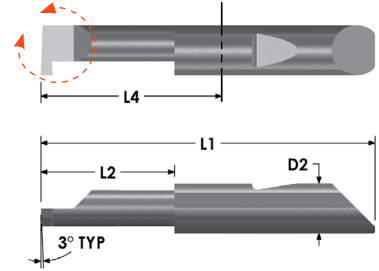
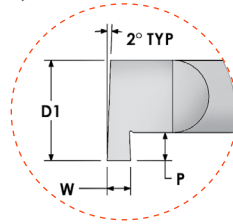
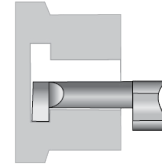
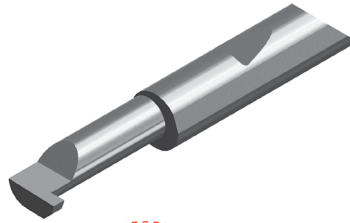

AITiN – Add "X" to the end of Catalog No.

Other sizes quoted upon request.

QRR Catalog No.	Groove Width (W)		Projection (P)		Minimum Bore Diameter (D1)		Maximum Bore Depth (L2)		Length From Holder (L4)		Overall Length (L1)
	inch	mm	inch	mm	inch	mm	inch	mm	inch	mm	inch
1/2" / 12.7mm Shanks – D2											
QRR-093-12	.093	2.36	.150	3.81	.495	12.57	.750	19.05	1.040	26.42	2.500
QRR-093-16	.093	2.36	.150	3.81	.495	12.57	1.000	25.40	1.040	26.42	2.500
QRR-093-20	.093	2.36	.150	3.81	.495	12.57	1.250	31.75	1.540	39.12	3.000
QRR-093-24	.093	2.36	.150	3.81	.495	12.57	1.500	38.10	1.540	39.12	3.000
QRR-118-12	.118	3.00	.150	3.81	.495	12.57	.750	19.05	1.040	26.42	2.500
QRR-118-16	.118	3.00	.150	3.81	.495	12.57	1.000	25.40	1.040	26.42	2.500
QRR-118-20	.118	3.00	.150	3.81	.495	12.57	1.250	31.75	1.540	39.12	3.000
QRR-118-24	.118	3.00	.150	3.81	.495	12.57	1.500	38.10	1.540	39.12	3.000
QRR-125-12	.125	3.18	.150	3.81	.495	12.57	.750	19.05	1.040	26.42	2.500
QRR-125-16	.125	3.18	.150	3.81	.495	12.57	1.000	25.40	1.040	26.42	2.500
QRR-125-20	.125	3.18	.150	3.81	.495	12.57	1.250	31.75	1.540	39.12	3.000
QRR-125-24	.125	3.18	.150	3.81	.495	12.57	1.500	38.10	1.540	39.12	3.000
QRR-156-12	.156	3.96	.150	3.81	.495	12.57	.750	19.05	1.040	26.42	2.500
QRR-156-16	.156	3.96	.150	3.81	.495	12.57	1.000	25.40	1.040	26.42	2.500
QRR-156-20	.156	3.96	.150	3.81	.495	12.57	1.250	31.75	1.540	39.12	3.000
QRR-156-24	.156	3.96	.150	3.81	.495	12.57	1.500	38.10	1.540	39.12	3.000
QRR-187-12	.187	4.75	.150	3.81	.495	12.57	.750	19.05	1.040	26.42	2.500
QRR-187-16	.187	4.75	.150	3.81	.495	12.57	1.000	25.40	1.040	26.42	2.500
QRR-187-20	.187	4.75	.150	3.81	.495	12.57	1.250	31.75	1.540	39.12	3.000
QRR-187-24	.187	4.75	.150	3.81	.495	12.57	1.500	38.10	1.540	39.12	3.000
QRR-236-12 ♦	.236	5.99	.150	3.81	.495	12.57	.750	19.05	1.040	26.42	2.500
QRR-236-16 ♦	.236	5.99	.150	3.81	.495	12.57	1.000	25.40	1.040	26.42	2.500
QRR-236-20 ♦	.236	5.99	.150	3.81	.495	12.57	1.250	31.75	1.540	39.12	3.000
QRR-236-24 ♦	.236	5.99	.150	3.81	.495	12.57	1.500	38.10	1.540	39.12	3.000
QRR-250-12 ♦	.250	6.35	.150	3.81	.495	12.57	.750	19.05	1.040	26.42	2.500
QRR-250-16 ♦	.250	6.35	.150	3.81	.495	12.57	1.000	25.40	1.040	26.42	2.500
QRR-250-20 ♦	.250	6.35	.150	3.81	.495	12.57	1.250	31.75	1.540	39.12	3.000
QRR-250-24 ♦	.250	6.35	.150	3.81	.495	12.57	1.500	38.10	1.540	39.12	3.000

♦ WHILE SUPPLIES LAST - Discontinued

Tolerances:

Groove Width: $+ .002" (+.05\text{mm}) - 0"$

Shank Diameter:

$- .0001" (-.0025\text{mm}) - .0003" (-.0076\text{mm})$

Minimum Bore Diameter:

$\pm .0005" (\pm .013\text{mm})$

Maximum Bore Depth:

$+ .030" (+0.76\text{mm}) - 0"$

Tool Radius:

1/2 of Dimension "W"

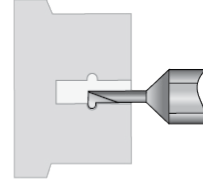
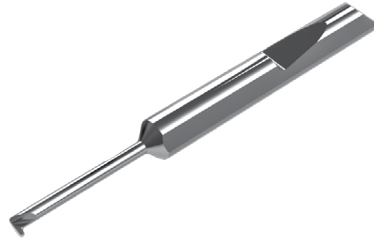

Page 274
for Coating
Info

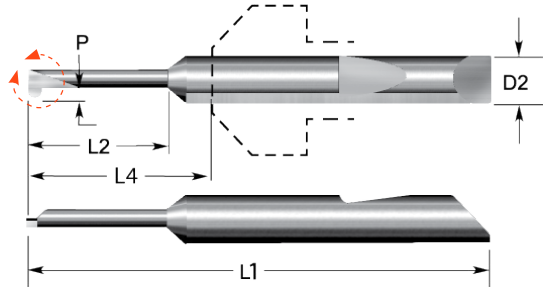
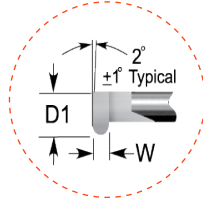

AITiN – Add "X" to the end of Catalog No.

Other sizes quoted upon request.

QMFR Catalog No.	Groove Width (W)		Projection (P)		Minimum Bore Diameter (D1)		Maximum Bore Depth (L2)		Length From Holder (L4)		Overall Length (L1)
	inch	mm	inch	mm	inch	mm	inch	mm	inch	mm	inch
3/16" / 4.8mm Shanks – D2											
QMFR-015-250-080	.015	.38	.025	0.64	.080	2.03	.250	6.35	.590	14.99	1.500
QMFR-015-375-080	.015	.38	.025	0.64	.080	2.03	.375	9.53	.590	14.99	1.500
QMFR-015-500-080	.015	.38	.025	0.64	.080	2.03	.500	12.70	.590	14.99	1.500
QMFR-015-250-100	.015	.38	.030	0.76	.100	2.54	.250	6.35	.590	14.99	1.500
QMFR-015-500-100	.015	.38	.030	0.76	.100	2.54	.500	12.70	.590	14.99	1.500
QMFR-015-750-100	.015	.38	.030	0.76	.100	2.54	.750	19.05	1.090	27.69	2.000
QMFR-020-250-080	.020	.51	.025	0.64	.080	2.03	.250	6.35	.590	14.99	1.500
QMFR-020-375-080	.020	.51	.025	0.64	.080	2.03	.375	9.53	.590	14.99	1.500
QMFR-020-500-080	.020	.51	.025	0.64	.080	2.03	.500	12.70	.590	14.99	1.500
QMFR-020-250-100	.020	.51	.030	0.76	.100	2.54	.250	6.35	.590	14.99	1.500
QMFR-020-500-100	.020	.51	.030	0.76	.100	2.54	.500	12.70	.590	14.99	1.500
QMFR-020-750-100	.020	.51	.030	0.76	.100	2.54	.750	19.05	1.090	27.69	2.000
QMFR-020-250-120	.020	.51	.040	1.02	.120	3.05	.250	6.35	.590	14.99	1.500
QMFR-020-500-120	.020	.51	.040	1.02	.120	3.05	.500	12.70	.590	14.99	1.500
QMFR-020-750-120	.020	.51	.040	1.02	.120	3.05	.750	19.05	1.090	27.69	2.000
QMFR-030-250-080	.030	.76	.025	0.64	.080	2.03	.250	6.35	.590	14.99	1.500
QMFR-030-375-080	.030	.76	.025	0.64	.080	2.03	.375	9.53	.590	14.99	1.500
QMFR-030-500-080	.030	.76	.025	0.64	.080	2.03	.500	12.70	.590	14.99	1.500
QMFR-030-250-100	.030	.76	.030	0.76	.100	2.54	.250	6.35	.590	14.99	1.500
QMFR-030-500-100	.030	.76	.030	0.76	.100	2.54	.500	12.70	.590	14.99	1.500
QMFR-030-750-100	.030	.76	.030	0.76	.100	2.54	.750	19.05	1.090	27.69	2.000
QMFR-030-250-120	.030	.76	.040	1.02	1.20	3.05	.250	6.35	.590	14.99	1.500
QMFR-030-500-120	.030	.76	.040	1.02	1.20	3.05	.500	12.70	.590	14.99	1.500
QMFR-030-750-120	.030	.76	.040	1.02	1.20	3.05	.750	19.05	1.090	27.69	2.000

For current pricing and availability please visit our website at www.micro100.com

Tolerances:

Groove Width: $+0.002" (+.05\text{mm})-0"$

Shank Diameter:

$-.0001" (-.0025\text{mm})-.0003" (-.0076\text{mm})$

Minimum Bore Diameter:

$\pm 0.0050" (\pm 0.13\text{mm})$

Maximum Bore Depth:

$+0.30" (+0.76\text{mm})-0"$

Tool Radius: 1/2 of Dimension "W"

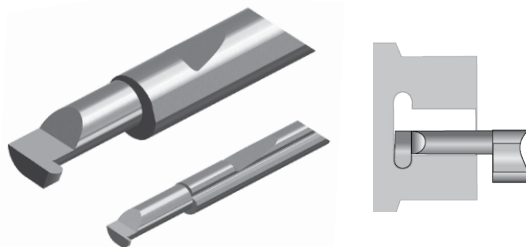

B

Page 274
for Coating
Info

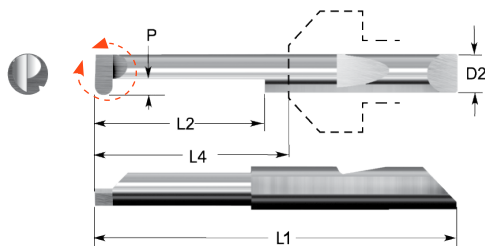
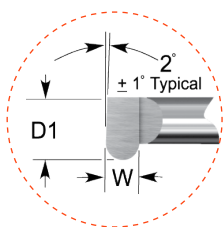

AITiN – Add "X" to the end of Catalog No.

Other sizes quoted upon request.

QFR Catalog No.	Groove Width (W)		Projection (P)		Minimum Bore Diameter (D1)		Maximum Bore Depth (L2)		Length From Holder (L4)		Overall Length (L1)
	inch	mm	inch	mm	inch	mm	inch	mm	inch	mm	inch
3/16" / 4.8mm Shanks – D2											
QFR-017-4	.017	.43	.030	.76	.180	4.57	.250	6.35	.590	14.99	1.500
QFR-017-6	.017	.43	.030	.76	.180	4.57	.375	9.53	.590	14.99	1.500
QFR-017-8	.017	.43	.030	.76	.180	4.57	.500	12.70	.590	14.99	1.500
QFR-017-10	.017	.43	.030	.76	.180	4.57	.625	15.88	1.090	27.69	2.000
QFR-020-4	.020	.51	.030	.76	.180	4.57	.250	6.35	.590	14.99	1.500
QFR-020-6	.020	.51	.030	.76	.180	4.57	.375	9.53	.590	14.99	1.500
QFR-020-8	.020	.51	.030	.76	.180	4.57	.500	12.70	.590	14.99	1.500
QFR-020-10	.020	.51	.030	.76	.180	4.57	.625	15.88	1.090	27.69	2.000
1/4" / 6.4mm Shanks – D2											
QFR-025-4	.025	.64	.050	1.27	.245	6.22	.250	6.35	1.090	27.69	2.000
QFR-025-6	.025	.64	.050	1.27	.245	6.22	.375	9.53	1.090	27.69	2.000
QFR-025-8	.025	.64	.050	1.27	.245	6.22	.500	12.70	1.090	27.69	2.000
QFR-025-10	.025	.64	.050	1.27	.245	6.22	.625	15.88	1.090	27.69	2.000
QFR-030-4	.030	.76	.050	1.27	.245	6.22	.250	6.35	1.090	27.69	2.000
QFR-030-6	.030	.76	.050	1.27	.245	6.22	.375	9.53	1.090	27.69	2.000
QFR-030-8	.030	.76	.050	1.27	.245	6.22	.500	12.70	1.090	27.69	2.000
QFR-030-10	.030	.76	.050	1.27	.245	6.22	.625	15.88	1.090	27.69	2.000
5/16" / 7.9mm Shanks – D2											
QFR-033-6	.033	.84	.100	2.54	.310	7.87	.375	9.53	1.090	27.69	2.000
QFR-033-8	.033	.84	.100	2.54	.310	7.87	.500	12.70	1.090	27.69	2.000
QFR-033-12	.033	.84	.100	2.54	.310	7.87	.750	19.05	1.090	27.69	2.000
QFR-038-6	.038	.97	.100	2.54	.310	7.87	.375	9.53	1.090	27.69	2.000
QFR-038-8	.038	.97	.100	2.54	.310	7.87	.500	12.70	1.090	27.69	2.000
QFR-038-12	.038	.97	.100	2.54	.310	7.87	.750	19.05	1.090	27.69	2.000

For current pricing and availability please visit our website at www.micro100.com

Tolerances:

Groove Width: $+.002(+.05\text{mm})-0"$

Shank Diameter:

$-.0001(-.0025\text{mm})-.0003(-.0076\text{mm})$

Minimum Bore Diameter:

$\pm .0050(\pm .013\text{mm})$

Maximum Bore Depth:

$+.030(+0.76\text{mm})-0"$

Tool Radius: 1/2 of Dimension "W"

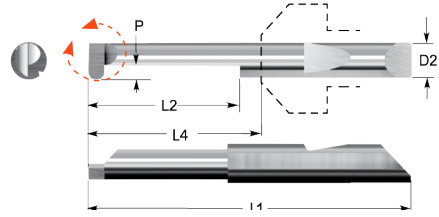
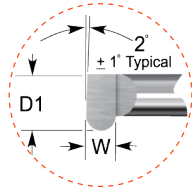
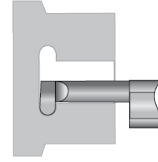
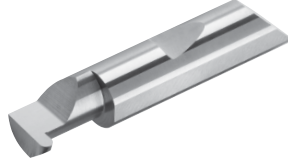

AITiN – Add "X" to the end of Catalog No.

Other sizes quoted upon request.

QFR Catalog No.	Groove Width (W)		Projection (P)		Minimum Bore Diameter (D1)		Maximum Bore Depth (L2)		Length From Holder (L4)		Overall Length (L1)
	inch	mm	inch	mm	inch	mm	inch	mm	inch	mm	inch
3/8" / 9.5mm Shanks – D2											
QFR-039-8	.039	1.00	.100	2.54	.370	9.40	.500	12.70	.853	21.67	2.000
QFR-039-12	.039	1.00	.100	2.54	.370	9.40	.750	19.05	.853	21.67	2.000
QFR-039-16	.039	1.00	.100	2.54	.370	9.40	1.000	25.40	1.353	34.37	2.500
QFR-039-20	.039	1.00	.100	2.54	.370	9.40	1.250	31.75	1.353	34.37	2.500
QFR-046-8	.046	1.17	.100	2.54	.370	9.40	.500	12.70	.853	21.67	2.000
QFR-046-12	.046	1.17	.100	2.54	.370	9.40	.750	19.05	.853	21.67	2.000
QFR-046-16	.046	1.17	.100	2.54	.370	9.40	1.000	25.40	1.353	34.37	2.500
QFR-046-20	.046	1.17	.100	2.54	.370	9.40	1.250	31.75	1.353	34.37	2.500
QFR-055-8	.055	1.40	.100	2.54	.370	9.40	.500	12.70	.853	21.67	2.000
QFR-055-12	.055	1.40	.100	2.54	.370	9.40	.750	19.05	.853	21.67	2.000
QFR-055-16	.055	1.40	.100	2.54	.370	9.40	1.000	25.40	1.353	34.37	2.500
QFR-055-20	.055	1.40	.100	2.54	.370	9.40	1.250	31.75	1.353	34.37	2.500
QFR-059-8	.059	1.50	.100	2.54	.370	9.40	.500	12.70	.853	21.67	2.000
QFR-059-12	.059	1.50	.100	2.54	.370	9.40	.750	19.05	.853	21.67	2.000
QFR-059-16	.059	1.50	.100	2.54	.370	9.40	1.000	25.40	1.353	34.37	2.500
QFR-059-20	.059	1.50	.100	2.54	.370	9.40	1.250	31.75	1.353	34.37	2.500
QFR-062-8	.062	1.57	.100	2.54	.370	9.40	.500	12.70	.853	21.67	2.000
QFR-062-12	.062	1.57	.100	2.54	.370	9.40	.750	19.05	.853	21.67	2.000
QFR-062-16	.062	1.57	.100	2.54	.370	9.40	1.000	25.40	1.353	34.37	2.500
QFR-062-20	.062	1.57	.100	2.54	.370	9.40	1.250	31.75	1.353	34.37	2.500
QFR-069-8	.069	1.75	.100	2.54	.370	9.40	.500	12.70	.853	21.67	2.000
QFR-069-12	.069	1.75	.100	2.54	.370	9.40	.750	19.05	.853	21.67	2.000
QFR-069-16	.069	1.75	.100	2.54	.370	9.40	1.000	25.40	1.353	34.37	2.500
QFR-069-20	.069	1.75	.100	2.54	.370	9.40	1.250	31.75	1.353	34.37	2.500
QFR-079-8	.079	2.00	.100	2.54	.370	9.40	.500	12.70	.853	21.67	2.000
QFR-079-12	.079	2.00	.100	2.54	.370	9.40	.750	19.05	.853	21.67	2.000
QFR-079-16	.079	2.00	.100	2.54	.370	9.40	1.000	25.40	1.353	34.37	2.500
QFR-079-20	.079	2.00	.100	2.54	.370	9.40	1.250	31.75	1.353	34.37	2.500
QFR-087-8	.087	2.21	.100	2.54	.370	9.40	.500	12.70	.853	21.67	2.000
QFR-087-12	.087	2.21	.100	2.54	.370	9.40	.750	19.05	.853	21.67	2.000
QFR-087-16	.087	2.21	.100	2.54	.370	9.40	1.000	25.40	1.353	34.37	2.500
QFR-087-20	.087	2.21	.100	2.54	.370	9.40	1.250	31.75	1.353	34.37	2.500

Tolerances:

Groove Width: $+0.002$ "- $(+.05\text{mm})$ - 0 "

Shank Diameter:

$-.0001$ "- $(-.0025\text{mm})$ - $.0003$ "- $(-.0076\text{mm})$

Minimum Bore Diameter:

± 0.0005 " $(\pm 0.13\text{mm})$

Maximum Bore Depth:

$+0.030$ " $(+0.76\text{mm})$ - 0 "

Tool Radius: $1/2$ of Dimension "W"

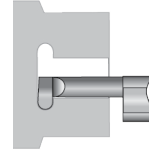
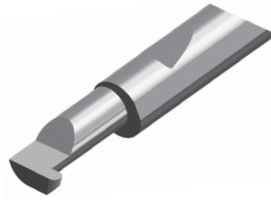

B

Page 274
for Coating
Info

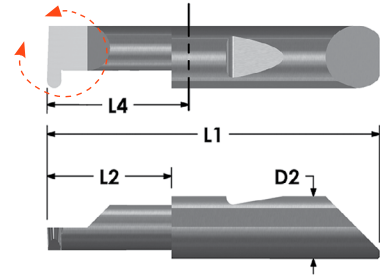
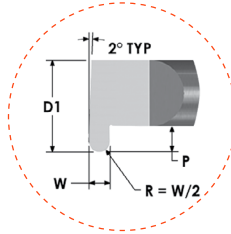

AITIN – Add "X" to the end of Catalog No.
Other sizes quoted upon request.

QFR Catalog No.	Groove Width (W)		Projection (P)		Minimum Bore Diameter (D1)		Maximum Bore Depth (L2)		Length From Holder (L4)		Overall Length (L1)
	inch	mm	inch	mm	inch	mm	inch	mm	inch	mm	inch
1/2" / 12.7mm Shanks – D2											
QFR-093-12	.093	2.36	.150	3.81	.495	12.57	.750	19.05	1.040	26.42	2.500
QFR-093-16	.093	2.36	.150	3.81	.495	12.57	1.000	25.40	1.040	26.42	2.500
QFR-093-20	.093	2.36	.150	3.81	.495	12.57	1.250	31.75	1.540	39.12	3.000
QFR-093-24	.093	2.36	.150	3.81	.495	12.57	1.500	38.10	1.540	39.12	3.000
QFR-118-12	.118	3.00	.150	3.81	.495	12.57	.750	19.05	1.040	26.42	2.500
QFR-118-16	.118	3.00	.150	3.81	.495	12.57	1.000	25.40	1.040	26.42	2.500
QFR-118-20	.118	3.00	.150	3.81	.495	12.57	1.250	31.75	1.540	39.12	3.000
QFR-118-24	.118	3.00	.150	3.81	.495	12.57	1.500	38.10	1.540	39.12	3.000
QFR-125-12	.125	3.18	.150	3.81	.495	12.57	.750	19.05	1.040	26.42	2.500
QFR-125-16	.125	3.18	.150	3.81	.495	12.57	1.000	25.40	1.040	26.42	2.500
QFR-125-20	.125	3.18	.150	3.81	.495	12.57	1.250	31.75	1.540	39.12	3.000
QFR-125-24	.125	3.18	.150	3.81	.495	12.57	1.500	38.10	1.540	39.12	3.000
QFR-156-12 ♦	.156	3.96	.150	3.81	.495	12.57	.750	19.05	1.040	26.42	2.500
QFR-156-16 ♦	.156	3.96	.150	3.81	.495	12.57	1.000	25.40	1.040	26.42	2.500
QFR-156-20 ♦	.156	3.96	.150	3.81	.495	12.57	1.250	31.75	1.540	39.12	3.000
QFR-156-24 ♦	.156	3.96	.150	3.81	.495	12.57	1.500	38.10	1.540	39.12	3.000
QFR-187-12 ♦	.187	4.75	.150	3.81	.495	12.57	.750	19.05	1.040	26.42	2.500
QFR-187-16 ♦	.187	4.75	.150	3.81	.495	12.57	1.000	25.40	1.040	26.42	2.500
QFR-187-20 ♦	.187	4.75	.150	3.81	.495	12.57	1.250	31.75	1.540	39.12	3.000
QFR-187-24 ♦	.187	4.75	.150	3.81	.495	12.57	1.500	38.10	1.540	39.12	3.000
QFR-236-12 ♦	.236	6.00	.150	3.81	.495	12.57	.750	19.05	1.040	26.42	2.500
QFR-236-16 ♦	.236	6.00	.150	3.81	.495	12.57	1.000	25.40	1.040	26.42	2.500
QFR-236-20 ♦	.236	6.00	.150	3.81	.495	12.57	1.250	31.75	1.540	39.12	3.000
QFR-236-24 ♦	.236	6.00	.150	3.81	.495	12.57	1.500	38.10	1.540	39.12	3.000
QFR-250-12 ♦	.250	6.35	.150	3.81	.495	12.57	.750	19.05	1.040	26.42	2.500
QFR-250-16 ♦	.250	6.35	.150	3.81	.495	12.57	1.000	25.40	1.040	26.42	2.500
QFR-250-20 ♦	.250	6.35	.150	3.81	.495	12.57	1.250	31.75	1.540	39.12	3.000
QFR-250-24 ♦	.250	6.35	.150	3.81	.495	12.57	1.500	38.10	1.540	39.12	3.000

♦ WHILE SUPPLIES LAST - Discontinued

Tolerances:
Groove Width:
+.002"(+.05mm)-0"
Shank Diameter:
-.0001"(-.0025mm)-.0003"(-.0076mm)
Projection: +.030"(+0.76mm)-0"

Page 274
for Coating
Info

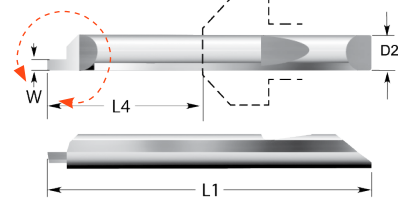
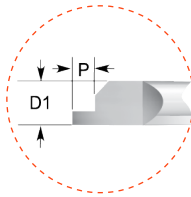
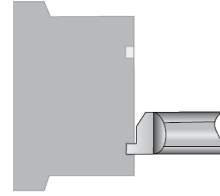
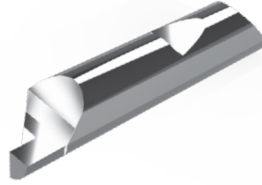

AITiN – Add "X" to the end of Catalog No.

Other sizes quoted upon request.

QFG Catalog No.	Groove Width (W)		Projection (P)		Minimum Groove Diameter (D1)		Length From Holder (L4)		Overall Length (L1)
	inch	mm	inch	mm	inch	mm	inch	mm	inch
3/16" / 4.8mm Shanks – D2									
QFG-180-020	.020	0.51	.050	1.27	.190	1.27	.590	14.99	1.500
QFG-180-030	.030	0.76	.050	1.27	.190	1.27	.590	14.99	1.500
1/4" / 6.4mm Shanks – D2									
QFG-230-020	.020	0.51	.050	1.27	.240	5.99	.853	21.67	2.000
QFG-230-030	.030	0.76	.050	1.27	.240	5.99	.853	21.67	2.000
QFG-250-020	.020	0.51	.050	1.27	.260	5.99	.853	21.67	2.000
QFG-250-030	.030	0.76	.050	1.27	.260	5.99	.853	21.67	2.000
5/16" / 7.9mm Shanks – D2									
QFG-312-030	.030	0.76	.050	1.27	.322	8.18	.853	21.67	2.000
QFG-312-040	.040	1.02	.050	1.27	.322	8.18	.853	21.67	2.000
QFG-312-062	.062	1.57	.100	2.54	.322	8.18	.853	21.67	2.000
3/8" / 9.5mm Shanks – D2									
QFG-375-062	.062	1.57	.100	2.54	.385	9.78	.853	21.67	2.000
QFG-375-078	.078	1.98	.100	2.54	.385	9.78	.853	21.67	2.000
QFG-375-093	.093	2.36	.100	2.54	.385	9.78	.853	21.67	2.000
QFG-375-118	.118	3.00	.150	3.81	.385	9.78	.853	21.67	2.000
QFG-375-125	.125	3.18	.150	3.81	.385	9.78	.853	21.67	2.000
1/2" / 12.7mm Shanks – D2									
QFG-470-062	.062	1.57	.100	2.54	.480	12.00	1.040	26.42	2.500
QFG-470-078	.078	1.98	.100	2.54	.480	12.00	1.040	26.42	2.500
QFG-470-093	.093	2.36	.100	2.54	.480	12.00	1.040	26.42	2.500
QFG-470-118	.118	3.00	.150	3.81	.480	12.00	1.040	26.42	2.500
QFG-470-125	.125	3.18	.150	3.81	.480	12.00	1.040	26.42	2.500
QFG-470-156	.156	3.96	.150	3.81	.480	12.00	1.040	26.42	2.500
QFG-490-062	.062	1.57	.100	2.54	.500	12.70	1.040	26.42	2.500
QFG-490-078	.078	1.98	.100	2.54	.500	12.70	1.040	26.42	2.500
QFG-490-093	.093	2.36	.100	2.54	.500	12.70	1.040	26.42	2.500
QFG-490-118	.118	3.00	.150	3.81	.500	12.70	1.040	26.42	2.500
QFG-490-125	.125	3.18	.150	3.81	.500	12.70	1.040	26.42	2.500
QFG-490-156	.156	3.96	.150	3.81	.500	12.70	1.040	26.42	2.500

Tolerances:

Shank Diameter:
-.0001"(-.0025mm)-.0003"(-.0076mm)
Minimum Bore Diameter:
±.0005"(±.01mm)
Maximum Bore Depth:
+.030"(+0.76mm)0"
Tool Radius:
.002"(.05mm)±.001"(±.03mm)

B

Page 274
for Coating
Info

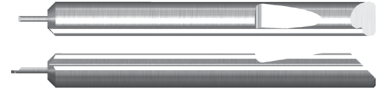
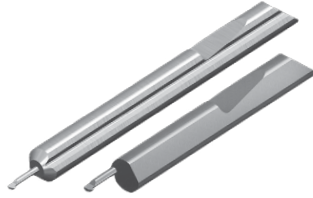

QIT-035 THRU 050

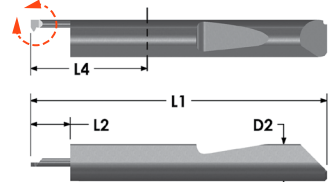
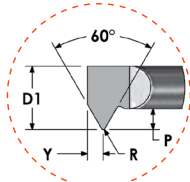

QIT-060 THRU 120

Tool Radius:
.002"(.05mm)±.001"(±.03mm)

AITIN – Add "X" to the end of Catalog No.
Other sizes quoted upon request.

QIT Catalog No.	UN Threads *(T.P.I.)		Metric Threads *(Pitch)		Minimum Bore Diameter (D1)		Projection (P)		Maximum Bore Depth (L2)		Offset Point (Y)		Length From Holder (L4)		Overall Length (L1)
	inch	mm	inch	mm	inch	mm	inch	mm	inch	mm	inch	mm	inch	mm	inch
	3/16" / 4.8mm Shanks – D2														
QIT-035075	56 to 80	.45 to .32	.035	.89	.015	.38	.075	1.91	.008	.20	.590	14.9	1.500		
QIT-035100	56 to 80	.45 to .32	.035	.89	.015	.38	.100	2.54	.008	.20	.590	14.9	1.500		
QIT-035150	56 to 80	.45 to .32	.035	.89	.015	.38	.150	3.81	.008	.20	.590	14.9	1.500		
QIT-040075	56 to 80	.45 to .32	.040	1.02	.020	.51	.075	1.91	.009	.23	.590	14.9	1.500		
QIT-040100	56 to 80	.45 to .32	.040	1.02	.020	.51	.100	2.54	.009	.23	.590	14.9	1.500		
QIT-040150	56 to 80	.45 to .32	.040	1.02	.020	.51	.150	3.81	.009	.23	.590	14.9	1.500		
QIT-050100	48 to 80	.53 to .32	.050	1.27	.020	.51	.100	2.54	.012	.30	.590	14.9	1.500		
QIT-050150	48 to 80	.53 to .32	.050	1.27	.020	.51	.150	3.81	.012	.30	.590	14.9	1.500		
QIT-050200	48 to 80	.53 to .32	.050	1.27	.020	.51	.200	5.08	.012	.30	.590	14.9	1.500		
QIT-060200	40 to 80	.64 to .32	.060	1.52	.020	.51	.200	5.08	.012	.30	.590	14.9	1.500		
QIT-060300	40 to 80	.64 to .32	.060	1.52	.020	.51	.300	7.62	.012	.30	.590	14.9	1.500		
QIT-080250	32 to 76	.79 to .33	.080	2.03	.020	.51	.250	6.35	.012	.30	.590	14.9	1.500		
QIT-080350	32 to 76	.79 to .33	.080	2.03	.020	.51	.350	8.89	.012	.30	.590	14.9	1.500		
QIT-080500	32 to 76	.79 to .33	.080	2.03	.020	.51	.500	12.70	.012	.30	.590	14.9	1.500		
QIT-100250	32 to 64	.79 to .40	.100	2.54	.025	.64	.250	6.35	.014	.36	.590	14.9	1.500		
QIT-100350	32 to 64	.79 to .40	.100	2.54	.025	.64	.350	8.89	.014	.36	.590	14.9	1.500		
QIT-100500	32 to 64	.79 to .40	.100	2.54	.025	.64	.500	12.70	.014	.36	.590	14.9	1.500		
QIT-100600	32 to 64	.79 to .40	.100	2.54	.025	.64	.600	15.24	.014	.36	1.090	27.7	2.000		
QIT-110250	32 to 64	.79 to .40	.110	2.79	.030	.76	.250	6.35	.016	.41	.590	14.9	1.500		
QIT-110400	32 to 64	.79 to .40	.110	2.79	.030	.76	.400	10.16	.016	.41	.590	14.9	1.500		
QIT-110600	32 to 64	.79 to .40	.110	2.79	.030	.76	.600	15.24	.016	.41	1.090	27.7	2.000		
QIT-110700	32 to 64	.79 to .40	.110	2.79	.030	.76	.700	17.78	.016	.41	1.090	27.7	2.000		
QIT-120250	24 to 56	1.06 to .45	.120	3.05	.030	.76	.250	6.35	.017	.43	.590	14.9	1.500		
QIT-120500	24 to 56	1.06 to .45	.120	3.05	.030	.76	.500	12.70	.017	.43	.590	14.9	1.500		
QIT-120600	24 to 56	1.06 to .45	.120	3.05	.030	.76	.600	15.24	.017	.43	1.090	27.7	2.000		
QIT-120750	24 to 56	1.06 to .45	.120	3.05	.030	.76	.700	19.05	.017	.43	1.090	27.7	2.000		

*Thread ranges are based on height of sharp thread (.866P) and Projection.

Tolerances:

Shank Diameter:

- .0001" (-.0025mm) - .0003" (-.0076mm)

Minimum Bore Diameter:

± .0005" (±.01mm)

Maximum Bore Depth:

+ .030" (+0.76mm) 0"

Tool Radius:

.002" (.05mm) ± .001" (±.03mm)

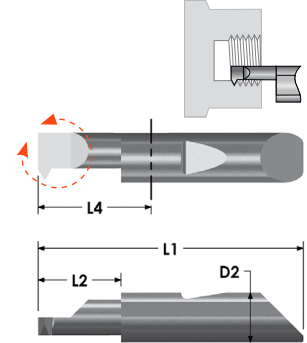
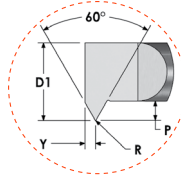
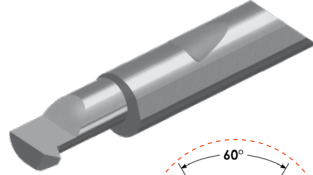

B

AITiN – Add “X” to the end of Catalog No.

Other sizes quoted upon request.

Tool Radius:
.002" (.05mm) ± .001" (±.03mm)

QIT Catalog No.	UN Threads	Metric Threads	Minimum Bore Diameter (D1)		Projection (P)		Maximum Bore Depth (L2)		Offset Point (Y)		Length From Holder (L4)		Overall Length (L1)
	*(T.P.I.)	*(Pitch)	inch	mm	inch	mm	inch	mm	inch	mm	inch	mm	inch
3/16" / 4.8mm Shanks – D2													
QIT-140250	20 To 56	1.27 To .096	.140	3.56	.015	.38	.250	6.35	.020	.51	.590	14.9	1.500
QIT-140400	20 To 56	1.27 To .096	.140	3.56	.015	.38	.400	10.16	.020	.51	.590	14.9	1.500
QIT-140500	20 To 56	1.27 To .096	.140	3.56	.015	.38	.500	12.70	.020	.51	.590	14.9	1.500
QIT-140750	20 To 56	1.27 To .096	.140	3.56	.020	.51	.750	19.05	.020	.51	.590	14.9	2.000
QIT-160250	20 To 56	1.27 To .096	.160	4.06	.020	.51	.250	6.35	.023	.58	.590	14.9	1.500
QIT-160400	20 To 56	1.27 To .096	.160	4.06	.020	.51	.400	10.16	.023	.58	.590	14.9	1.500
QIT-160500	20 To 56	1.27 To .096	.160	4.06	.020	.51	.500	12.70	.023	.58	.590	14.9	1.500
QIT-160750	20 To 56	1.27 To .096	.160	4.06	.020	.51	.750	19.05	.023	.58	1.090	27.7	2.000
QIT-1601000	20 To 56	1.27 To .096	.160	4.06	.020	.51	1.000	25.40	.023	.58	1.090	27.7	2.000
1/4" / 6.4mm Shanks – D2													
QIT-180350	18 To 56	1.41 To .096	.180	4.57	.020	.51	.350	8.89	.023	.58	.853	21.7	2.000
QIT-180500	18 To 56	1.41 To .096	.180	4.57	.020	.51	.500	12.70	.023	.58	.853	21.7	2.000
QIT-180750	18 To 56	1.41 To .096	.180	4.57	.020	.51	.750	19.05	.023	.58	.853	21.7	2.000
QIT-1801000	18 To 56	1.41 To .096	.180	4.57	.020	.51	1.000	25.40	.023	.58	1.353	34.4	2.500
QIT-200400	16 To 40	1.41 To .096	.200	5.08	.020	.51	.350	8.89	.026	.66	.853	21.7	2.000
QIT-200600	16 To 40	1.41 To .096	.200	5.08	.020	.51	.600	15.20	.026	.66	.853	21.7	2.000
QIT-200750	16 To 40	1.41 To .096	.200	5.08	.025	.64	.750	19.05	.026	.66	.853	21.7	2.000
QIT-2001000	16 To 40	1.41 To .096	.200	5.08	.025	.64	1.000	25.40	.026	.66	1.353	34.4	2.500
5/16" / 7.9mm Shanks – D2													
QIT-230400	14 To 40	1.81 To .096	.230	5.84	.025	.64	.400	10.16	.032	.81	.853	21.7	2.000
QIT-230500	14 To 40	1.81 To .096	.230	5.84	.025	.64	.500	10.16	.032	.81	.853	21.7	2.000
QIT-230600	14 To 40	1.81 To .096	.230	5.84	.030	.76	.600	15.24	.032	.81	.853	21.7	2.000
QIT-230750	14 To 40	1.81 To .096	.230	5.84	.030	.76	.750	19.05	.032	.81	.853	21.7	2.000
QIT-2301000	14 To 40	1.81 To .096	.230	5.84	.030	.76	1.000	25.40	.032	.81	1.353	34.4	2.500
QIT-2301500	14 To 40	1.81 To .096	.230	5.84	.030	.76	1.500	38.10	.032	.81	1.856	47.1	3.000
QIT-290500	12 To 40	1.81 To 2.17	.290	7.37	.030	.76	.400	10.16	.040	1.02	.853	21.7	2.000
QIT-290750	12 To 40	1.81 To 2.17	.290	7.37	.030	.76	.600	15.24	.040	1.02	.853	21.7	2.000
QIT-2901000	12 To 40	1.81 To 2.17	.290	7.37	.030	.76	.750	19.05	.040	1.02	1.353	34.4	2.500
QIT-2901250	12 To 40	1.81 To 2.17	.290	7.37	.030	.76	1.000	25.40	.040	1.02	1.353	34.4	2.500
QIT-2901750	12 To 40	1.81 To 2.17	.290	7.37	.030	.76	1.750	44.50	.040	1.02	1.856	47.1	3.000

*Thread ranges are based on height of sharp thread (.866P) and Projection.

Tolerances:

Shank Diameter:
-.0001"(-.0025mm)-.0003"(-.0076mm)
Minimum Bore Diameter:
±.0005"(±.01mm)
Maximum Drill Depth:
(+.030"/-0") (+.76mm/-0)

B

Page 274
for Coating
Info

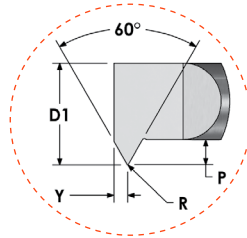
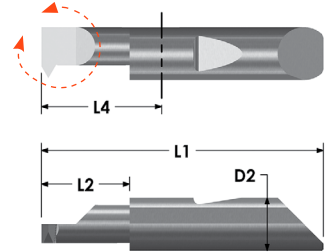
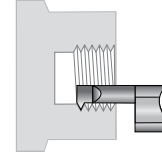
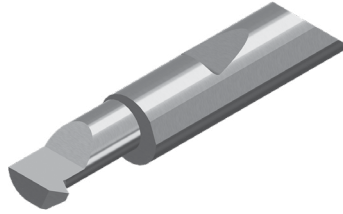

Tool Radius:

.002"(.05mm)±.001"(±.03mm)

AITiN – Add "X" to the end of Catalog No.

Other sizes quoted upon request.

QIT Catalog No.	UN Threads	Metric Threads	Minimum Bore Diameter (D1)		Projection (P)		Maximum Bore Depth (L2)		Offset Point (Y)		Length From Holder (L4)		Overall Length (L1)
	*(T.P.I.)	*(Pitch)	inch	mm	inch	mm	inch	mm	inch	mm	inch	mm	inch
	inch	mm	inch	mm	inch	mm	inch	mm	inch	mm	inch	mm	inch
3/8" / 9.5mm Shanks – D2													
QIT-320500	10 TO 32	2.12 TO .79	.320	8.13	.075	1.91	.500	12.70	.049	1.24	.853	21.67	2.000
QIT-320750	10 TO 32	2.12 TO .79	.320	8.13	.075	1.91	.750	19.05	.049	1.24	.853	21.67	2.000
QIT-3201000	10 TO 32	2.12 TO .79	.320	8.13	.075	1.91	1.000	25.40	.049	1.24	1.353	34.37	2.500
QIT-3201250	10 TO 32	2.12 TO .79	.320	8.13	.075	1.91	1.250	31.75	.049	1.24	1.353	34.37	2.500
QIT-3201800	10 TO 32	2.12 TO .79	.320	8.13	.075	1.91	1.800	45.72	.049	1.24	1.853	47.07	3.000
QIT-360500	10 TO 32	2.54 TO .79	.360	9.14	.085	2.16	.500	12.70	.055	1.40	.853	21.67	2.000
QIT-360750	10 TO 32	2.54 TO .79	.360	9.14	.085	2.16	.750	19.05	.055	1.40	.853	21.67	2.000
QIT-3601000	10 TO 32	2.54 TO .79	.360	9.14	.085	2.16	1.000	25.40	.055	1.40	1.353	34.37	2.500
QIT-3601250	10 TO 32	2.54 TO .79	.360	9.14	.085	2.16	1.250	31.75	.055	1.40	1.353	34.37	2.500
QIT-3601800	10 TO 32	2.54 TO .79	.360	9.14	.085	2.16	1.800	45.72	.055	1.40	1.853	47.07	3.000
1/2" / 12.7mm Shanks – D2													
QIT-460750	6 TO 24	3.18 TO 1.06	.460	11.68	.120	3.05	.750	19.05	.078	1.98	1.040	26.42	2.500
QIT-4601500	6 TO 24	3.18 TO 1.06	.460	11.68	.120	3.05	1.500	38.10	.078	1.98	1.540	39.12	3.000
QIT-4602000	6 TO 24	3.18 TO 1.06	.460	11.68	.120	3.05	2.000	50.80	.078	1.98	2.040	51.82	3.500
QIT-490750	6 TO 24	3.18 TO 1.06	.490	12.45	.120	3.05	.750	19.05	.078	1.98	1.040	26.42	2.500
QIT-4901500	6 TO 24	3.18 TO 1.06	.490	12.45	.120	3.05	1.500	38.10	.078	1.98	1.540	39.12	3.000
QIT-4902000	6 TO 24	3.18 TO 1.06	.490	12.45	.120	3.05	2.000	50.80	.078	1.98	2.040	51.82	3.500

Thread ranges are based on height of sharp thread (.866P) and Projection.

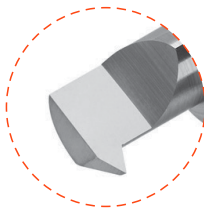

Tolerances:

Shank Diameter:

$-.0001"(-.0025mm)-.0003"(-.0076mm)$

Drill Diameter:

$+0/-.0005"(+0/- .127mm)$

Maximum Drill Depth:

$(+.030"/-0") (+.76mm/-0)$

**Thinned Web
Reduces
"Walking"**

**Page 274
for Coating
Info**

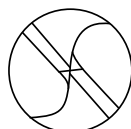

Style 2



Style 1

Point Geometry
Designed for
Self-Centering

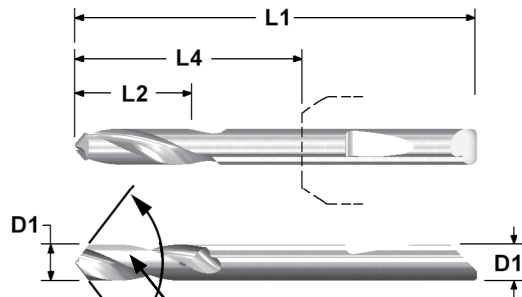
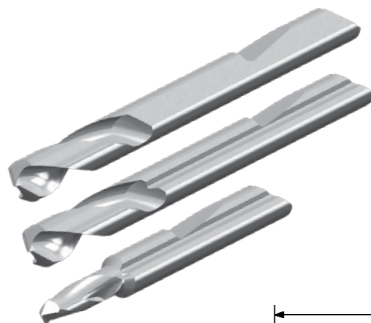

90°/120°/140°
Included Point Angles

**Diameter D1 is not relieved to drill.

AITiN – Add "X" to the end of Catalog No.
Other sizes quoted upon request.

QSPD Catalog No.			Style Number	Cutter Diameter (D1)		Max Drill Depth (Flute) (L2)		Length From Holder (L4)		Overall Length (L1)
90° Included Angle	120° Included Angle	140° Included Angle		inch	mm	inch	mm	inch	mm	inch
3/16" / 4.8mm Shanks – D2										
–	QSPD-015-120 ♦	QSPD-015-140 ♦	1	.015	0.38	.045	1.14	.590	14.99	1.500
QSPD-020-090 ♦	QSPD-020-120 ♦	QSPD-020-140 ♦	1	.020	0.51	.060	1.52	.590	14.99	1.500
QSPD-025-090 ♦	QSPD-025-120 ♦	QSPD-025-140 ♦	1	.025	0.64	.075	1.91	.590	14.99	1.500
QSPD-030-090 ♦	QSPD-030-120 ♦	QSPD-030-140 ♦	1	.030	0.76	.090	2.29	.590	14.99	1.500
QSPD-035-090 ♦	QSPD-035-120 ♦	QSPD-035-140 ♦	1	.035	0.89	.105	2.67	.590	14.99	1.500
QSPD-040-090	QSPD-040-120 ♦	QSPD-040-140 ♦	1	.0400	1.02	.120	3.05	.590	14.99	1.500
QSPD-060-090	QSPD-060-120	QSPD-060-140	1	.0600	1.52	.180	4.57	.590	14.99	1.500
QSPD-090-090	QSPD-090-120	QSPD-090-140	1	.0900	2.29	.270	6.86	.590	14.99	1.500
QSPD-118-090	QSPD-118-120	QSPD-118-140	1	.1181	3.00	.354	8.99	.590	14.99	1.500
QSPD-125-090	QSPD-125-120	QSPD-125-140	1	.1250	3.18	.375	9.53	.590	14.99	1.500
QSPD-187-090	QSPD-187-120	QSPD-187-140	2	.1875	4.76	.625	15.88	1.090	27.69	2.000
1/4" / 6.4mm Shanks – D2										
QSPD-250-090	QSPD-250-120	QSPD-250-140	2	.2500	6.35	.750	19.05	1.090	27.69	2.500
3/8" / 9.5mm Shanks – D2										
QSPD-375-090	QSPD-375-120	QSPD-375-140	2	.3750	9.53	1.000	25.40	1.090	27.69	2.500

♦ WHILE SUPPLIES LAST - Discontinued

For current pricing and availability please visit our website at www.micro100.com

Tolerances:

Shank Diameter:
-.0001"(-.0025mm)/-
.0003"(-.0076mm)
Tip Diameter: +0"/-
.003"(+0/-0.08mm)

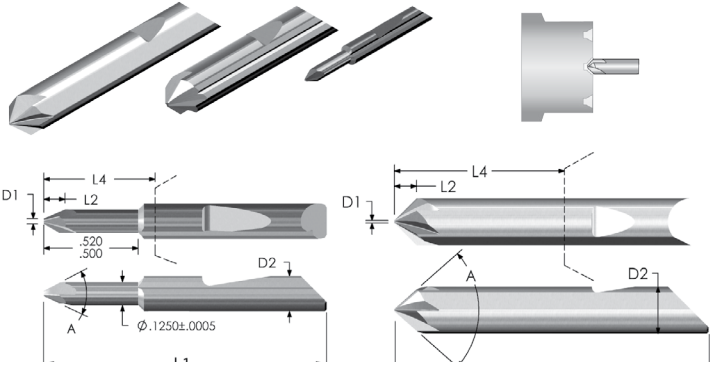

B

Page 274
for Coating
Info

AiTIN – Add "X" to the end of Catalog No.

Other sizes quoted upon request.

QCS Catalog No.	Included Angle (A)	Non-Cutting Diameter (D1)		Length Of Cut (L2)		Number of Flutes	Length From Holder (L4)		Overall Length (L1)
		degrees	inch	mm	inch		mm	inch	
3/16" / 4.8mm Shanks – D2									
QCS-125-060	60°	.030	.76	.082	2.08	3	.590	14.99	1.500
QCS-125-082	82°	.030	.76	.055	1.40	3	.590	14.99	1.500
QCS-125-090	90°	.030	.76	.047	1.19	3	.590	14.99	1.500
QCS-125-100	100°	.030	.76	.040	1.02	3	.590	14.99	1.500
QCS-125-120	120°	.030	.76	.027	.69	3	.590	14.99	1.500
QCS-187-060	60°	.040	1.02	.128	3.25	4	1.090	27.69	2.000
QCS-187-082	82°	.040	1.02	.085	2.16	4	1.090	27.69	2.000
QCS-187-090	90°	.040	1.02	.074	1.88	4	1.090	27.69	2.000
QCS-187-100	100°	.040	1.02	.062	1.57	4	1.090	27.69	2.000
QCS-187-120	120°	.040	1.02	.043	1.09	4	1.090	27.69	2.000
1/4" / 6.4mm Shanks – D2									
QCS-250-060	60°	.050	1.27	.173	4.39	6	1.353	34.37	2.500
QCS-250-082	82°	.050	1.27	.115	2.92	6	1.353	34.37	2.500
QCS-250-090	90°	.050	1.27	.100	2.54	6	1.353	34.37	2.500
QCS-250-100	100°	.050	1.27	.084	2.13	6	1.353	34.37	2.500
QCS-250-120	120°	.050	1.27	.058	1.47	6	1.353	34.37	2.500
5/16" / 7.9mm Shanks – D2									
QCS-312-060	60°	.060	1.52	.219	5.56	6	1.353	34.37	2.500
QCS-312-082	82°	.060	1.52	.145	3.68	6	1.353	34.37	2.500
QCS-312-090	90°	.060	1.52	.126	3.20	6	1.353	34.37	2.500
QCS-312-100	100°	.060	1.52	.106	2.69	6	1.353	34.37	2.500
QCS-312-120	120°	.060	1.52	.073	1.85	6	1.353	34.37	2.500
3/8" / 9.5mm Shanks – D2									
QCS-375-060	60°	.070	1.78	.264	6.71	6	1.353	34.37	2.500
QCS-375-082	82°	.070	1.78	.175	4.45	6	1.353	34.37	2.500
QCS-375-090	90°	.070	1.78	.152	3.86	6	1.353	34.37	2.500
QCS-375-100	100°	.070	1.78	.128	3.25	6	1.353	34.37	2.500
QCS-375-120	120°	.070	1.78	.088	2.24	6	1.353	34.37	2.500
1/2" / 12.7mm Shanks – D2									
QCS-500-060	60°	.080	2.03	.364	9.25	6	1.540	39.12	3.000
QCS-500-082	82°	.080	2.03	.242	6.15	6	1.540	39.12	3.000
QCS-500-090	90°	.080	2.03	.210	5.33	6	1.540	39.12	3.000
QCS-500-100	100°	.080	2.03	.176	4.47	6	1.540	39.12	3.000
QCS-500-120	120°	.080	2.03	.121	3.07	6	1.540	39.12	3.000

Tolerances:

Shank Diameter:

-.0001"(-.0025mm)-.0003"(-.0076mm)

Drill Diameter:

-.0001"(-.0025mm)-.0005"(-.0127mm)

Page 274
for Coating
Info

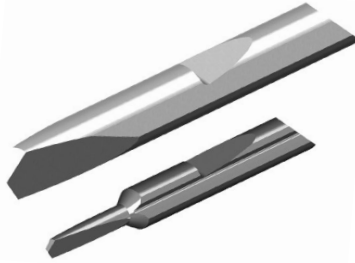

B

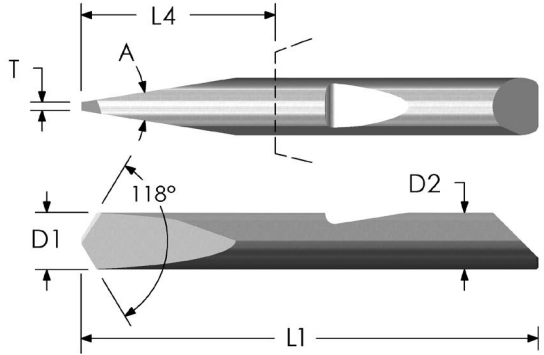
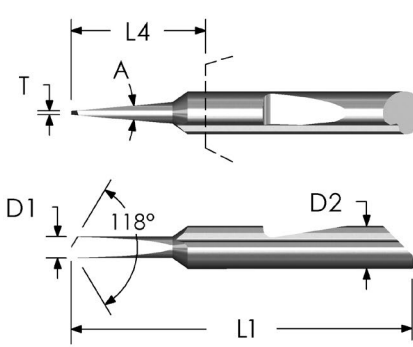

AITiN – Add “X” to the end of Catalog No.

Other sizes quoted upon request.

QSD Catalog No.	Drill Diameter (D1)		Web Thickness (T)		Included Angle of Flutes (A)	Length From Holder (L4)		Overall Length (L1)
	inch	mm	inch	mm		inch	mm	
3/16" / 4.8mm Shanks – D2								
QSD-031	.0312	.79	.010	.25	6°	.340	8.64	1.250
QSD-062	.0625	1.59	.012	.30	10°	.590	14.99	1.500
QSD-093	.0938	2.38	.016	.41	10°	.590	14.99	1.500
QSD-125	.1250	3.18	.020	.51	14°	.590	14.99	1.500
QSD-156	.1562	3.97	.025	.64	16°	1.090	27.69	2.000
QSD-187	.1875	4.76	.028	.71	16°	1.090	27.69	2.000
1/4" / 6.4mm Shanks – D2								
QSD-250	.2500	6.35	.035	.89	18°	.853	21.67	2.000
5/16" / 7.9mm Shanks – D2								
QSD-312	.3125	7.94	.040	1.02	18°	1.353	34.37	2.500
3/8" / 9.5mm Shanks – D2								
QSD-375	.3750	9.53	.046	1.17	18°	1.353	34.37	2.500

For current pricing and availability please visit our website at www.micro100.com

Tolerances:

Shank Diameter:
-.0001"(-.0025mm)-.0003"(-.0076mm)

Pilot Drill Diameter:
+.003"(.08mm)-0"(-0mm)
+.030"(.76mm)-0"(-0mm)

B

Page 274
for Coating
Info

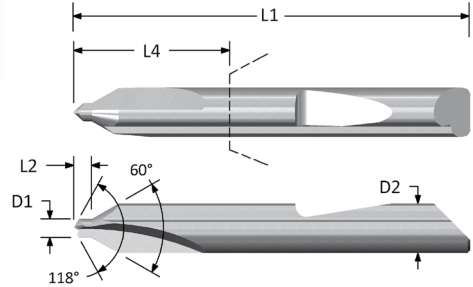
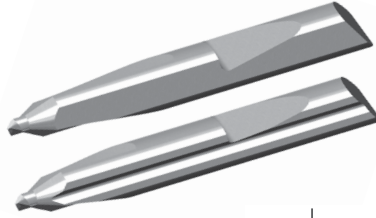

AITiN – Add "X" to the end of Catalog No.

Other sizes quoted upon request.

QDC Catalog No.	Pilot Drill Diameter (D1)		Pilot Drill Length (L2)		Length From Holder (L4)		Overall Length (L1)
	inch	mm	inch	mm	inch	mm	
3/16" / 4.8mm Shanks – D2							
QDC-00	.025	.64	.025	.64	1.090	27.69	2.000
QDC-01	.031	.79	.031	.79	1.090	27.69	2.000
QDC-1	.047	1.19	.047	1.19	1.090	27.69	2.000
QDC-2	.078	1.98	.078	1.98	1.090	27.69	2.000
1/4" / 6.4mm Shanks – D2							
QDC-3	.109	2.77	.109	2.77	1.353	34.37	2.500
5/16" / 7.9mm Shanks – D2							
QDC-4	.125	3.18	.125	3.18	1.353	34.37	2.500
1/2" / 12.7mm Shanks – D2							
QDC-5	.188	4.78	.188	4.78	1.540	39.12	3.000
QDC-6	.219	5.56	.219	5.56	1.540	39.12	3.000

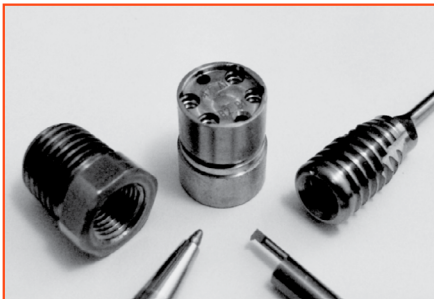

Superior...High Quality...Solid Carbide
Quick-Change Tooling for
Most Machining Applications!

- BORE
- GROOVE
- FACE GROOVE
- PROFILE
- THREAD

FOR MORE DETAILS...
CONTACT YOUR LOCAL AUTHORIZED
MICRO 100 DISTRIBUTOR
OR MICRO 100 SALES REPRESENTATIVE

For current pricing and availability please visit our website at www.micro100.com

FEATURING:

- Unique "3 Point" Locking/Locating System.
- Coolant Port.
- Heat-Treated Tool Holders.

Tolerances:
Shank Diameter: $-.0001"$ ($-.0025\text{mm}$) - $.0003"$ ($-.008\text{mm}$)
Split Face: $0"$ (-0mm)
Centerline: $+.0005"$ ($+.013\text{mm}$) - $0"$ (-0mm)

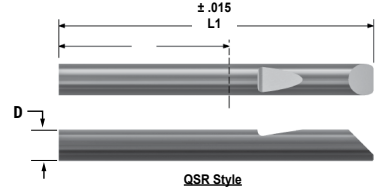
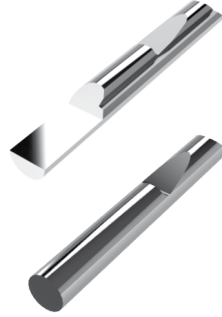
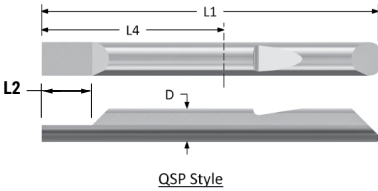

QSP Catalog No.	Split Face Length (L2)		QSR Catalog No.	Usable Blank (L4)		Blank Length (L1)	
	inch	mm		inch	mm	inch	mm
3/16" / 4.8mm Shanks – D							
QSP-187-1.5	.375	9.53	QSR-187-1.5	.590	14.99	1.500	38
QSP-187-2.0	.375	9.53	QSR-187-2.0	1.090	27.69	2.000	51
1/4" / 6.4mm Shanks – D							
QSP-250-2.0	.375	9.53	QSR-250-2.0	.853	21.67	2.000	51
QSP-250-2.5	.375	9.53	QSR-250-2.5	1.353	34.37	2.500	64
QSP-250-3.0	.375	9.53	QSR-250-3.0	1.853	47.07	3.000	76
5/16" / 7.9mm Shanks – D							
QSP-312-2.0	.500	12.70	QSR-312-2.0	.853	21.67	2.000	51
QSP-312-2.5	.500	12.70	QSR-312-2.5	1.353	34.37	2.500	64
QSP-312-3.0	.500	12.70	QSR-312-3.0	1.853	47.07	3.000	76
3/8" / 9.5mm Shanks – D							
QSP-375-2.0	.500	12.70	QSR-375-2.0	.853	21.67	2.000	51
QSP-375-2.5	.500	12.70	QSR-375-2.5	1.353	34.37	2.500	64
QSP-375-3.0	.500	12.70	QSR-375-3.0	1.853	47.07	3.000	76
QSP-375-3.5	.500	12.70	QSR-375-3.5	2.353	59.77	3.500	89
QSP-375-4.0	.500	12.70	QSR-375-4.0	2.853	72.47	4.000	102
1/2" / 12.7mm Shanks – D							
QSP-500-2.5	.625	15.88	QSR-500-2.5	1.040	26.72	2.500	64
QSP-500-3.0	.625	15.88	QSR-500-3.0	1.540	39.12	3.000	76
QSP-500-3.5	.625	15.88	QSR-500-3.5	2.040	51.82	3.500	89
QSP-500-4.0	.625	15.88	QSR-500-4.0	2.540	64.52	4.000	102
QSP-500-4.5	.625	15.88	QSR-500-4.5	3.040	77.22	4.500	114



Grind those "One of a Kind" Specials or Regrind Standard Tools with our QSG Tool Holders featured on page 78

For ordering Blanks with a coolant flat, contact your local Authorized Micro 100 Distributor for more details or call us at 1 (800) 421-8065

For current pricing and availability please visit our website at www.micro100.com

Reduces...

Machine Setup and Downtimes!

QI Catalog No.	Body Length (L2)	
	inch	mm
3/16" / 4.8mm Shank – D2		
QI-187	1.000	25.40
1/4" / 6.4mm Shank – D2		
QI-250	.800	20.32
5/16" / 7.9mm Shank – D2		
QI-312	.800	20.32

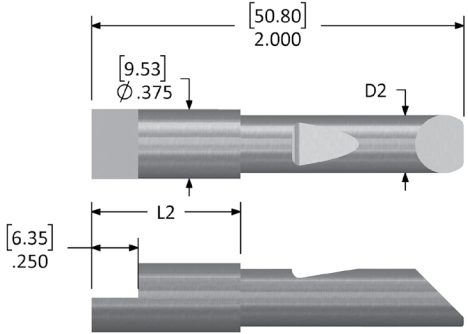

Indicate your Tool Holders...
Quickly and Easily...
Centerline Adjustment in just Seconds!

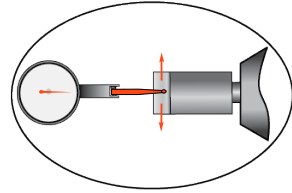
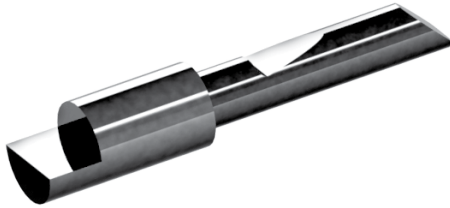

Centerline
Indicating Flat

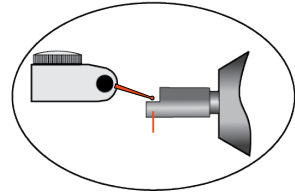

Reduce Machine Setup Times with...
Fast...Accurate...Centerline Indicating Tools.
Designed to fit Micro-Quik Tool Holders.



For current pricing and availability please visit our website at www.micro100.com

FEATURING:

- Modular Quik-Change Tooling System
- Designed for Micro-Quik-, Solid Carbide Tooling
- Coolant Port
- Heat-Treated Tool Holders

Solutions for - Front/Backside Machining

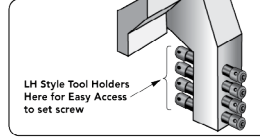

"LH" Style Quick-change Tool Holder Recommended for positioning on "Backside" Tool Block facing Main Spindle for...
Easy Access to LH Set Screws!

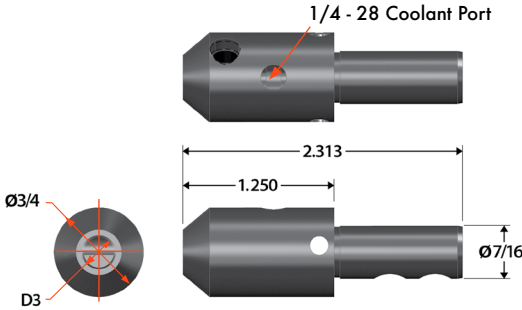
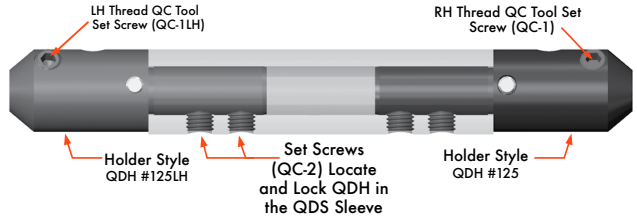

QDH Catalog No.	Bore Diameter (D3)	
	inch	mm
7/16" / 11.1mm Shanks		
QDH-3125	.1875	4.76
QDH-3125LH	.1875	4.76
QDH-4125	.2500	6.35
QDH-4125LH	.2500	6.35
QDH-5125	.3125	7.94
QDH-5125H	.3125	7.94

FEATURING:

- Locating/Locking System for QDH & QDHL holders.
- Heat-Treated Sleeves

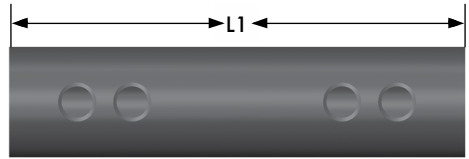
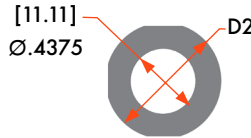

QDS Catalog No.	Overall Length (L1)
	inch
3/4" Sleeve Diameter - D2	
QDS-750-2.5	2.500
QDS-750-3.1	3.100
1" Sleeve Diameter - D2	
QDS-1.00-2.5	2.500
QDS-1.00-3.1	3.100

QDSM Catalog No.	Overall Length (L1)
	mm
20mm Sleeve Diameter - D2	
QDSM-20-64	64
QDSM-20-79	79
22mm Sleeve Diameter - D2	
QDSM-22-64	64
QDSM-22-79	79
25mm Sleeve Diameter - D2	
QDSM-25-64	64

For current pricing and availability please visit our website at www.micro100.com

FEATURING:

- Unique "3 Point" Locking/Locating System ensures Tool to Tool change repeatability.
- Coolant Through Capabilities
- Heat-Treated Tool Holders

Change Tools in
30 seconds or less!

B

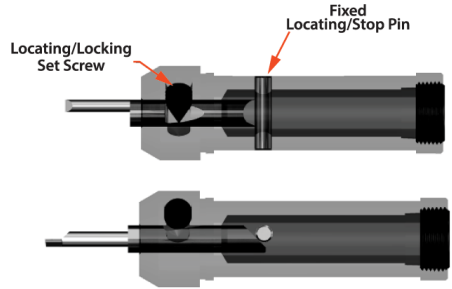
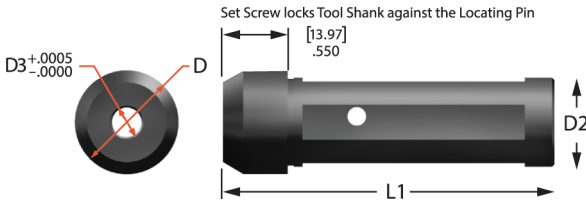

Standard Lengths			
QTH Catalog No.	Internal Diameter (D3)	Collar Diameter (D1)	Overall Length (L1)
	inch	inch	inch
1/2" Shanks – D2			
QTH-85	.1875	.750	2.800
QTH-86	.2500	.750	2.800
5/8" Shanks – D2			
QTH-105	.1875	.750	2.800
QTH-106	.2500	.750	2.800
QTH-107	.3125	.875	2.800
QTH-108	.3750	1.000	2.800
3/4" Shanks – D2			
QTH-205	.1875	.875	2.800
QTH-206	.2500	.875	2.800
QTH-207	.3125	.875	2.800
QTH-208	.3750	1.000	2.800
QTH-210	.5000	1.062	2.800
1" Shanks – D2			
QTH-405	.1875	1.062	2.800
QTH-406	.2500	1.062	2.800
QTH-407	.3125	1.062	2.800
QTH-408	.3750	1.062	2.800
QTH-410	.5000	1.062	2.800
1-1/4" Shanks – D2			
QTH-605	.1875	1.260	2.800
QTH-606	.2500	1.260	2.800
QTH-607	.3125	1.260	2.800
QTH-608	.3750	1.260	2.800
QTH-610	.5000	1.260	2.800

Long Lengths			
QTHL Catalog No.	Internal Diameter (D3)	Collar Diameter (D1)	Overall Length (L1)
	inch	inch	inch
1/2" Shanks – D2			
QTH-85L	.1875	.750	5.800
QTH-86L	.2500	.750	5.800
5/8" Shanks – D2			
QTH-105L	.1875	.750	5.800
QTH-106L	.2500	.750	5.800
QTH-107L	.3125	.875	5.800
QTH-108L	.3750	1.000	5.800
3/4" Shanks – D2			
QTH-205L	.1875	.875	5.800
QTH-206L	.2500	.875	5.800
QTH-207L	.3125	.875	5.800
QTH-208L	.3750	1.000	5.800
QTH-210L	.5000	1.062	5.800
1" Shanks – D2			
QTH-405L	.1875	1.062	5.800
QTH-406L	.2500	1.062	5.800
QTH-407L	.3125	1.062	5.800
QTH-408L	.3750	1.062	5.800
QTH-410L	.5000	1.062	5.800
1-1/4" Shanks – D2			
QTH-605L	.1875	1.260	5.800
QTH-606L	.2500	1.260	5.800
QTH-607L	.3125	1.260	5.800
QTH-608L	.3750	1.260	5.800
QTH-610L	.5000	1.260	5.800

For current pricing and availability please visit our website at www.micro100.com

FEATURING:

- Unique "3 Point" Locking/Locating System ensures Tool to Tool change repeatability.
- Coolant Through Capabilities
- Heat-Treated Tool Holders



Change Tools in
30 seconds or less!

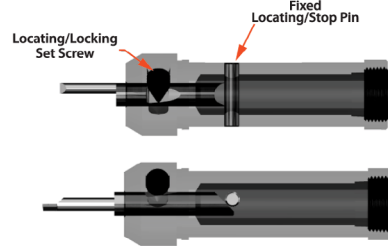
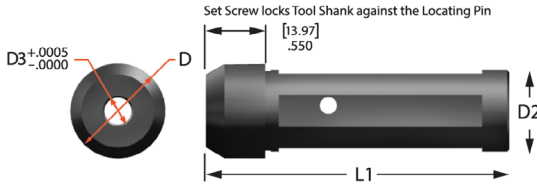

Standard Lengths / Inch			
QTHM Catalog No.	Internal Diameter (D3)	Collar Diameter (D1)	Overall Length (L1)
	inch	inch	inch
12mm Shanks – D2			
QTHM-312	.1875	.750	2.800
QTHM-412	.2500	.750	2.800
16mm Shanks – D2			
QTHM-316	.1875	.750	2.800
QTHM-416	.2500	.750	2.800
QTHM-516	.3125	.875	2.800
QTHM-616	.3750	1.000	2.800
20mm Shanks – D2			
QTHM-320	.1875	.875	2.800
QTHM-420	.2500	.875	2.800
QTHM-520	.3125	.875	2.800
QTHM-620	.3750	1.000	2.800
QTHM-820	.5000	1.062	2.800
22mm Shanks – D2			
QTHM-322	.1875	1.062	2.800
QTHM-422	.2500	1.062	2.800
QTHM-522	.3125	1.062	2.800
QTHM-622	.3750	1.062	2.800
QTHM-822	.5000	1.062	2.800
25 mm Shanks – D2			
QTHM-325	.1875	1.250	2.800
QTHM-425	.2500	1.250	2.800
QTHM-525	.3125	1.250	2.800
QTHM-625	.3750	1.250	2.800
QTHM-825	.5000	1.250	2.800
32mm Shanks – D2			
QTHM-332	.1875	1.260	2.800
QTHM-432	.2500	1.260	2.800
QTHM-532	.3125	1.260	2.800
QTHM-632	.3750	1.260	2.800
QTHM-832	.5000	1.260	2.800

Long Lengths / Inch			
QTHM Catalog No.	Internal Diameter (D3)	Collar Diameter (D1)	Overall Length (L1)
	inch	inch	inch
12mm Shanks – D2			
QTHM-312L	.1875	.750	5.800
QTHM-412L	.2500	.750	5.800
16mm Shanks – D2			
QTHM-316L	.1875	.750	5.800
QTHM-416L	.2500	.750	5.800
QTHM-516L	.3125	.875	5.800
QTHM-616L	.3750	1.000	5.800
20mm Shanks – D2			
QTHM-320L	.1875	1.062	5.800
QTHM-420L	.2500	1.062	5.800
QTHM-520L	.3125	1.062	5.800
QTHM-620L	.3750	1.062	5.800
QTHM-820L	.5000	1.062	5.800
22mm Shanks – D2			
QTHM-322L	.1875	1.062	5.800
QTHM-422L	.2500	1.062	5.800
QTHM-522L	.3125	1.062	5.800
QTHM-622L	.3750	1.062	5.800
QTHM-822L	.5000	1.062	5.800
25 mm 1-1/4" Shanks – D2			
QTHM-325L	.1875	1.250	5.800
QTHM-425L	.2500	1.250	5.800
QTHM-525L	.3125	1.250	5.800
QTHM-625L	.3750	1.250	5.800
QTHM-825L	.5000	1.250	5.800
32mm Shanks – D2			
QTHM-332L	.1875	1.260	5.800
QTHM-432L	.2500	1.260	5.800
QTHM-532L	.3125	1.260	5.800
QTHM-632L	.3750	1.260	5.800
QTHM-832L	.5000	1.260	5.800

FEATURING:

- Precision Ground Heat Treated Steel Shanks
- Coolant thru shanks machined with National Pipe Threads

B

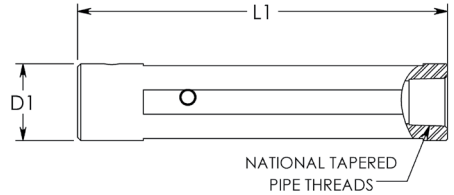
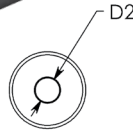
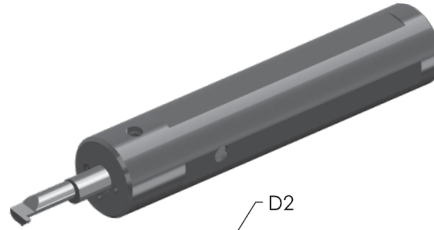

QTC HOLDER Catalog No.	Internal Diameter (D2)	Holder Diameter (D1)	Holder Length (L1)	NPT Size and T.P.I.	QTC HOLDER Catalog No.	Internal Diameter (D2)	Holder Diameter (D1)	Holder Length (L1)	NPT Size and T.P.I.
	inch	inch	inch			inch	inch	inch	
REGULAR LENGTH					LONG LENGTH				
QTC-85	0.1875	1/2	2.8	1/8-27	QTC-85L	0.1875	1/2	5.8	1/8-27
QTC-86	0.2500	1/2	2.8	1/8-27	QTC-86L	0.2500	1/2	5.8	1/8-27
QTC-105	0.1875	5/8	2.8	1/4-18	QTC-105L	0.1875	5/8	5.8	1/4-18
QTC-106	0.2500	5/8	2.8	1/4-18	QTC-106L	0.2500	5/8	5.8	1/4-18
QTC-107	0.3125	5/8	2.8	1/4-18	QTC-107L	0.3125	5/8	5.8	1/4-18
QTC-108	0.3750	5/8	2.8	1/4-18	QTC-108L	0.3750	5/8	5.8	1/4-18
QTC-205	0.1875	3/4	2.8	3/8-18	QTC-205L	0.1875	3/4	5.8	3/8-18
QTC-206	0.2500	3/4	2.8	3/8-18	QTC-206L	0.2500	3/4	5.8	3/8-18
QTC-207	0.3125	3/4	2.8	3/8-18	QTC-207L	0.3125	3/4	5.8	3/8-18
QTC-208	0.3750	3/4	2.8	3/8-18	QTC-208L	0.3750	3/4	5.8	3/8-18
QTC-210	0.5000	3/4	2.8	1/2-14	QTC-210L	0.5000	3/4	5.8	1/2-14
QTC-405	0.1875	1.0	2.8	3/8-18	QTC-405L	0.1875	1.0	5.8	3/8-18
QTC-406	0.2500	1.0	2.8	3/8-18	QTC-406L	0.2500	1.0	5.8	3/8-18
QTC-407	0.3125	1.0	2.8	3/8-18	QTC-407L	0.3125	1.0	5.8	3/8-18
QTC-408	0.3750	1.0	2.8	3/8-18	QTC-408L	0.3750	1.0	5.8	3/8-18
QTC-410	0.5000	1.0	2.8	1/2-14	QTC-410L	0.5000	1.0	5.8	1/2-14
QTC-605	0.1875	1-1/4	2.8	3/8-18	QTC-605L	0.1875	1-1/4	5.8	3/8-18
QTC-606	0.2500	1-1/4	2.8	3/8-18	QTC-606L	0.2500	1-1/4	5.8	3/8-18
QTC-607	0.3125	1-1/4	2.8	3/8-18	QTC-607L	0.3125	1-1/4	5.8	3/8-18
QTC-608	0.3750	1-1/4	2.8	3/8-18	QTC-608L	0.3750	1-1/4	5.8	3/8-18
QTC-610	0.5000	1-1/4	2.8	1/2-14	QTC-610L	0.5000	1-1/4	5.8	1/2-14

For current pricing and availability please visit our website at www.micro100.com

FEATURING:

- Precision Ground Heat Treated Steel Shanks
- Coolant thru shanks machined with National Pipe Threads

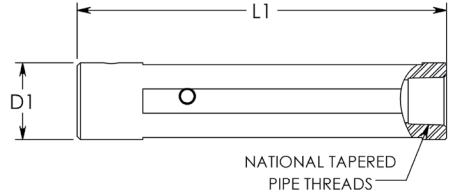
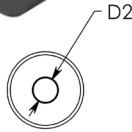
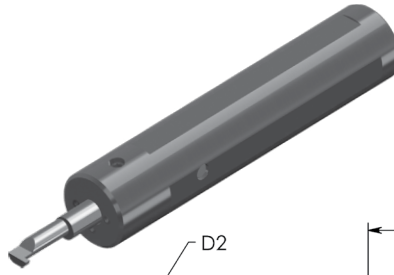

QTCM HOLDER Catalog No.	Internal Diameter (D2)	Holder Diameter (D1)	Holder Length (L1)	NPT Size and T.P.I.
	inch	mm	mm	
REGULAR LENGTH				
QTCM-312	0.1875	12	71	1/4-18
QTCM-412	0.2500	12	71	1/4-18
QTCM-316	0.1875	16	71	1/4-18
QTCM-416	0.2500	16	71	1/4-18
QTCM-516	0.3125	16	71	1/4-18
QTCM-616	0.3750	16	71	1/4-18
QTCM-320	0.1875	20	71	1/4-18
QTCM-420	0.2500	20	71	1/4-18
QTCM-520	0.3125	20	71	3/8-18
QTCM-620	0.3750	20	71	3/8-18
QTCM-820	0.5000	20	71	1/2-14
QTCM-322	0.1875	22	71	3/8-18
QTCM-422	0.2500	22	71	3/8-18
QTCM-522	0.3125	22	71	3/8-18
QTCM-622	0.3750	22	71	3/8-18
QTCM-822	0.5000	22	71	1/2-14
QTCM-325	0.1875	25	71	3/8-18
QTCM-425	0.2500	25	71	3/8-18
QTCM-525	0.3125	25	71	3/8-18
QTCM-625	0.3750	25	71	3/8-18
QTCM-825	0.5000	25	71	1/2-14
QTCM-332	0.1875	32	71	3/8-18
QTCM-432	0.2500	32	71	3/8-18
QTCM-532	0.3125	32	71	3/8-18
QTCM-632	0.3750	32	71	3/8-18
QTCM-832	0.5000	32	71	1/2-14

QTCM HOLDER Catalog No.	Internal Diameter (D2)	Holder Diameter (D1)	Holder Length (L1)	NPT Size and T.P.I.
	inch	mm	mm	
LONG LENGTH				
QTCM-312L	0.1875	12	147	1/4-18
QTCM-412L	0.2500	12	147	1/4-18
QTCM-316L	0.1875	16	147	1/4-18
QTCM-416L	0.2500	16	147	1/4-18
QTCM-516L	0.3125	16	147	1/4-18
QTCM-616L	0.3750	16	147	1/4-18
QTCM-320L	0.1875	20	147	1/4-18
QTCM-420L	0.2500	20	147	1/4-18
QTCM-520L	0.3125	20	147	3/8-18
QTCM-620L	0.3750	20	147	3/8-18
QTCM-820L	0.5000	20	147	1/2-14
QTCM-322L	0.1875	22	147	3/8-18
QTCM-422L	0.2500	22	147	3/8-18
QTCM-522L	0.3125	22	147	3/8-18
QTCM-622L	0.3750	22	147	3/8-18
QTCM-822L	0.5000	22	147	1/2-14
QTCM-325L	0.1875	25	147	3/8-18
QTCM-425L	0.2500	25	147	3/8-18
QTCM-525L	0.3125	25	147	3/8-18
QTCM-625L	0.3750	25	147	3/8-18
QTCM-825L	0.5000	25	147	1/2-14
QTCM-332L	0.1875	32	147	3/8-18
QTCM-432L	0.2500	32	147	3/8-18
QTCM-532L	0.3125	32	147	3/8-18
QTCM-632L	0.3750	32	147	3/8-18
QTCM-832L	0.5000	32	147	1/2-14

For current pricing and availability please visit our website at www.micro100.com

Featuring the UNIQUE QUIK-CHANGE Tooling System

B



Micro-Quik Tool Projection and Tool Length Repeatability.

The **Micro-Quik** tooling system ensures a high degree of tool length repeatability. At tool change, the precisely ground bevel on the rear of the tool registers on a tooling pin. The distance from this registration point to the tip of the tool "A" is controlled to ± 0.001 " (0.25mm). Dimension "A" can only be measured using optical means, such as an optical comparator.

The overall length of the tool (L1) is not controlled to the same high degree of accuracy, since the rearmost feature of the tool does not affect the position of the cutting face.

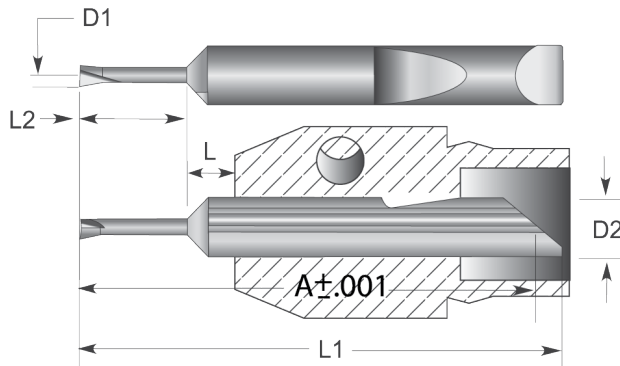

FEATURING:

- Unique "3 Point" Locking/Locating System
- Specifically designed and engineered for STAR CNC Swiss type machines
- Coolant Port
- Heat-Treated Tool Holders

Reduce Setup time!

Change Tools in
30 seconds or less!

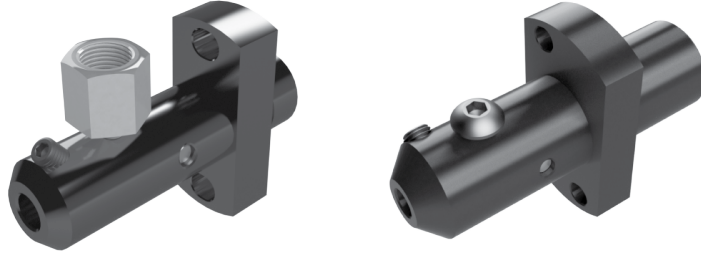

Extended Lengths for SR10J Types Machines

QZST SR10J TYPE Catalog No.	Internal Diameter (D3)		Holder Length (L2)		Overall Length (L1)	
	inch	mm	inch	mm	inch	mm
22mm Shanks – D2						
QZST-316L-SR10J	.1875	4.76	1.606	41	2.350	60
QZST-416L-SR10J	.2500	6.35	1.606	41	2.350	60
QZST-516L-SR10J	.3125	7.94	1.606	41	2.350	60

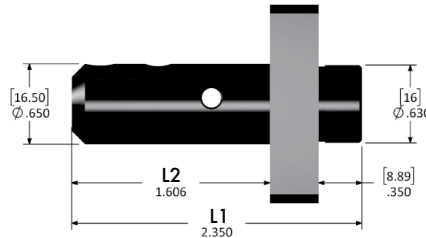
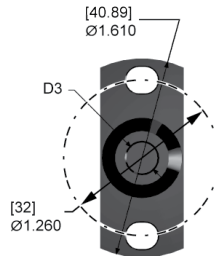

For current pricing and availability please visit our website at www.micro100.com

FEATURING:

- Unique "3 Point" Locking/Locating System
- Specifically designed and engineered for STAR CNC Swiss type machines
- Coolant Port
- Heat-Treated Tool Holders

Reduce Setup time!

Change Tools in
30 seconds or less!

B

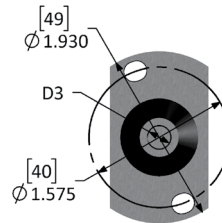
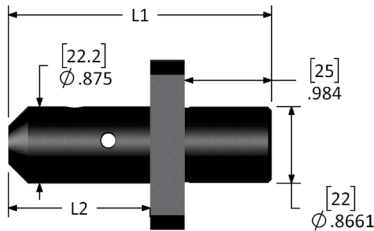

Standard and Extended Lengths for SR20 Types Machines

QZST SR20 TYPE Catalog No.	Internal Diameter (D3)		Holder Length (L2)		Overall Length (L1)	
	inch	mm	inch	mm	inch	mm
22mm Shanks – D2						
QZST-322-SR20	.1875	4.76	1.006	25	2.384	61
QZST-322L-SR20	.1875	4.76	1.606	41	2.984	76
QZST-422-SR20	.2500	6.35	1.006	25	2.384	61
QZST-422L-SR20	.2500	6.35	1.606	41	2.984	76
QZST-522-SR20	.3125	7.94	1.006	25	2.384	61
QZST-522L-SR20	.3125	7.94	1.606	41	2.984	76

For current pricing and availability please visit our website at www.micro100.com

FEATURING:

- Unique "3 Point" Locking/Locating System
- Specifically designed and engineered for STAR CNC Swiss type machines
- Coolant Port
- Heat-Treated Tool Holders

Reduce Setup time!

**Change Tools in
30 seconds or less!**

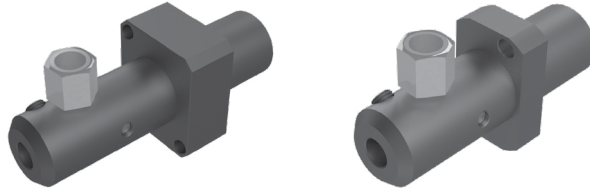

B

**Extended Lengths for SR20RIV
Types Machines**

QZST SR20 TYPES* Catalog No.	Internal Diameter (D3)		Holder Length (L2)		Overall Length (L1)	
	inch	mm	inch	mm	inch	mm
22mm Shanks – D2						
QZST-322L-SR20RIV	.1875	4.76	1.85	47	3.494	89
QZST-422L-SR20RIV	.2500	6.35	1.85	47	3.494	89
QZST-522L-SR20RIV	.3125	7.94	1.85	47	3.494	89

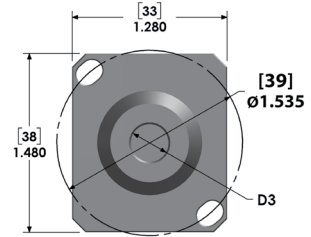
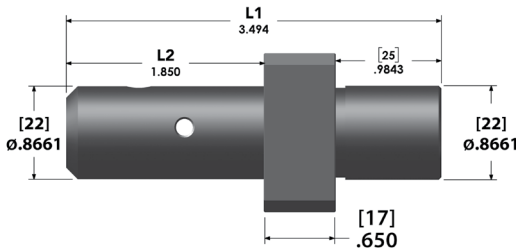

Standard Lengths for SW20 Types Machines

QZST SW20 TYPES Catalog No.	Internal Diameter (D3)		Holder Length (L2)		Overall Length (L1)	
	inch	mm	inch	mm	inch	mm
22mm Shanks – D2						
QZST-322L-SW20	.1875	4.76	1.606	41	2.984	76
QZST-422L-SW20	.2500	6.35	1.606	41	2.984	76
QZST-522L-SW20	.3125	7.94	1.606	41	2.984	76

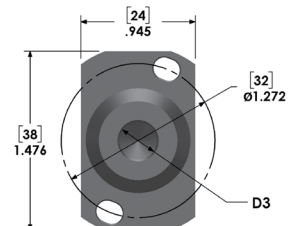
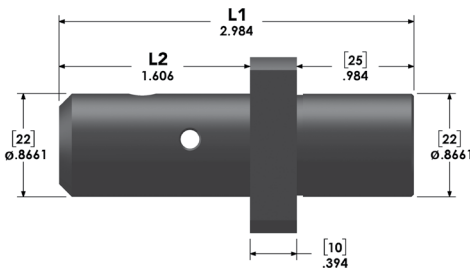

FEATURING:

- Unique "3 Point" Locking/ Locating System.
- Ideal Quick-Change System for Gang Tool Machines and standard lathes.
- Heat Treated Tool Holders.

B

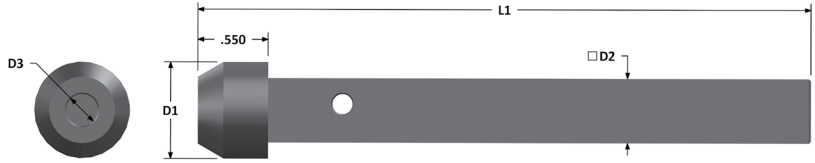
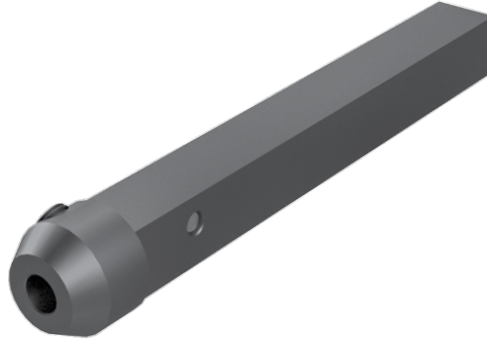

Great for...
**Gang Tool Machines
and Standard Lathes!**

QSG Catalog No.	Internal Diameter (D3)		Collar Diameter (D1)		Overall Length (L1)	
	inch	mm	inch	mm	inch	mm
1/2" 12.7mm Square Shanks – D2						
QSG-187-500	.1875	4.76	.750	19.05	4.800	122
QSG-250-500	.2500	6.35	.750	19.05	4.800	122
QSG-312-500	.3125	7.94	.875	22.23	4.800	122
3/4" 19.1mm Square Shanks – D2						
QSG-187-750	.1875	4.76	1.063	27.00	4.800	122
QSG-250-750	.2500	6.35	1.063	27.00	4.800	122
QSG-312-750	.3125	7.94	1.063	27.00	4.800	122
QSG-375-750	.3750	9.53	1.063	27.00	4.800	122
QSG-500-750	.5000	12.70	1.063	27.00	4.800	122

Quik-CHANGE Tooling System from the name you can TRUST!

HIGH QUALITY... ULTRA PRECISION!

QUIK-CHANGE

BORING, GROOVING, PROFILING, AND THREADING TOOLING SYSTEM

For current pricing and availability please visit our website at www.micro100.com

FEATURING:

- Unique "3 Point" Locking/Locating System ensures Tool to Tool change repeatability.
- Coolant Through Shanks.
- Heat Treated Tool Holders.

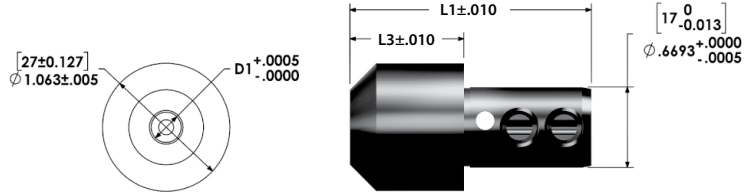

**Ultra Precision...
Quik-Change Boring System**

QTHM Catalog No.	Internal Diameter (D1)		Collar Length (L3)		Overall Length (L1)	
	inch	mm	inch	mm	inch	mm
17mm Shanks						
QTHM-317	.1875	4.76	.750	19.05	1.813	46
QTHM-417	.2500	6.35	.950	24.13	2.013	51
QTHM-517	.3125	7.94	.950	24.13	2.013	51
QTHM-617	.3750	9.52	.950	24.13	1.963	50
QTHM-817	.5000	12.70	1.475	34.47	2.538	64

QMBB



Miniature Boring Tools
Min. Bore Ranges:
.015" - .100"
Coated/Uncoated Grades



QBB



Boring Tools
Min. Bore Ranges:
.050" - .490"
Coated/Uncoated Grades



Ultra Precision Boring Tools Specifically Engineered and Designed for Boring Head Applications

QBM



Boring Tools
Min. Bore Ranges:
.118" - .460"
Coated/Uncoated Grades



QFG



Face Grooving Tools
Min. Groove Width Ranges:
.020" - .156"
Coated/Uncoated Grades



For current pricing and availability please visit our website at www.micro100.com

B



ACCESSORY Catalog No.	ACCESSORY DESCRIPTION	
QC-1	Locating/Locking Screw (Right Hand Threads) Fits: QTH, QTHM, QZST, QSG, QDH – Requires QHT-1 Hex Key	
QC-10	Package of ten QC-1 Locating/Locking Screws (Right Hand Threads) Fits: QTH, QTHM, QZST, QSG, QDH – Requires QHT-1 Hex Key	
QC-1LH	Locating/Locking Screw (Left Hand Threads) Fits: QDH – Requires QHT-1 Hex Key	
QC-10LH	Package of ten QC-1LH Locating/Locking Screw (Left Hand Threads) Fits: QDH / Requires QHT-1 Hex Key	
QC-2	Locating/Locking Screw Fits: QDS, QDSM / Requires QHT - 1 Hex Key	
QC-20	Package of ten QC-2 Locating/Locking Screws Fits: QDS, QDSM / Requires QHT - "T" Style Handle Hex Wrench	
QC-5	Button Head Screw (Plug) for High Pressure Coolant Fits: QDH, QZST / Hex Key not stocked for this item	
QC-50	Package of ten QC-5 Button Head Screws (Plugs) for High Pressure Coolant Fits: QDH, QZST / Hex Key not stocked for this item	
QC-6	Socket Set Screw Fits: QZST-SR10J / Requires 3/32" Hex Key	
QC-60	Package fo ten QC-6 Socket Set Screws Fits: QZST-SR10J / Requires 3/32" Hex Key	
QN-1	High Pressure Coolant Fitting Fits: QZST, QDH	
QN-10	Package of ten QN-1 High Pressure Coolant Fittings Fits: QC-3, QC-4 Locking Screws	
QHK-1	Hex Wrench Fits: QC-3, QC-4 Locking Screws	
QHK-10	Package of ten QHK-1 Hex Wrenches Fits: QC-3, QC-4 Locking Screws	
QHK-2	Hex Wrench Fits: QC-6 Socket Set Screws	
QHK-20	Package of ten QHK-2 Hex Wrenches Fits: QC-6 Socket Set Screws	
QHT-1	"T" Style Handle Hex Wrench Fits: QC-1, QC-1LH, QC-2 Locating/Locking Screws	
QHT-10	Package of ten QHT-1 "T" Style Handle Hex Wrench Fits: QC-1, QC-1LH, QC-2 Locating/Locking Screws	

For current pricing and availability please visit our website at www.micro100.com

*World Class Quality
Through Manufacturing Excellence*

MICRO 100®
super carbide tools

*Combined with Superior Strength and Wear
Characteristics Provides Unmatched High
Performance Productivity at it's BEST!*



C

- Thread Mills
- Back Chamfering and Thread Relief Tools
- Keyseat Cutters
- Dovetail Cutters
- Mold Making Runner Cutters
- Die Sink Cutters
- Single Flute and Diamond Cut Routers
- Countersink and Chamfering Tools
- Combination Drill and Countersink Tools
- Spade Drills, Spotting and Centering Drills, Jobber Length Drills
- Engraving Tools
- Full Radius Tools
- Tangential Blades
- Slitting Blade
- Speedy Sharp



**WILL NOT CHIP OR BREAK
UNDER NORMAL MACHINING CONDITIONS**



Helical Thread Mills

Style TM
pages 84 - 85



Die Sink Cutters

Style DSC
page 94



Thread Mills

Style TM
pages 86 - 87

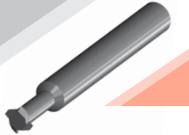

Single Flute Routers

Style SFA, SFP, SFL
page 95



Brazed Back Chamfering Tools

Style MBC for Milling Machines
page 88

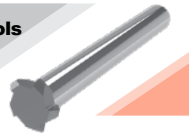

Single Flute Routers

Style SFP & SFL
Right/Left Hand Spiral, Right Hand
page 95

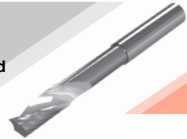

Brazed Thread Relief Tools

STYLE MTR for Milling Machines
page 88

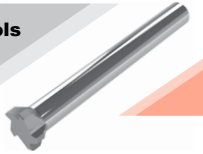

Diamond Cut Routers

Styles RDA, RDB, RDC, RDD & RDE
page 96



Keyseat Cutters

Style KC
pages 89 - 91

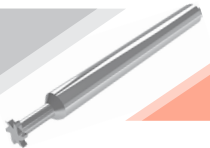

Countersink & Chamfering Tools

Style CS
page 97



Dovetail Cutters

Style DT
page 92



Combined Drills & Countersinks

Style DC
page 98



Moldmaking Runner Cutters

Style MRT, MRF
page 93



Spade Drills

Style SD
page 99

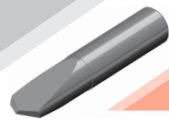

For current pricing and availability please visit our website at www.micro100.com

C

Spotting & Centering Drills

Style SPD
page 100



Full Radius Tools

Style RSF
page 107



Jobber Length Drills

Style DR
pages 101



Tangential Blades

Style TANG
page 108

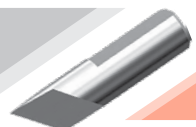

Engraving Tools

Style RTC, RSC & RNC
pages 102 - 105

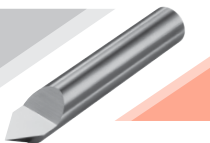

Slitting Blade

Style PZ-1
page 108



Split-End Blanks

Style RS
page 106

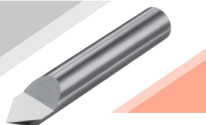

Speedy Sharp

Style KS1
page 109



The most universal sharpener ever manufactured!

It sharpens fast, is durable, and compact! Speedy Sharp is the most effective sharpener you will ever use.
It will literally sharpen anything with an edge from knives to lawn mower blades!

SHARPEN: Knives • Scissors • Chisels • Carpet Knives • Razor Blades • Broadhead Arrows
Fish Hooks • Serrated Knives • Axes • Router Bits • Planer Blades • Gardening Tools... and much more!

www.speedysharp.com

FEATURING:

- Helical flute design for reducing cutting forces, smooth cuts, longest tool life, and maximum thread milling performances.
- 100% thread form, superior threads vs. tapping.
- Cuts right hand and left hand quality threads.
- Suitable for all types of materials, especially heat treated and difficult to machine workpiece metals.
- Uncoated thread mills are also available from stock.



Tolerances:
Shank Diameter: $-.0001''$ -. $0003''$
Length of Cut: $+0.030''$ -. $0''$
Overall Length: $\pm 0.015''$

For programming and technical assistance, go to www.micro100.com to download our "Thread Mill Auto Assist" program.

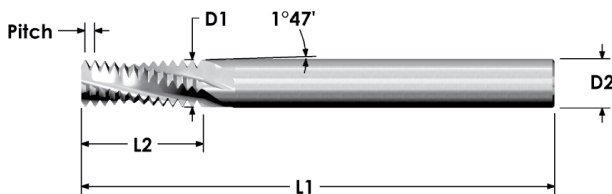

End Mills Coated with:

AlTiN

Metric sizes also available.

TM Catalog No.		Cutter Diameter (D1)	Normal Size and TPI	Number of Flutes	Length of Cut (L2)	Overall Length (L1)
Uncoated	Coated	inch			inch	inch
1/4" Shanks – D2						
TM-112-40	TM-112-40X	.080	4-40	2	.1875	2.000
TM-138-32	TM-138-32X	.100	6-32	2	.2500	2.000
TM-164-32	TM-164-32X	.115	8-32	3	.2500	2.000
TM-190-24	TM-190-24X	.120	10-24	3	.3125	2.000
TM-190-28 ♦	TM-190-28X ♦	.120	10-28	3	.3125	2.000
TM-190-32	TM-190-32X	.120	10-32	3	.3125	2.000
TM-250-20	TM-250-20X	.180	1/4-20	3	.5000	2.500
TM-250-28	TM-250-28X	.180	1/4-28	3	.5000	2.500
TM-312-18	TM-312-18X	.235	5/16-18	3	.6250	2.500
TM-312-24	TM-312-24X	.235	5/16-24	3	.6250	2.500
5/16" Shanks – D2						
TM-375-16	TM-375-16X	.285	3/8-16	4	.750	2.500
TM-375-24	TM-375-24X	.285	3/8-24	4	.750	2.500
TM-437-14	TM-437-14X	.305	7/16-14	4	.750	2.500
3/8" Shanks – D2						
TM-437-20	TM-437-20X	.335	7/16-20	4	.8750	3.000
TM-500-13	TM-500-13X	.350	1/2-13	4	.8750	3.000
TM-562-12	TM-562-12X	.370	9/16-12	4	.8750	3.000
TM-562-18	TM-562-18X	.370	9/16-18	4	.8750	3.000
1/2" Shanks – D2						
TM-625-11	TM-625-11X	.470	5/8-11	4	1.2500	4.000
TM-750-10	TM-750-10X	.495	3/4-10	4	1.2500	4.000
TM-750-12	TM-750-12X	.495	3/4-12	4	1.2500	4.000
TM-750-16	TM-750-16X	.495	3/4-16	4	1.2500	4.000
TM-875-14	TM-875-14X	.490	7/8-14	4	1.2500	4.000
5/8" Shanks – D2						
TM-875-09	TM-875-09X	.620	7/8-9	4	1.3750	4.000
TM-001-08	TM-001-08X	.620	1-8	4	1.3750	4.000

♦ WHILE SUPPLIES LAST - Discontinued

FEATURING:

- Helical flute design for reducing cutting forces, smooth cuts, longest tool life, and maximum thread milling performances.
- 100% thread form, superior threads vs. tapping.
- Cuts right hand and left hand quality threads.
- Suitable for all types of materials, especially heat treated and difficult to machine workpiece metals.
- Uncoated thread mills are also available from stock.



Tolerances:
Shank Diameter: $-.0001''$ - $-.0003''$
Length of Cut: $+.030''$ / $-0''$
Overall Length: $\pm .015''$

Page 274
for Coating
Info

C

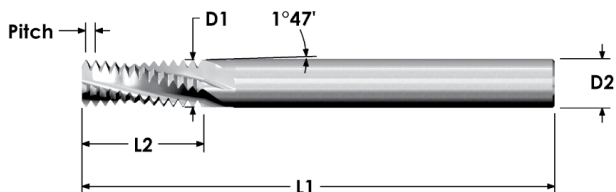

End Mills Coated with:

AlTiN

Metric sizes also available.

TM Catalog No.		NPT Size	TPI	Large End Cutter Diameter (D1) inch	Number of Flutes	Length of Cut (L2) inch	Overall Length (L1) inch
Uncoated	Coated						
1/4" Shanks – D2							
TM-27NPT	TM-27NPTX	1/16 & 1/8 NPT	27	.245	3	.437	2.500
5/16" Shanks – D2							
TM-18NPT	TM-18NPTX	1/4 & 3/8 NPT	18	.305	4	.625	3.000
1/2" Shanks – D2							
TM-14NPT	TM-14NPTX	1/2 & 3/4 NPT	14	.495	4	.875	4.000
5/8" Shanks – D2							
TM-11NPT	TM-11NPTX	1" & 2" NPT	11.5	.620	4	1.125	4.000

TM Catalog No.		Thread Size	Pitch	Large End Cutter Diameter (D1) inch	Number of Flutes	Length of Cut (L2) inch	Overall Length (L1) inch
Uncoated	Coated						
1/4" Shanks – D2							
TM-27NPTF	TM-27NPTFX	1/16 & 1/8 NPTF	27	.245	3	.437	2.500
5/16" Shanks – D2							
TM-18NPTF	TM-18NPTFX	1/4 & 3/8 NPTF	18	.305	4	.625	3.000
1/2" Shanks – D2							
TM-14NPTF	TM-14NPTFX	1/2 & 3/4 NPTF	14	.495	4	.875	4.000
5/8" Shanks – D2							
TM-11NPTF	TM-11NPTFX	1" & 2" NPTF	11.5	.620	4	1.125	4.000

For programming and technical assistance, go to www.micro100.com to download our "Thread Mill Auto Assist" program.

FEATURING:

- Engineered for milling precision I.D. and O.D. threads in all types of **steels, non-ferrous metals and exotic materials.**
- Equally effective in laminated plastics, fibreglasses and composites used in the aircraft industry.
- U.N. Thread Form.
- Solid Carbide Cutter.



Tolerances:
Cutter Diameter: +0/--.005"
Shank Diameter: -.0001"/-.0003"
Overall Length: ±.015"

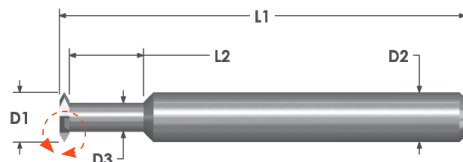
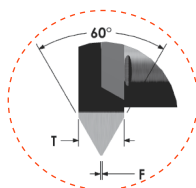

AiTIn – Add “X” to the end of Catalog No.

TM Catalog No.	Cutter Diameter (D1)	Number of Flutes	Neck Diameter (D3)	Neck Length (L2)	Flat (F)	Thickness (T)	Pitch	Overall Length (L1)
	inch		inch	inch	inch	inch		inch
1/8" Shanks – D2								
TM-060-4	.060	2	.030	1/4	SHARP	.017	56 TO 80	1.500
TM-060-6	.060	2	.030	3/8	SHARP	.017	56 TO 80	1.500
TM-080-4	.080	2	.035	1/4	SHARP	.026	40 TO 64	1.500
TM-080-8	.080	2	.035	1/2	SHARP	.026	40 TO 64	1.500
TM-100-6	.100	2	.050	3/8	SHARP	.029	32 TO 64	1.500
TM-100-8	.100	2	.050	1/2	SHARP	.029	32 TO 64	1.500
TM-100-10	.100	2	.050	5/8	SHARP	.029	32 TO 64	2.000
3/16" Shanks – D2								
TM-120-6	.120	3	.070	3/8	.001	.030	32 TO 56	2.000
TM-120-8	.120	3	.070	1/2	.001	.030	32 TO 56	2.000
TM-120-10	.120	3	.070	5/8	.001	.030	32 TO 56	2.000
TM-140-8	.140	3	.075	1/2	.001	.038	24 TO 56	2.000
TM-140-12	.140	3	.075	3/4	.001	.038	24 TO 56	2.000
1/4" Shanks – D2								
TM-180-8	.180	4	.090	1/2	.002	.055	18 TO 56	2.500
TM-180-12	.180	4	.090	3/4	.002	.055	18 TO 56	2.500
TM-180-16	.180	4	.090	1	.002	.055	18 TO 56	2.500
TM-250-16	.250	4	.100	1	.002	.065	14 TO 48	2.500
TM-250-18	.250	4	.150	1-1/8	.002	.060	16 TO 48	2.500
5/16" Shanks – D2								
TM-250-24	.250	4	.150	1-1/2	.002	.055	16 TO 48	3.500
3/8" Shanks – D2								
TM-290-16	.290	4	.170	1	.002	.071	14 TO 40	4.000
TM-360-16	.360	4	.210	1	.002	.085	12 TO 32	4.000
1/2" Shanks – D2								
TM-490-16	.490	5	.300	1	.0035	.095	11 TO 32	4.000
TM-490-20	.490	5	.300	1-1/4	.0035	.095	11 TO 32	4.000
5/8" Shanks – D2								
TM-600-16	.600	6	.420	1	.004	.100	10 TO 32	4.000
TM-600-20	.600	6	.420	1-1/4	.004	.100	10 TO 32	4.000
3/4" Shanks – D2								
TM-720-20	.720	6	.360	1-1/4	.0045	.200	5 TO 12	4.000
TM-720-32	.720	6	.360	2	.0045	.200	5 TO 12	4.000
TM-720-40	.720	6	.360	2-1/2	.0045	.200	5 TO 12	4.000

FEATURING:

- Engineered for milling precision I.D. and O.D. threads in all types of steels, non-ferrous metals and exotic materials.
- Equally effective in laminated plastics, fibreglasses and composites used in the aircraft industry.
- U.N. Thread Form.
- Solid carbide cutter brazed to solid carbide shank for maximum rigidity.



Tolerances:
Cutter Diameter: +0/-0.005"
Shank Diameter: -0.001"/-0.0003"

**Page 274
for Coating
Info**

C

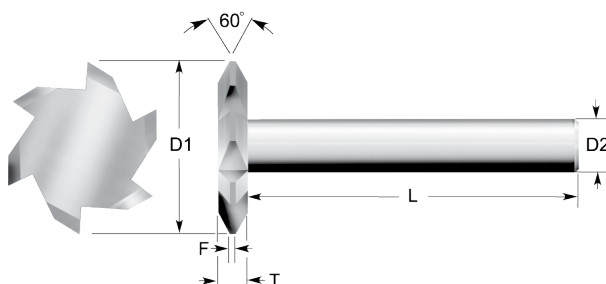

AITiN – Add "X" to the end of Catalog No.

TM Catalog No.	Cutter Diameter (D1)	Number of Flutes	Flat (F)	Thickness (T)	Pitch	Shank Length (L)
	inch		inch	inch		inch
1/4" Shanks – D2						
TM-375	.375	4	.002	.093	12 to 32	2.500
5/16" Shanks – D2						
TM-500	.500	5	.002	.125	11 to 32	2.500
3/8" Shanks – D2						
TM-750	.750	6	.004	.156	7 to 16	2.500
1/2" Shanks – D2						
TM-001	1.000	7	.0045	.187	5 to 12	3.000

**For programming and technical assistance, go to
www.micro100.com to download our "Thread
Mill Auto Assist" program.**

Tolerances:
 Shank Diameter: $-.0001"/-.0003"$
 Cutter Diameter: $+0"/-.005"$
 Flat: $+0"/-.005"$

Page 274
for Coating
Info

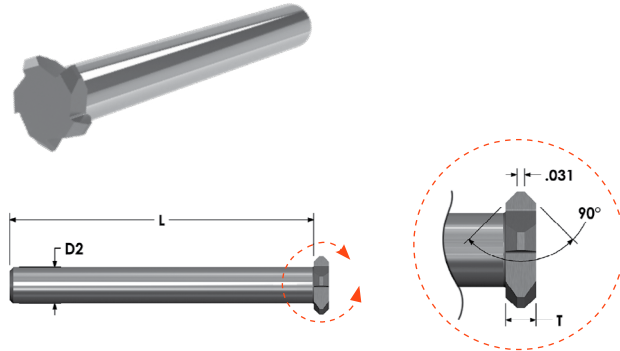

MBC Catalog No.	Cutter Diameter (D1)	Thickness (T)	Number of Flutes	Shank Length (L)
	inch	inch		inch
1/4" Shank – D2				
MBC-375	.375	1/8	4	2.500
5/16" Shank – D2				
MBC-500	.500	1/8	5	2.500
3/8" Shank – D2				
MBC-750	.750	5/32	6	2.500
1/2" Shank – D2				
MBC-001	1.000	3/16	7	3.000

MTR Tolerances:
 Shank Diameter: $-.0001"/-.0003"$
 Cutter Diameter: $+0"/-.005"$
 Flat: $+0"/-.005"$
 Radius: $\pm .003"$

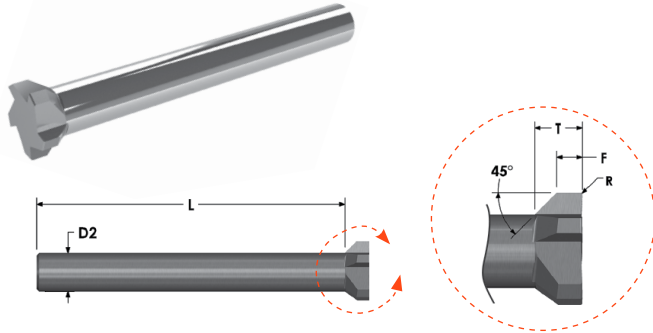

MTR Catalog No.	Cutter Diameter (D1)	Thickness (T)	Number of Flutes	Flat (F)	Radius (R)	Shank Length (L)
	inch	inch		inch	inch	inch
1/4" Shank – D2						
MTR-375	.375	9/32	4	.075	.010	2.500
5/16" Shank – D2						
MTR-500	.500	25/64	5	.100	.010	2.500
3/8" Shank – D2						
MTR-750	.750	1/4	6	.125	.015	2.500
1/2" Shank – D2						
MTR-001	1.000	1/4	7	.125	.015	3.000

For current pricing and availability please visit our website at www.micro100.com

FEATURING:

- Solid Carbide
- Suited for semi-finishing, finishing, and universal cutting applications in soft, medium and hard materials.

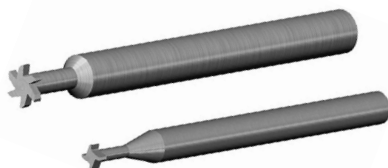

Tolerances:
 D2: $-.0001"/-0.0003"$
 D1: $+0"/-.0020"$
 W: $+0.001"/-0"$
 L2: $+0.010"/-0"$

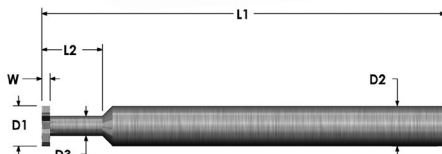

AITiN – Add “X” to the end of Catalog No.

KC Catalog No.	Cutter Diameter (D1)	Cutter Width (W)	Neck Diameter (D3)	Neck Length (L2)	Number of Flutes	Overall Length (L1)
	inch	inch	inch	inch		inch
1/8" Shanks – D2						
KC-093-140-010	.0938	.010	.047	.140	4	1.500
KC-093-140-015	.0938	.015	.047	.140	4	1.500
KC-093-140-020	.0938	.020	.047	.140	4	1.500
KC-093-140-025	.0938	.025	.047	.140	4	1.500
KC-093-140-030	.0938	.030	.047	.140	4	1.500
KC-093-140-040	.0938	.040	.047	.140	4	1.500
KC-125-190-010	.1250	.010	.062	.190	6	1.500
KC-125-190-015	.1250	.015	.062	.190	6	1.500
KC-125-190-020	.1250	.020	.062	.190	6	1.500
KC-125-190-025	.1250	.025	.062	.190	6	1.500
KC-125-190-030	.1250	.030	.062	.190	6	1.500
KC-125-190-035	.1250	.035	.062	.190	6	1.500
KC-125-190-040	.1250	.040	.062	.190	6	1.500
KC-125-190-045	.1250	.045	.062	.190	6	1.500
KC-125-190-050	.1250	.050	.062	.190	6	1.500
KC-125-190-055	.1250	.055	.062	.190	6	1.500
KC-125-190-060	.1250	.060	.062	.190	6	1.500
KC-125-190-062	.1250	.062	.062	.190	6	1.500
KC-125-190-093	.1250	.093	.062	.190	6	1.500
KC-125-375-030	.1250	.030	.062	.375	6	1.500
KC-125-375-062	.1250	.062	.062	.375	6	1.500
KC-125-375-093	.1250	.093	.062	.375	6	1.500
3/16" Shanks – D2						
KC-187-300-010	.1875	.010	.090	.300	6	2.000
KC-187-300-015	.1875	.015	.090	.300	6	2.000
KC-187-300-018	.1875	.018	.090	.300	6	2.000
KC-187-300-020	.1875	.020	.090	.300	6	2.000
KC-187-300-025	.1875	.025	.090	.300	6	2.000
KC-187-300-029	.1875	.029	.090	.300	6	2.000
KC-187-300-030	.1875	.030	.090	.300	6	2.000
KC-187-300-040	.1875	.040	.090	.300	6	2.000
KC-187-300-045	.1875	.045	.090	.300	6	2.000
KC-187-300-050	.1875	.050	.090	.300	6	2.000
KC-187-300-055	.1875	.055	.090	.300	6	2.000
KC-187-300-060	.1875	.060	.090	.300	6	2.000
KC-187-300-062	.1875	.062	.090	.300	6	2.000

FEATURING:

- Solid Carbide
- Suited for semi-finishing, finishing, and universal cutting applications in soft, medium and hard materials.

Page 274
for Coating
Info

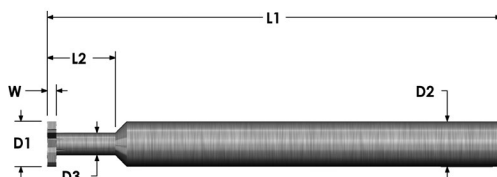
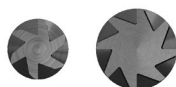
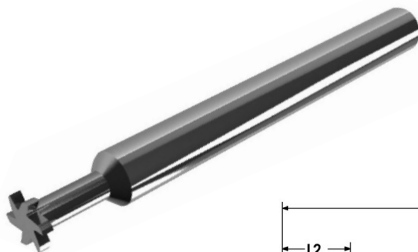

Tolerances:
D2: $-.0001"/-0.0003"$
D1: $+0"/-0.0020"$
W: $+0.001"/-0"$
L2: $+0.010"/-0"$

AiTIn – Add “X” to the end of Catalog No.

KC Catalog No.	Cutter Diameter (D1)	Cutter Width (W)	Neck Diameter (D3)	Neck Length (L2)	Number of Flutes	Overall Length (L1)
	inch	inch	inch	inch		inch
3/16" Shanks – D2						
KC-187-300-093	.1875	.093	.090	.300	6	2.000
KC-187-300-125	.1875	.125	.090	.300	6	2.000
KC-187-550-035	.1875	.035	.090	.550	6	2.000
KC-187-550-062	.1875	.062	.090	.550	6	2.000
KC-187-550-093	.1875	.093	.090	.550	6	2.000
KC-187-550-125	.1875	.125	.090	.550	6	2.000
1/4" Shanks – D2						
KC-250-375-015	.2500	.015	.125	.375	6	2.500
KC-250-375-020	.2500	.020	.125	.375	6	2.500
KC-250-375-025	.2500	.025	.125	.375	6	2.500
KC-250-375-030	.2500	.030	.125	.375	6	2.500
KC-250-375-035	.2500	.035	.125	.375	6	2.500
KC-250-375-040	.2500	.040	.125	.375	6	2.500
KC-250-375-045	.2500	.045	.125	.375	6	2.500
KC-250-375-050	.2500	.050	.125	.375	6	2.500
KC-250-375-055	.2500	.055	.125	.375	6	2.500
KC-250-375-060	.2500	.060	.125	.375	6	2.500
KC-250-375-062	.2500	.062	.125	.375	6	2.500
KC-250-375-093	.2500	.093	.125	.375	6	2.500
KC-250-375-125	.2500	.125	.125	.375	6	2.500
KC-250-750-030	.2500	.030	.125	.750	6	2.500
KC-250-750-062	.2500	.062	.125	.750	6	2.500
KC-250-750-093	.2500	.093	.125	.750	6	2.500
KC-250-750-125	.2500	.125	.125	.750	6	2.500
3/8" Shanks – D2						
KC-375-600-020	.3750	.020	.190	.600	8	2.500
KC-375-600-030	.3750	.030	.190	.600	8	2.500
KC-375-600-035	.3750	.035	.190	.600	8	2.500
KC-375-600-040	.3750	.040	.190	.600	8	2.500
KC-375-600-060	.3750	.060	.190	.600	8	2.500
KC-375-600-062	.3750	.062	.190	.600	8	2.500
KC-375-600-068	.3750	.068	.190	.600	8	2.500
KC-375-600-080	.3750	.080	.190	.600	8	2.500
KC-375-600-086	.3750	.086	.190	.600	8	2.500

For current pricing and availability please visit our website at www.micro100.com

FEATURING:

- Solid Carbide
- Suited for semi-finishing, finishing, and universal cutting applications in soft, medium and hard materials.

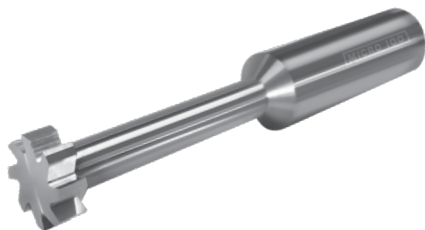

Tolerances:
 D2: $-.0001"/-.0003"$
 D1: $+0"/-.0020"$
 W: $+0.001"/-0"$
 L2: $+0.010"/-0"$

**Page 274
for Coating
Info**

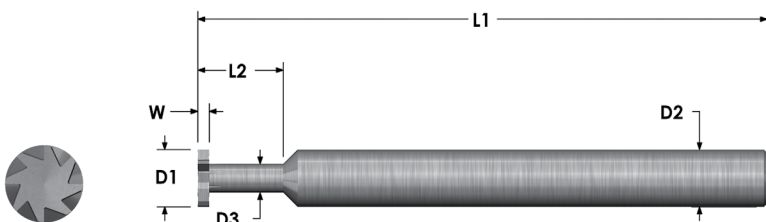

AlTiN – Add “X” to the end of Catalog No.

KC Catalog No.	Cutter Diameter (D1)	Cutter Width (W)	Neck Diameter (D3)	Neck Length (L2)	Number of Flutes	Overall Length (L1)
	inch	inch	inch	inch		inch
3/8" Shanks – D2						
KC-375-600-093	.3750	.093	.190	.600	8	2.500
KC-375-600-125	.3750	.125	.190	.600	8	2.500
KC-375-600-156	.3750	.156	.190	.600	8	2.500
KC-375-600-187	.3750	.187	.190	.600	8	2.500
KC-375-1125-062	.3750	.062	.190	1.125	8	2.500
KC-375-1125-093	.3750	.093	.190	1.125	8	2.500
KC-375-1125-156	.3750	.156	.190	1.125	8	2.500
KC-375-1125-187	.3750	.187	.190	1.125	8	2.500
1/2" Shanks – D2						
KC-500-750-030	.5000	.030	.250	.750	8	3.000
KC-500-750-035	.5000	.035	.250	.750	8	3.000
KC-500-750-040	.5000	.040	.250	.750	8	3.000
KC-500-750-060	.5000	.060	.250	.750	8	3.000
KC-500-750-062	.5000	.062	.250	.750	8	3.000
KC-500-750-093	.5000	.093	.250	.750	8	3.000
KC-500-750-103	.5000	.103	.250	.750	8	3.000
KC-500-750-118	.5000	.118	.250	.750	8	3.000
KC-500-750-120	.5000	.120	.250	.750	8	3.000
KC-500-750-125	.5000	.125	.250	.750	8	3.000
KC-500-750-156	.5000	.156	.250	.750	8	3.000
KC-500-750-187	.5000	.187	.250	.750	8	3.000
KC-500-750-250	.5000	.250	.250	.750	8	3.000
KC-500-1500-062	.5000	.062	.250	1.500	8	3.000
KC-500-1500-093	.5000	.093	.250	1.500	8	3.000
KC-500-1500-118	.5000	.118	.250	1.500	8	3.000
KC-500-1500-125	.5000	.125	.250	1.500	8	3.000
KC-500-1500-156	.5000	.156	.250	1.500	8	3.000
KC-500-1500-187	.5000	.187	.250	1.500	8	3.000
KC-500-1500-250	.5000	.250	.250	1.500	8	3.000

DT

30°, 60° & 90° Included Angle
Dovetail Cutters



FEATURING:

- One-piece, solid carbide tool.
- Corner radii enhance tool strength and rigidity.
- Engineered for superior rupture strength and exceptional machining versatility.

Page 274
for Coating
Info

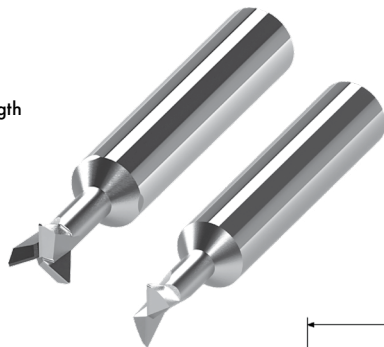

Tolerances:
D1: +0⁻/.002⁻
A: ±1°
L3: ± 1/32"
T.I.R. MAX: .0005"

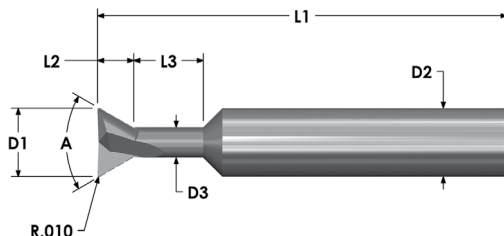

AiTIn – Add “X” to the end of Catalog No.

DT Catalog No.	Included Angle (A)	Cutter Diameter (D1)	Cutter Length (L2)	Neck Length (L3)	Neck Diameter (D3)	Number of Flutes	Overall Length (L1)
		inch	inch	inch	inch		inch
1/8" Shank Diameter							
DT-125-030-010	30°	.125	.095	1/8	.080	2	1.500
DT-125-060-010	60°	.125	.065	1/8	.065	2	1.500
DT-125-090-010	90°	.125	.042	1/8	.070	2	1.500
3/16" Shank Diameter							
DT-187-030-010	30°	.187	.127	1/8	.125	2	2.000
DT-187-060-010	60°	.187	.093	1/8	.095	2	2.000
DT-187-090-010	90°	.187	.048	1/8	.120	2	2.000
1/4" Shank Diameter							
DT-250-030-010	30°	.250	.161	1/8	.170	2	2.500
DT-250-060-010	60°	.250	.125	1/8	.120	2	2.500
DT-250-090-010	90°	.250	.064	1/8	.150	2	2.500
5/16" Shank Diameter							
DT-312-030-010	30°	.312	.221	5/16	.200	2	2.500
DT-312-060-010	60°	.312	.162	5/16	.140	2	2.500
DT-312-090-010	90°	.312	.095	5/16	.150	2	2.500
3/8" Shank Diameter							
DT-375-030-010	30°	.375	.263	3/8	.240	3	2.500
DT-375-060-010	60°	.375	.190	3/8	.170	3	2.500
DT-375-090-010	90°	.375	.127	3/8	.150	3	2.500
1/2" Shank Diameter							
DT-500-030-010	30°	.500	.347	1/2	.320	3	3.000
DT-500-060-010	60°	.500	.255	1/2	.220	3	3.000
DT-500-090-010	90°	.500	.164	1/2	.200	3	3.000

For current pricing and availability please visit our website at www.micro100.com

Tolerances:

Radius: $+.003"/-0"$

Overall Length: $\pm .015"$

Page 274
for Coating
Info

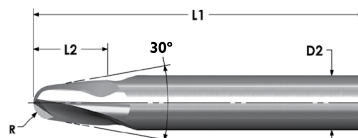
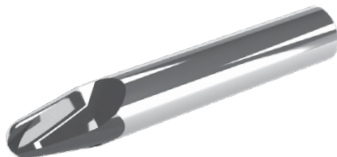

MRF Catalog No.	Number of Flutes	Flute Length (L2)	Radius (R)	Overall Length (L1)
		inch	inch	inch
3/16" Shanks – D2				
MRF-187-031	2	.262	1/32	2.000
MRF-187-046	2	.216	3/64	2.000
1/4" Shanks – D2				
MRF-250-062	2	.287	1/16	2.500
MRF-250-078	2	.243	5/64	2.500
5/16" Shanks – D2				
MRF-312-109	2	.270	7/64	2.500
3/8" Shanks – D2				
MRF-375-125 ♦	2	.341	1/8	2.500
1/2" Shanks – D2				
MRF-500-156 ♦	2	.545	5/32	3.000

Engineered to mill channels in molds

♦ WHILE SUPPLIES LAST - Discontinued

Tolerances:

Radius: $+.003"/-0"$

Overall Length: $\pm .015"$

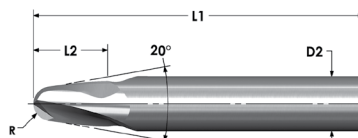
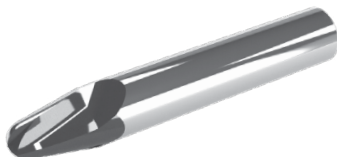

MRT Catalog No.	Number of Flutes	Flute Length (L2)	Radius (R)	Overall Length (L1)
		inch	inch	inch
3/16" Shanks – D2				
MRT-187-031	2	.383	1/32	2.000
MRT-187-046	2	.308	3/64	2.000
1/4" Shanks – D2				
MRT-250-062	2	.414	1/16	2.500
MRT-250-078	2	.338	5/64	2.500
5/16" Shanks – D2				
MRT-312-093	2	.437	3/32	2.500
MRT-312-109	2	.366	7/64	2.500
3/8" Shanks – D2				
MRT-375-125 ♦	2	.468	1/8	2.500
1/2" Shanks – D2				
MRT-500-156 ♦	2	.675	5/32	3.000

Engineered to mill channels in molds

♦ WHILE SUPPLIES LAST - Discontinued

Tolerances:
R: +.003"-0"
L1: T.I.R. MAX .0005"
Shank Diameter: -.0001" -.0003"

Page 274
for Coating
Info

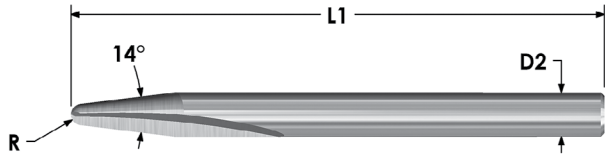

DSC Catalog No.	Number of Flutes	Radius (R)	Overall Length (L1)
		inch	inch
1/8" Shanks – D2			
DSC-125	2	.030	1.500
5/32" Shanks – D2			
DSC-156	2	.040	2.000
3/16" Shanks – D2			
DSC-187	2	.046	2.000
1/4" Shanks – D2			
DSC-250	2	.062	2.500
5/16" Shanks – D2			
DSC-312 ♦	2	.070	2.500
3/8" Shanks – D2			
DSC-375	2	.093	2.500
7/16" Shanks – D2			
DSC-437 ♦	2	.109	2.500
1/2" Shanks – D2			
DSC-500	2	.125	3.000

♦ WHILE SUPPLIES LAST - Discontinued

For current pricing and availability please visit our website at www.micro100.com

FEATURING:

- SFA style tools for applications in most aluminums and non-ferrous material.
- SFP and SFL style tools for applications in plastic and composite materials.
- Optimized rake and clearance angles to produce highest material removal rates and improved surface finishes.
- "O" flute design avoids chip melting and chip re-welding problems and evacuates chips efficiently.
- Open flute design with polished, mirror-like finish.
- Left-hand spiral routers are ideal for driving chips downward and for machining multi-layer workpieces that require downward cutting forces.
- Metric sizes available from stock.



SFA Style
for
Aluminum



SFL Style
Left-Hand Spiral for
Plastics/Composites

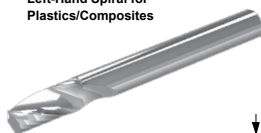

SFP Style
Right-Hand Spiral
for Plastics/Composites

Tolerances:
Cutter Diameter: +0⁻-.002"
Shank Diameter: -.0001"- .0003"
T.I.R. MAX: .0005"
Overall Length: ±.015"

Machine Plastic and Composite Materials!

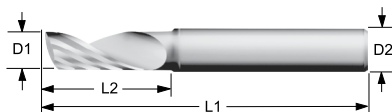

SFA Catalog No.	SFP Catalog No.	SFL Catalog No.	Cutter Diameter (D1) inch	Flute Length (L2) inch	Overall Length (L1) inch
1/8" Shanks – D2					
SFA-062-22	SFP-062-22	–	1/16	1/4	1.500
SFA-125-22	SFP-125-22	SFL-125-22	1/8	1/4	1.500
SFA-125-24	SFP-125-24	SFL-125-24	1/8	1/2	1.500
3/16" Shanks – D2					
SFA-187-33	SFP-187-33	SFL-187-33	3/16	1/2	2.000
SFA-187-35	SFP-187-35	SFL-187-35	3/16	5/8	2.000
1/4" Shanks – D2					
SFA-062-42	SFP-062-42	SFL-062-42	1/16	1/4	2.000
SFA-125-42	SFP-125-42	SFL-125-42	1/8	1/4	2.000
SFA-125-44	SFP-125-44	SFL-125-44	1/8	1/2	2.000
SFA-156-45	SFP-156-45	SFL-156-45	5/32	5/8	2.000
SFA-187-44	SFP-187-44	SFL-187-44 ♦	3/16	1/2	2.000
SFA-187-45	SFP-187-45	SFL-187-45	3/16	5/8	2.000
SFA-218-46	–	SFL-218-46 ♦	7/32	3/4	2.500
SFA-250-43	SFP-250-43	SFL-250-43	1/4	3/8	2.500
SFA-250-46	SFP-250-46	SFL-250-46	1/4	3/4	2.500
SFA-250-410	SFP-250-410	SFL-250-410	1/4	1-1/4	3.000
3/8" Shanks – D2					
SFA-375-69	SFP-375-69	SFL-375-69	3/8	1-1/8	3.000
1/2" Shanks – D2					
SFA-500-88	SFP-500-88	SFL-500-88 ♦	1/2	1	3.000
SFA-500-812	SFP-500-812	SFL-500-812	1/2	1-1/2	4.000

♦ WHILE SUPPLIES LAST - Discontinued

For current pricing and availability please visit our website at www.micro100.com

FEATURING:

- Ideal for routing printed circuit boards made from glass fiber, epoxy resin, and composites used in the aircraft industry.
- Equally effective for routing plastics and other non-metallic materials.
- The diamond-cut fluting pattern provides smooth, rapid cutting and leaves a clean edge.



Tolerances:
Cutter Diameter: +0⁻/-0.003"
T.I.R. MAX: .0005"
Overall Length: ±0.015"
Flute Length: +.030⁻/0"

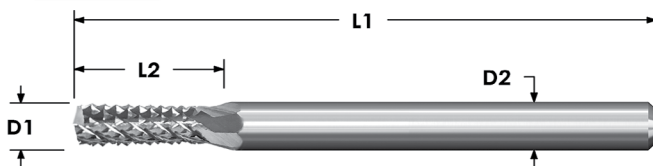

RDA
No End
Cut



RDB
Burr End
Cut



RDC
End Mill
End Cut



RDD
135° Drill
Point



RDE
Fish Tail
End Cut

RDA	RDB	RDC	RDD	RDE	Cutter Diameter (D1)	Flute Length (L2)	Overall Length (L1)
Catalog No.					inch	inch	inch
1/8" Shanks – D2							
RDA-10 ♦	RDB-10	–	RDD-10	–	1/16	3/16	1.500
RDA-20	RDB-20	RDC-20	RDD-20	RDE-20	3/32	3/8	1.500
RDA-30	RDB-30	RDC-30	RDD-30	RDE-30	1/8	1/2	1.500
3/16" Shanks – D2							
RDA-40	RDB-40	RDC-40	RDD-40	RDE-40	3/16	5/8	2.000
1/4" Shanks – D2							
RDA-50	RDB-50	RDC-50	RDD-50	RDE-50 ♦	3/16	5/8	2.000
RDA-60	RDB-60	RDC-60	RDD-60	RDE-60	1/4	3/4	2.000
RDA-70	RDB-70	RDC-70	RDD-70	RDE-70 ♦	1/4	3/4	2.500
RDA-80	RDB-80	RDC-80	RDD-80	RDE-80	1/4	1	3.000
5/16" Shanks – D2							
RDA-90 ♦	–	–	RDD-90 ♦	RDE-90 ♦	5/16	1	2.500
3/8" Shanks – D2							
RDA-100	RDB-100	–	–	RDE-100	3/8	1	2.500
1/2" Shanks – D2							
RDA-110	RDB-110	–	RDD-110	RDE-110	1/2	1	3.000

♦ WHILE SUPPLIES LAST - Discontinued

For current pricing and availability please visit our website at www.micro100.com

FEATURING:

- Double-ended, high performance solid carbide countersinking and chamfering tools can be utilized for countersinking, chamfering and deburring edges.
- Performs best where extreme high feed rates and longer tool life is needed.
- Ideally suited for aluminum, plastics, steels, stainless steels, titanium, and a wide variety of other materials.
- Not Center-Cutting.

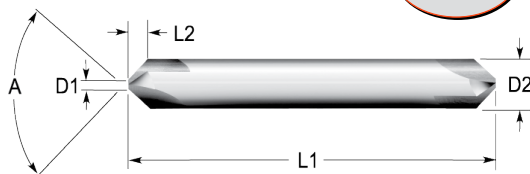

Tolerances:
Shank Diameter:
-.0001"/-.0003"
Included Angle: +1°

Page 274
for Coating
Info

C

AITiN – Add "X" to the end of Catalog No.

CS Catalog No.	Included Angle (A)	Non-Cutting Diameter (D1)	Length Of Cut (L2)	Number of Flutes	Overall Length (L1)
	degree	inch	inch		inch
1/8" Shanks – D2					
CS-125-060	60°	.030	.082	3	1.500
CS-125-082	82°	.030	.055	3	1.500
CS-125-090	90°	.030	.047	3	1.500
CS-125-100	100°	.030	.040	3	1.500
CS-125-120	120°	.030	.027	3	1.500
3/16" Shanks – D2					
CS-187-060	60°	.040	.128	4	2.000
CS-187-082	82°	.040	.085	4	2.000
CS-187-090	90°	.040	.074	4	2.000
CS-187-100	100°	.040	.062	4	2.000
CS-187-120	120°	.040	.043	4	2.000
1/4" Shanks – D2					
CS-250-060	60°	.050	.173	6	2.500
CS-250-082	82°	.050	.115	6	2.500
CS-250-090	90°	.050	.100	6	2.500
CS-250-100	100°	.050	.084	6	2.500
CS-250-120	120°	.050	.058	6	2.500
5/16" Shanks – D2					
CS-312-060	60°	.060	.219	6	2.500
CS-312-082	82°	.060	.145	6	2.500
CS-312-090	90°	.060	.126	6	2.500
CS-312-100	100°	.060	.106	6	2.500
CS-312-120	120°	.060	.073	6	2.500
3/8" Shanks – D2					
CS-375-060	60°	.070	.264	6	2.500
CS-375-082	82°	.070	.175	6	2.500
CS-375-090	90°	.070	.152	6	2.500
CS-375-100	100°	.070	.128	6	2.500
CS-375-120	120°	.070	.088	6	2.500
1/2" Shanks – D2					
CS-500-060	60°	.080	.364	6	3.000
CS-500-082	82°	.080	.242	6	3.000
CS-500-090	90°	.080	.210	6	3.000
CS-500-100	100°	.080	.176	6	3.000
CS-500-120	120°	.080	.121	6	3.000

Tolerances:
Pilot Diameter: $+.003"-0"$
Pilot Length: $\pm .015"-0"$
Shank Diameter: $-.0001"$ to $-.0003"$

**Page 274
for Coating
Info**

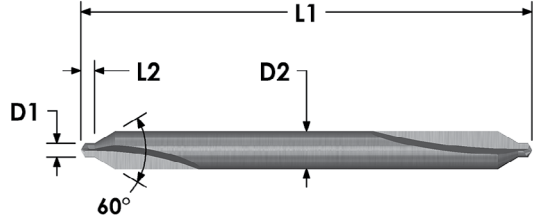
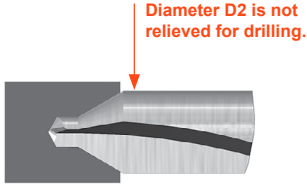
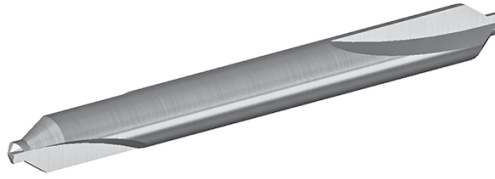

DC Catalog No.	Pilot Diameter (D1) inch	Pilot Length (L2) inch	Overall Length (L1) inch
1/8" Shank – D2			
DC-00	.025	1/32	1.500
DC-01	1/32	1/32	1.500
DC-1	3/64	3/64	1.500
3/16" Shank – D2			
DC-2	5/64	5/64	1.875
1/4" Shank – D2			
DC-3	7/64	7/64	2.000
5/16" Shank – D2			
DC-4	1/8	1/8	2.125
7/16" Shank – D2			
DC-5	3/16	3/16	2.750
1/2" Shank – D2			
DC-6	7/32	7/32	3.000



Combined Drill & Countersink Set

**Set Includes:
DC-1 through DC-6**

Catalog Set No. DC-0



For current pricing and availability please visit our website at www.micro100.com

Page 274
for Coating
Info



Tolerances:
L: ±.015"
W: ±.002"
Shank Diameter: -.0001" to -.0003"

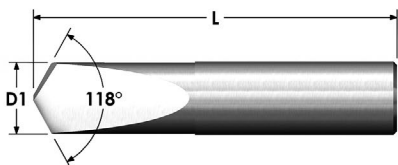

C

SD Catalog No.	Drill Diameter	Included Flute Taper (T)	Web Thickness (W)	Overall Length (L)
	inch		inch	
1/32" Shank Diameter - D2				
SD-031	1/32	6°	.010	1.250
1/16" Shank Diameter - D2				
SD-062	1/16	10°	.012	1.500
3/32" Shank Diameter - D2				
SD-093	3/32	10°	.016	1.500
1/8" Shank Diameter - D2				
SD-125	1/8	14°	.020	1.500
5/32" Shank Diameter - D2				
SD-156	5/32	16°	.025	2.000
3/16" Shank Diameter - D2				
SD-187	3/16	16°	.028	2.000
7/32" Shank Diameter - D2				
SD-218	7/32	18°	.030	2.000
1/4" Shank Diameter - D2				
SD-250	1/4	18°	.035	2.000
5/16" Shank Diameter - D2				
SD-312	5/16	18°	.040	2.500
3/8" Shank Diameter - D2				
SD-375	3/8	18°	.046	2.500
13/32" Shank Diameter - D2				
SD-406 ♦	13/32	20°	.048	2.500
7/16" Shank Diameter - D2				
SD-437 ♦	7/16	20°	.050	2.500
15/32" Shank Diameter - D2				
SD-468 ♦	15/32	21°	.055	2.500
1/2" Shank Diameter - D2				
SD-500	1/2	22°	.060	2.500

♦ WHILE SUPPLIES LAST - Discontinued

For current pricing and availability please visit our website at www.micro100.com

SPD

82°, 90°, 100° & 120° Included
Point Spotting & Centering Drills



Tolerances:

Shank Diameter: $-.0001''-.0003''$
Drill Diameter: $+0''-.0005''$
Maximum Drill Depth: $+.030''-0''$

Page 274
for Coating
Info

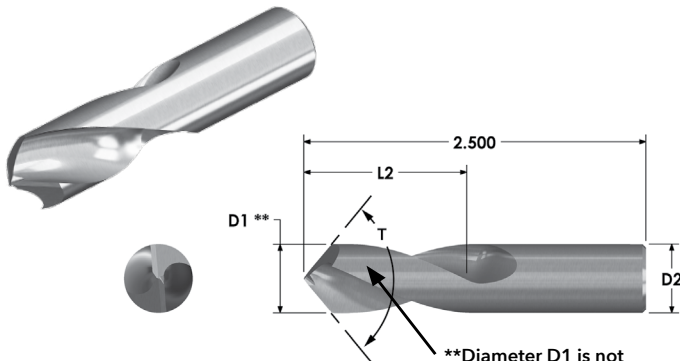

SPD Catalog No.	Cutter Diameter (D1)	Included Drill Point Angle (T)	Flute Length (L2)
	inch	degree	inch
1/4" Shank Diameter - D2			
SPD-250-082	1/4	82°	3/4
SPD-250-090	1/4	90°	3/4
SPD-250-100	1/4	100°	3/4
SPD-250-120	1/4	120°	3/4
5/16" Shank Diameter - D2			
SPD-312-082	5/16	82°	3/4
SPD-312-090	5/16	90°	3/4
SPD-312-100	5/16	100°	3/4
SPD-312-120	5/16	120°	3/4
3/8" Shank Diameter - D2			
SPD-375-082	3/8	82°	1
SPD-375-090	3/8	90°	1
SPD-375-100	3/8	100°	1
SPD-375-120	3/8	120°	1
1/2" Shank Diameter - D2			
SPD-500-082	1/2	82°	1
SPD-500-090	1/2	90°	1
SPD-500-100	1/2	100°	1
SPD-500-120	1/2	120°	1
5/8" Shank Diameter - D2			
SPD-625-082	5/8	82°	1-1/8
SPD-625-090	5/8	90°	1-1/8
SPD-625-100	5/8	100°	1-1/8
SPD-625-120	5/8	120°	1-1/8
3/4" Shank Diameter - D2			
SPD-750-082	3/4	82°	1-1/8
SPD-750-090	3/4	90°	1-1/8
SPD-750-100	3/4	100°	1-1/8
SPD-750-120	3/4	120°	1-1/8
1" Shank Diameter - D2			
SPD-001-090	1	90°	1-1/4
SPD-001-100	1	100°	1-1/4
SPD-001-120	1	120°	1-1/4

Page 274
for Coating
Info

Tolerances:
Drill Diameter: +0/-0.0005"
Maximum Drill Depth: +.030"/-0"
Shank Diameter: -.0001" to -.0003"

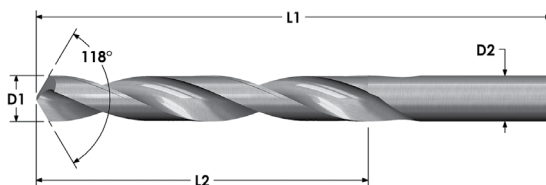

C

DR Catalog No.	Drill Diameter (D1) inch	Flute Length (L2) inch	Overall Length (L1) inch
1/32" Shank Diameter - D2			
DR-031-2	.0312	1/2	1.250
3/64" Shank Diameter - D2			
DR-046-2	.0469	3/4	1.500
1/16" Shank Diameter - D2			
DR-062-2	.0625	3/4	1.500
5/64" Shank Diameter - D2w			
DR-078-2	.0781	7/8	1.750
3/32" Shank Diameter - D2			
DR-093-2	.0938	1	2.000
7/64" Shank Diameter - D2			
DR-109-2	.1094	1-1/4	2.250
1/8" Shank Diameter - D2			
DR-125-2	.1250	1-1/4	2.250
3/16" Shank Diameter - D2			
DR-187-2	.1875	1-5/8	2.750
7/32" Shank Diameter - D2			
DR-218-2 ♦	.2188	1-3/4	3.000
1/4" Shank Diameter - D2			
DR-250-2	.2500	2	3.250
5/16" Shank Diameter - D2			
DR-312-2	.3125	2-3/8	3.750

♦ WHILE SUPPLIES LAST - Discontinued

For current pricing and availability please visit our website at www.micro100.com

RTC

Single and Double Ended, 30° Included Cut Angle, Engraving Tools.



Tolerances:

Point Offset: $\pm .001"$
 Overall Length: $\pm .015"$
 Shank Diameter: $-.0001"$ to $-.0003"$

Page 274
for Coating
Info

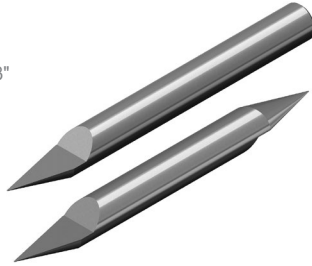

Ø 1/4" & Smaller Shank Styles

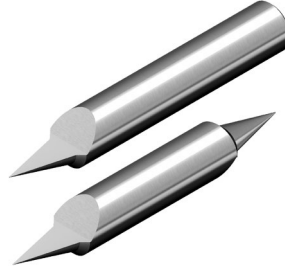

Ø 3/8" & Larger Shank Styles

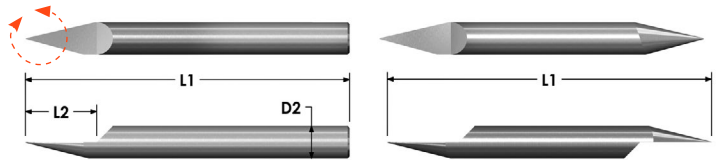
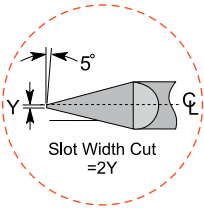

Relieved for Right-Hand cut

AITIN – Add "X" to the end of Catalog No.

Metric sizes also available.

RTC		Included Cut Angle	Split Face Length (L2)	Point Offset (Y)	Overall Length (L1)
SINGLE ENDED Catalog No.	DOUBLE ENDED Catalog No.				
1/8" Shanks – D2					
RTC-125-1	RTC-125-2	30°	3/8	.004	1.500
RTC-125-13	RTC-125-23	30°	3/8	.004	3.000
3/16" Shanks – D2					
RTC-187-1	RTC-187-2	30°	3/8	.004	2.000
RTC-187-13	RTC-187-23	30°	3/8	.004	3.000
1/4" Shanks – D2					
RTC-250-1	RTC-250-2	30°	3/8	.004	2.500
RTC-250-14	RTC-250-24	30°	3/8	.004	4.000
5/16" Shanks – D2					
RTC-312-1 ♦	RTC-312-2	30°	1/2	.004	2.500
RTC-312-14 ♦	RTC-312-24 ♦	30°	1/2	.004	4.000
3/8" Shanks – D2					
RTC-375-1	RTC-375-2	30°	1/2	.004	2.500
RTC-375-14	RTC-375-24	30°	1/2	.004	4.000
1/2" Shanks – D2					
RTC-500-1	RTC-500-2	30°	5/8	.004	3.000

♦ WHILE SUPPLIES LAST - Discontinued

For current pricing and availability please visit our website at www.micro100.com

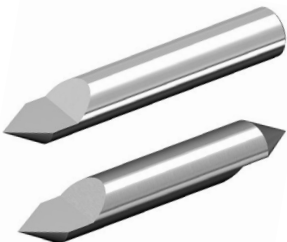

Tolerances:
Point Offset: $\pm 0.01"$
Overall Length: $\pm 0.15"$
Shank Diameter: $-0.001"$ to $-0.003"$

Page 274
for Coating
Info

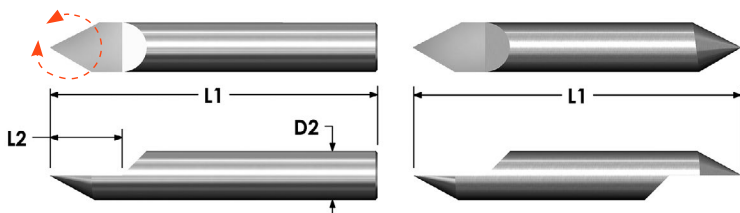
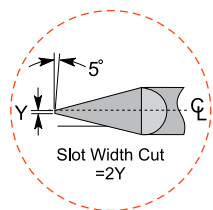

Relieved for Right-Hand cut

AITIN – Add “X” to the end of Catalog No.

Metric sizes also available.

RSC		Included Cut Angle	Split Face Length (L2)	Point Offset (Y)	Overall Length (L1)
SINGLE ENDED Catalog No.	DOUBLE ENDED Catalog No.				
1/8" Shanks – D2					
RSC-125-1	–	60°	3/8	.004	1.500
–	RSC-125-2	60°	3/8	.004	2.000
RSC-125-13	RSC-125-23	60°	3/8	.004	3.000
3/16" Shanks – D2					
RSC-187-1	RSC-187-2	60°	3/8	.004	2.000
RSC-187-13	RSC-187-23	60°	3/8	.004	3.000
1/4" Shanks – D2					
RSC-250-1	RSC-250-2	60°	3/8	.004	2.500
RSC-250-14	RSC-250-24	60°	3/8	.004	4.000
5/16" Shanks – D2					
RSC-312-1	RSC-312-2	60°	1/2	.004	2.500
RSC-312-14 ♦	RSC-312-24	60°	1/2	.004	4.000
3/8" Shanks – D2					
RSC-375-1	RSC-375-2	60°	1/2	.004	2.500
RSC-375-14 ♦	RSC-375-24	60°	1/2	.004	4.000
1/2" Shanks – D2					
RSC-500-1	RSC-500-2	60°	5/8	.004	3.000

♦ WHILE SUPPLIES LAST - Discontinued

RNC

Single and Double Ended, 90° Included Cut Angle Engraving Tools.



Tolerances:

Point Offset: $\pm .001"$

Overall Length: $\pm .015"$

Shank Diameter: $-.0001"$ to $-.0003"$

Page 274
for Coating
Info

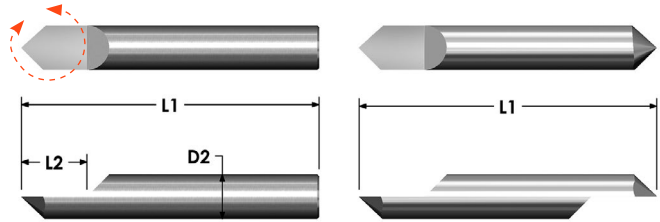
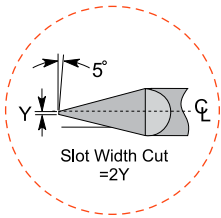
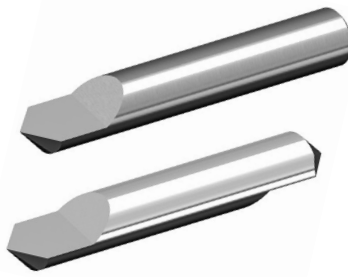

Relieved for
Right-Hand cut

AITin – Add "X" to the end of Catalog No.

Metric sizes also available.

RNC		Included Cut Angle	Split Face Length (L2)	Point Offset (Y)	Overall Length (L1)
SINGLE ENDED Catalog No.	DOUBLE ENDED Catalog No.				
			inch	inch	inch
1/8" Shanks – D2					
RNC-125-1	–	90°	3/8	.004	1.500
–	RNC-125-2	90°	3/8	.004	1.500
RNC-125-13	RNC-125-23	90°	3/8	.004	3.000
3/16" Shanks – D2					
RNC-187-1	RNC-187-2	90°	3/8	.004	2.000
RNC-187-13	RNC-187-23	90°	3/8	.004	3.000
1/4" Shanks – D2					
RNC-250-1	RNC-250-2	90°	3/8	.004	2.500
RNC-250-14	RNC-250-24	90°	3/8	.004	4.000
5/16" Shanks – D2					
RNC-312-1	RNC-312-2	90°	1/2	.004	2.500
–	RNC-312-24	90°	1/2	.004	4.000
3/8" Shanks – D2					
RNC-375-1	RNC-375-2	90°	1/2	.004	2.500
–	RNC-375-24	90°	1/2	.004	4.000
1/2" Shanks – D2					
RNC-500-1	RNC-500-2	90°	5/8	.004	3.000
–	RNC-500-24	90°	5/8	.004	4.000

For current pricing and availability please visit our website at www.micro100.com

Relieved for Right-Hand cut

AlTiN – Add “X” to the end of Catalog No.

Metric sizes also available.

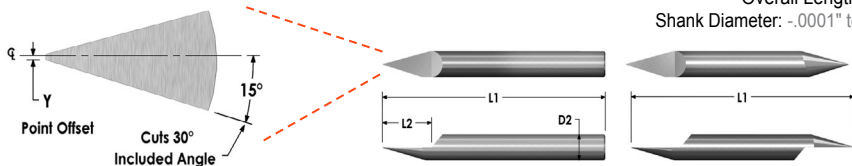

Tolerances:
Point Offset: $\pm .001$ "
Overall Length: $\pm .015$ "
Shank Diameter: $-.0001$ " to $-.0003$ "

RTC		Included Cut Angle	Split Face Length (L2)	Point Offset (Y)	Overall Length (L1)
SINGLE ENDED Catalog No.	DOUBLE ENDED Catalog No.				
1/4" Shanks – D2					
RTC-250-120	RTC-250-220	30°	1/2	.010	2.500
RTC-250-130	RTC-250-230	30°	1/2	.015	2.500
RTC-250-145 ♦	RTC-250-245 ♦	30°	1/2	.022	2.500
RTC-250-160 ♦	RTC-250-260 ♦	30°	1/2	.030	2.500

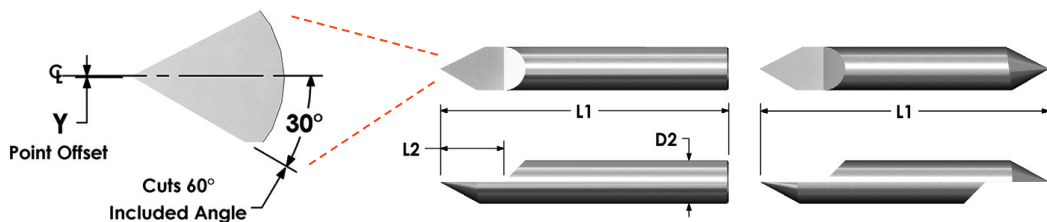

RSC		Included Cut Angle	Split Face Length (L2)	Point Offset (Y)	Overall Length (L1)
SINGLE ENDED Catalog No.	DOUBLE ENDED Catalog No.				
1/4" Shanks – D2					
RSC-250-120	RSC-250-220	60°	3/8	.010	2.500
RSC-250-130	RSC-250-230	60°	3/8	.015	2.500
RSC-250-145 ♦	–	60°	3/8	.022	2.500
RSC-250-160 ♦	RSC-250-260 ♦	60°	3/8	.030	2.500

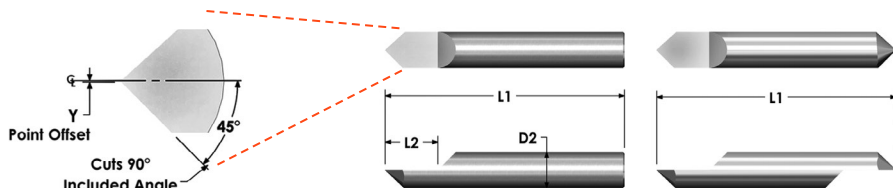

RNC		Included Cut Angle	Split Face Length (L2)	Point Offset (Y)	Overall Length (L1)
SINGLE ENDED Catalog No.	DOUBLE ENDED Catalog No.				
1/4" Shanks – D2					
–	RNC-250-220	90°	3/8	.010	2.500
RNC-250-130 ♦	RNC-250-230	90°	3/8	.015	2.500
RNC-250-145 ♦	–	90°	3/8	.022	2.500
RNC-250-160 ♦	RNC-250-260 ♦	90°	3/8	.030	2.500

♦ WHILE SUPPLIES LAST - Discontinued

Tolerances:
Split Length: +.015"/-.030"
Overall Length: ±.015"
Shank Diameter: -.0001" to -.0003"

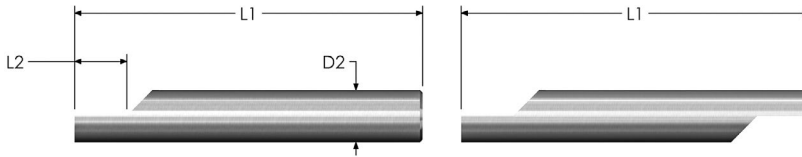
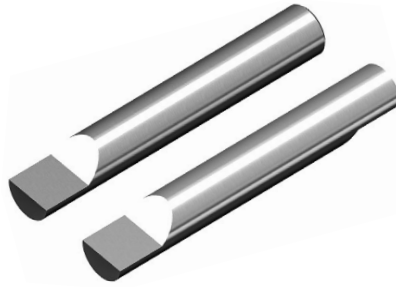

Metric sizes also available.

RS	RS	Face Length (L2)	Overall Length (L1)
SINGLE ENDED Catalog No.	DOUBLE ENDED Catalog No.	inch	inch
1/8" Shanks – D2			
RS-125-1	–	3/8	1.500
–	RS-125-2	3/8	2.000
RS-125-13	RS-125-23	3/8	3.000
3/16" Shanks – D2			
RS-187-1	RS-187-2	3/8	2.000
RS-187-13	RS-187-23	3/8	3.000
1/4" Shanks – D2			
RS-250-1	RS-250-2	3/8	2.500
RS-250-14	RS-250-24	3/8	4.000
5/16" Shanks – D2			
RS-312-1	RS-312-2	1/2	2.500
RS-312-14	RS-312-24	1/2	4.000
3/8" Shanks – D2			
RS-375-1	RS-375-2	1/2	2.500
RS-375-14	RS-375-24	1/2	4.000
1/2" Shanks – D2			
RS-500-1	RS-500-2	5/8	3.000
RS-500-14	RS-500-24	5/8	4.000

For current pricing and availability please visit our website at www.micro100.com

Tolerances:

Split Face Length: $+0.015/-0$ "

Overall Length: ± 0.015 "

Shank Diameter: -0.0001 " to -0.0003 "

Split Length in proportion to
length of tool.

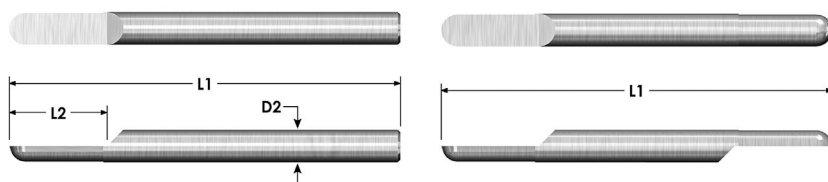
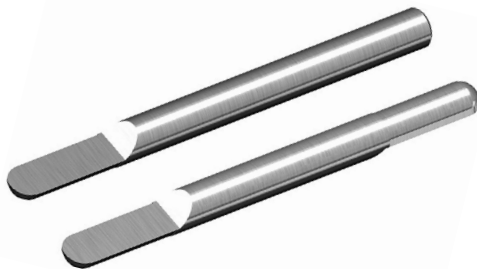

C

Metric sizes also available.

RSF	RSF	Face Length (L2)	Overall Length (L1)
SINGLE ENDED Catalog No.	DOUBLE ENDED Catalog No.	inch	inch
1/8" Shanks – D2			
RSF-125-1	–	3/8	1.500
–	RSF-125-2	3/8	1.500
–	RSF-125-23 ♦	3/8	3.000
3/16" Shanks – D2			
RSF-187-1	RSF-187-2	3/8	2.000
RSF-187-13 ♦	RSF-187-23 ♦	3/8	3.000
1/4" Shanks – D2			
RSF-250-1	RSF-250-2	3/8	2.500
RSF-250-14	–	3/8	4.000
5/16" Shanks – D2			
–	–	1/2	4.000
3/8" Shanks – D2			
RSF-375-1	RSF-375-2	1/2	2.500
1/2" Shanks – D2			
RSF-500-1	RSF-500-2	5/8	3.000

♦ WHILE SUPPLIES LAST - Discontinued

For current pricing and availability please visit our website at www.micro100.com

Tangential Blades

Slitting Blade



FEATURING:

- 40°, 50° & 60° Tangential Cutting Blades
- Suitable for sign makers, sail makers, and leather cutting applications.

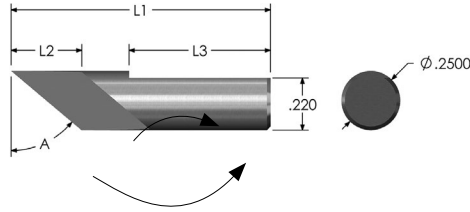

Tolerances:
 L1: ±.031"
 L2: ±.005"
 L3: ±.010"
 A: ±1°

C

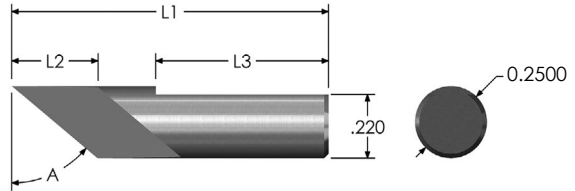

TANG-40 25pc minimum to re-sharp

TANG Catalog No.	Cutter Angle (A)	Cutter Length (L2)	Flat Length (L3)	Overall Length (L1)
		inch	inch	inch
TANG-40	40°	.250	.500	1.000
TANG-50	50°	.300	.600	1.100
TANG-60	60°	.433	.600	1.300

FEATURING:

- Suitable for sign makers, sail makers, and leather cutting applications.

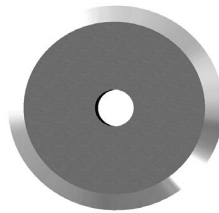

POLISHED EDGES

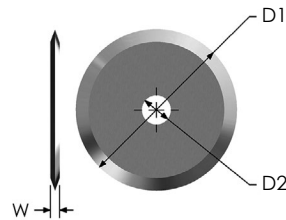

Tolerances:
 D1: ±.051mm
 Cutter Width: ±.025mm

PZ-1 50pc minimum to re-sharp

PZ Catalog No.	D1	W	D2
	mm	mm	mm
PZ-1	27.7	1.6	5

Call Micro 100 customer service for re-sharp details.

For current pricing and availability please visit our website at www.micro100.com

SPEEDY SHARP®

"THE ORIGINAL"

World's Fastest Sharpener!

SPEEDY SHARP IS...

The most universal sharpener ever manufactured!

It sharpens fast, is durable, and compact! Speedy Sharp is the most effective sharpener you will ever use.

It will literally sharpen anything with an edge from knives to lawn mower blades!

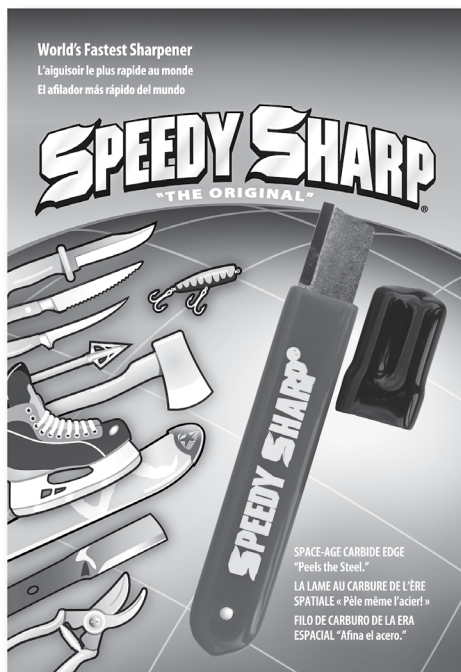

- Knives
 - Scissors
 - Chisels
 - Carpet Knives
 - Razor Blades
 - Broadhead Arrows
 - Fish Hooks
 - Serrated Knives
 - Axes
 - Router Bits
 - Planer Blades
 - Gardening Tools
 - Lawn Mower Blades...
- and much more!

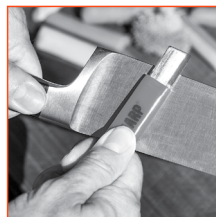

Catalog No. KS-1

www.SPEEDYSHARP.com

There are many brands of Micro-Grain Carbide Tools,
but there is only one...

MICRO 100[®]

Micro-Grain Carbide +Plus

C
your **SUPER CARBIDE TOOLS**
in a Class of their own!

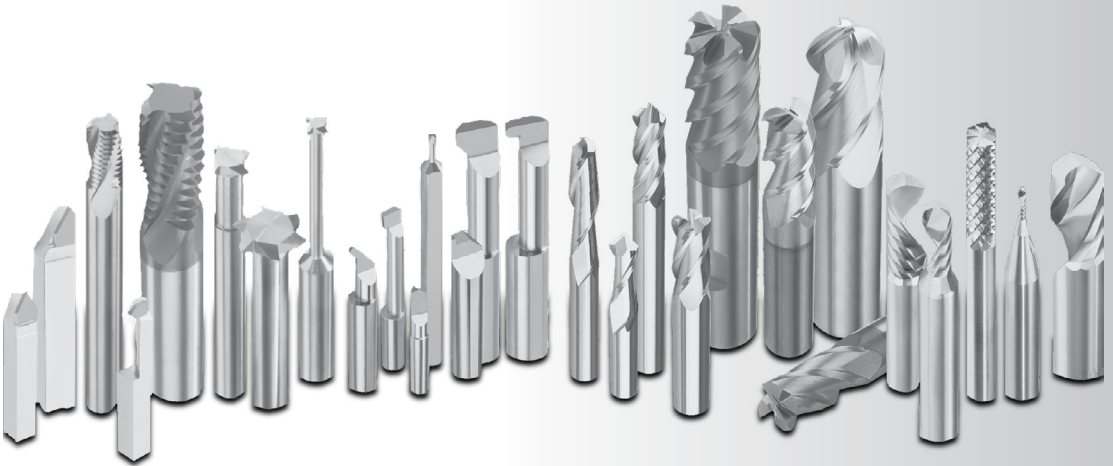

The Innovator of Solid Carbide Boring Tools

Superior rupture strength and highly shock resistant for
exceptional machining versatility.

*Proprietary Micro Grain Carbide
with the Highest Transverse
Rupture Strength*

MICRO 100®
super carbide tools

*is Unmatched in Toughness & Application
Versatility with Superior Material Removal
and Tool Life.*



D

Miniature End Mills

2, 3, 4, 5, & 6 flute Endmills

End Mills for Hard Milling Applications

Stub Length End Mills

the "SHREDDER"

the "V-HEMOTH"

Long Length End Mills

Mold Making End Mills

Corner Rounding End Mills

Tapered End Mills

Drill Mills

Ball Nose End Mills

Spherical Ball Nose End Mills



**WILL NOT CHIP OR BREAK
UNDER NORMAL MACHINING CONDITIONS**



Miniature End Mills

Styles for Hard Milling
pages 114 - 121



the "SHREDDER"

Styles SHL, SHR
page 136



Miniature End Mills

Styles RME & SME
page 160



The "V-HEMOTH" 4 flute

Styles VLR, VHS, VHM, VLM
pages 137, 139, 141, 143

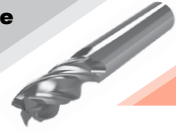

2 & 3 Flute End Mills

Style ASM, ARM, ARC
pages 122 - 124



The "V-HEMOTH" 5 flute

Styles VLR, VHS, VHM
pages 138, 140, 142

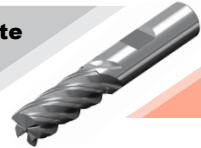

2/3/4 Flute End Mills

Styles GEM, GEC, EMS, SEM
pages 126 - 130

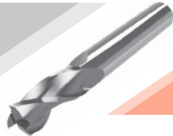

Long Length End Mills

Styles GEL, GLR
pages 144, 145

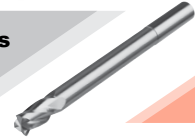

3 & 4 Flute End Mills

Style SDH
page 131

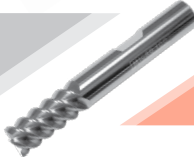

Tapered End Mills

Style TSM
page 146

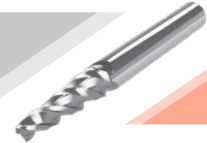

5 Flute End Mills

Styles ASM, ARM, ARC
pages 122 - 124



Corner Rounding End Mills

Style CRE
page 147

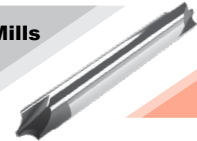

6 Flute End Mills

Style EMH
page 135

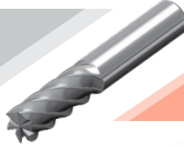

Drill Mills

Style DM
page 148



Miniature Ball Nose End Mills

Styles BEF for Hard Milling
pages 149 - 151



Long Length Ball Nose End Mills

Styles BLR & BEL
pages 155, 158



Miniature Ball Nose End Mills

Styles BMR & BMS
pages 152, 153



2/3 Flute Ball Nose End Mills

Styles ARB
page 154



2/3/4 Flute Ball Nose End Mills

Style BEM
pages 156, 157



Ball Nose End Mills

Style SBM
page 159

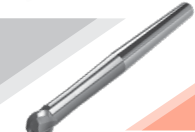

FEATURING:

- These precision miniature end mills are ideal for finishing and semi-finishing cuts and universal milling applications in soft, medium and hard materials.

Tolerances:
Shank Diameter: $-.0001"-.0003"$
Cutter Diameter: $\pm .0005"$
T.I.R. MAX: $.0005"$

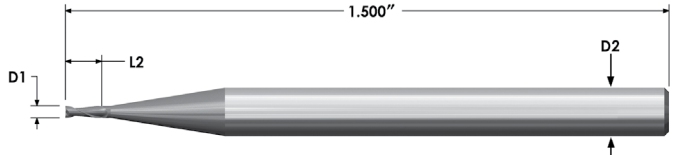
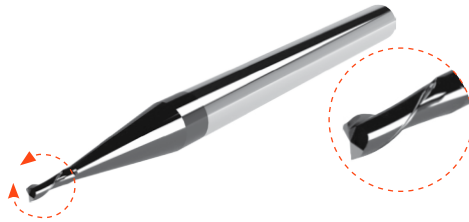

AITiN – Add “X” to the end of Catalog No.

Metric sizes also available.

RME	Cutter Diameter (D1)	Flute Length (L2)
2 FLUTE		
Catalog No.	inch	inch
1/8" Shanks – D2		
RME-010-2	.010	.030
RME-011-2	.011	.033
RME-012-2	.012	.036
RME-013-2	.013	.039
RME-014-2	.014	.042
RME-015-2	.015	.045
RME-016-2	.016	.048
RME-017-2	.017	.051
RME-018-2	.018	.054
RME-019-2	.019	.057
RME-020-2	.020	.060
RME-021-2	.021	.063
RME-022-2	.022	.066
RME-023-2	.023	.069
RME-024-2	.024	.072
RME-025-2	.025	.075
RME-026-2 ♦	.026	.078
RME-027-2	.027	.081
RME-028-2	.028	.084
RME-029-2	.029	.087
RME-030-2	.030	.090
RME-031-2	.031	.093
RME-032-2	.032	.096
RME-033-2 ♦	.033	.099
RME-034-2	.034	.102
RME-035-2	.035	.105
RME-040-2	.040	.120
RME-045-2	.045	.135
RME-050-2	.050	.150

SME	Cutter Diameter (D1)	Flute Length (L2)
2 FLUTE		
Catalog No.	inch	inch
1/8" Shanks – D2		
SME-005-2	.005	.007
SME-006-2	.006	.009
SME-007-2	.007	.010
SME-008-2	.008	.012
SME-009-2	.009	.013
SME-010-2	.010	.015
SME-011-2 ♦	.011	.016
SME-012-2	.012	.018
SME-013-2	.013	.019
SME-014-2	.014	.021
SME-015-2	.015	.022
SME-016-2	.016	.024
SME-017-2	.017	.025
SME-018-2	.018	.027
SME-019-2	.019	.028
SME-020-2	.020	.030
SME-022-2	.022	.033
SME-023-2	.023	.034
SME-025-2	.025	.037
SME-026-2	.026	.039
SME-027-2	.027	.040
SME-028-2	.028	.042
SME-029-2	.029	.043
SME-030-2	.030	.045
SME-031-2	.031	.047
SME-032-2 ♦	.032	.048
SME-033-2	.033	.050
SME-034-2 ♦	.034	.051
SME-035-2	.035	.053
SME-040-2	.040	.060
SME-045-2	.045	.068
SME-050-2	.050	.075

♦ WHILE SUPPLIES LAST - Discontinued

MEF

2 & 3 Flute, Extra Fine Carbide,
Hard Milling, Miniature
End Mills



FEATURING:

- These precision miniature end mills are ideal for finishing and semi-finishing cuts and universal milling applications in soft, medium and hard materials.
- 1.5x to 12x Reach Lengths.
- Machine Hardened Materials 45-68 Rc
- Extra Fine Carbide End Mills Engineered for Hard Milling Applications.

Page 274
for Coating
Info

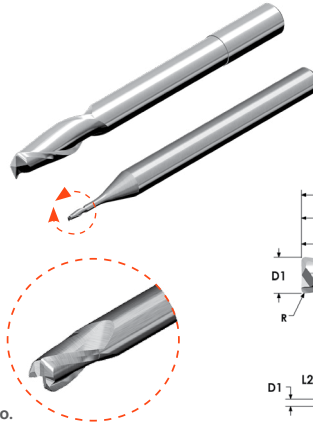

Tolerances:
Shank Diameter: $-.0001''$ - $-.0003''$
Cutter Diameter: $0''$ - $.0005''$
T.I.R. MAX: $.0005''$

Longer necks are
reduced neck

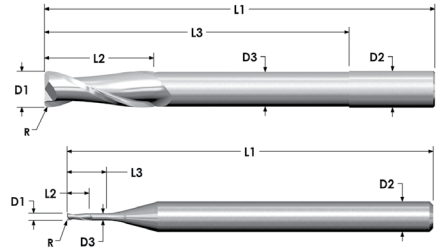

nACRo® – Add “K” to the end of Catalog No.
Metric sizes also available.

MEF		Cutter Diameter (D1)	Flute Length (L2)	Overall Reach (L3)	Neck Diameter (D3)	Tool Radius (R)	Overall Length (L1)
2 FLUTE Catalog No.	3 FLUTE Catalog No.	inch	inch	inch	inch	inch	inch
1/8" Shanks – D2							
MEF-010-015	MEF-010-015-3	.0100	.015	.015	.010	.000	1.500
MEF-010-050	MEF-010-050-3	.0100	.015	.050	.009	.000	1.500
MEF-010-075	MEF-010-075-3	.0100	.015	.075	.009	.000	1.500
MEF-015-023	MEF-015-023-3	.0150	.023	.023	.015	.000	1.500
MEF-015-100	MEF-015-100-3	.0150	.023	.100	.014	.000	1.500
MEF-015-200	MEF-015-200-3	.0150	.023	.200	.014	.000	1.500
MEF-015-023-002	MEF-015-023-3-002	.0150	.023	.023	.015	.002	1.500
MEF-015-100-002	MEF-015-100-3-002	.0150	.023	.100	.014	.002	1.500
MEF-015-200-002	MEF-015-200-3-002	.0150	.023	.200	.014	.002	1.500
MEF-020-030	MEF-020-030-3	.0200	.030	.030	.020	.000	1.500
MEF-020-150	MEF-020-150-3	.0200	.030	.150	.014	.000	1.500
MEF-020-250	MEF-020-250-3	.0200	.030	.250	.014	.000	1.500
MEF-020-030-002	MEF-020-030-3-002	.0200	.030	.030	.020	.002	1.500
MEF-020-150-002	MEF-020-150-002	.0200	.030	.150	.019	.002	1.500
MEF-020-250-002	MEF-020-250-3-002	.0200	.030	.250	.019	.002	1.500
MEF-025-038	MEF-025-038-3	.0250	.038	.038	.025	.003	1.500
MEF-025-150	MEF-025-150-3	.0250	.038	.150	.024	.003	1.500
MEF-025-250	MEF-025-250-3	.0250	.038	.250	.024	.003	1.500
MEF-025-038-003	MEF-025-038-3-003	.0250	.038	.038	.025	.003	1.500
MEF-025-150-003	MEF-025-150-3-003	.0250	.038	.150	.024	.003	1.500
MEF-025-250-003	MEF-025-250-3-003	.0250	.038	.250	.024	.003	1.500
MEF-030-045	MEF-030-045-3	.0300	.045	.045	.030	.000	1.500
MEF-030-100	MEF-030-100-3	.0300	.045	.100	.028	.000	1.500
MEF-030-200	MEF-030-200-3	.0300	.045	.200	.028	.000	1.500
MEF-030-375	MEF-030-375-3	.0300	.045	.375	.028	.000	1.500
MEF-030-045-005	MEF-030-045-3-005	.0300	.045	.045	.030	.005	1.500
MEF-030-045-010	MEF-030-045-3-010	.0300	.045	.045	.030	.010	1.500
MEF-030-100-005	MEF-030-100-3-005	.0300	.045	.100	.028	.005	1.500
MEF-030-100-010	MEF-030-100-3-010	.0300	.045	.100	.028	.010	1.500
MEF-030-200-005	MEF-030-200-3-005	.0300	.045	.200	.028	.005	1.500
MEF-030-200-010	MEF-030-200-3-010	.0300	.045	.200	.028	.010	1.500
MEF-030-375-005	MEF-030-375-3-005	.0300	.045	.375	.028	.005	1.500
MEF-030-375-010	MEF-030-375-3-010	.0300	.045	.375	.028	.010	1.500

FEATURING:

- These precision miniature end mills are ideal for finishing and semi-finishing cuts and universal milling applications in soft, medium and hard materials.
- 1.5x to 12x Reach Lengths.
- Machine Hardened Materials 45-68 Rc
- Extra Fine Carbide End Mills Engineered for Hard Milling Applications.

Page 274
for Coating
Info

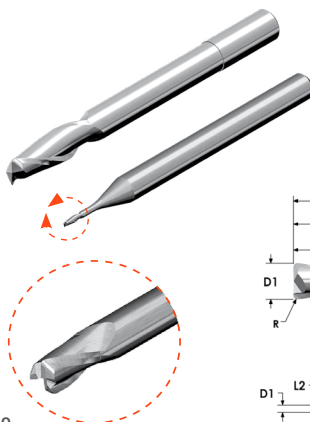

Tolerances:
Shank Diameter: $-.0001" - .0003"$
Cutter Diameter: $0" - .0005"$
T.I.R. MAX: $.0005"$

Longer necks are reduced neck

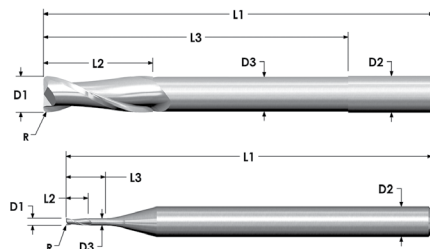

nAcRo® – Add “K” to the end of Catalog No.
Metric sizes also available.

MEF		Cutter Diameter (D1)	Flute Length (L2)	Overall Reach (L3)	Neck Diameter (D3)	Tool Radius (R)	Overall Length (L1)
2 FLUTE Catalog No.	3 FLUTE Catalog No.						
1/8" Shanks – D2		inch	inch	inch	inch	inch	inch
MEF-031-047	MEF-031-047-3	.0310	.047	.047	.031	.000	1.500
MEF-031-100	MEF-031-100-3	.0310	.047	.100	.029	.000	1.500
MEF-031-200	MEF-031-200-3	.0310	.047	.200	.029	.000	1.500
MEF-031-375	MEF-031-375-3	.0310	.047	.375	.029	.000	1.500
MEF-031-047-005	MEF-031-047-3-005	.0310	.047	.047	.031	.005	1.500
MEF-031-047-010	MEF-031-047-3-010	.0310	.047	.047	.031	.010	1.500
MEF-031-100-005	MEF-031-100-3-005	.0310	.047	.100	.029	.005	1.500
MEF-031-100-010	MEF-031-100-3-010	.0310	.047	.100	.029	.010	1.500
MEF-031-200-005	MEF-031-200-3-005	.0310	.047	.200	.029	.005	1.500
MEF-031-200-010	MEF-031-200-3-010	.0310	.047	.200	.029	.010	1.500
MEF-031-375-005	MEF-031-375-3-005	.0310	.047	.375	.029	.005	1.500
MEF-031-375-010	MEF-031-375-3-010	.0310	.047	.375	.029	.010	1.500
MEF-035-053	MEF-035-053-3	.0350	.053	.053	.035	.000	1.500
MEF-035-150	MEF-035-150-3	.0350	.053	.150	.033	.000	1.500
MEF-035-250	MEF-035-250-3	.0350	.053	.250	.033	.000	1.500
MEF-035-400	MEF-035-400-3	.0350	.053	.400	.033	.000	1.500
MEF-035-053-005	MEF-035-053-3-005	.0350	.053	.053	.035	.005	1.500
MEF-035-053-010	MEF-035-053-3-010	.0350	.053	.053	.035	.010	1.500
MEF-035-150-005	MEF-035-150-3-005	.0350	.053	.150	.033	.005	1.500
MEF-035-150-010	MEF-035-150-3-010	.0350	.053	.150	.033	.010	1.500
MEF-035-250-005	MEF-035-250-3-005	.0350	.053	.250	.033	.005	1.500
MEF-035-250-010	MEF-035-250-3-010	.0350	.053	.250	.033	.010	1.500
MEF-035-400-005	MEF-035-400-3-005	.0350	.053	.400	.033	.005	1.500
MEF-035-400-010	MEF-035-400-3-010	.0350	.053	.400	.033	.010	1.500
MEF-040-060	MEF-040-060-3	.0400	.060	.060	.040	.000	1.500
MEF-040-150	MEF-040-150-3	.0400	.060	.150	.038	.000	1.500
MEF-040-250	MEF-040-250-3	.0400	.060	.250	.038	.000	1.500
MEF-040-500	MEF-040-500-3	.0400	.060	.500	.038	.000	1.500
MEF-040-060-005	MEF-040-060-3-005	.0400	.060	.060	.040	.005	1.500
MEF-040-060-010	MEF-040-060-3-010	.0400	.060	.060	.040	.010	1.500
MEF-040-150-005	MEF-040-150-3-005	.0400	.060	.150	.038	.005	1.500
MEF-040-150-010	MEF-040-150-3-010	.0400	.060	.150	.038	.010	1.500
MEF-040-250-005	MEF-040-250-3-005	.0400	.060	.250	.038	.005	1.500

MEF

2 & 3 Flute, Extra Fine Carbide,
Hard Milling, Miniature
End Mills



FEATURING:

- These precision miniature end mills are ideal for finishing and semi-finishing cuts and universal milling applications in soft, medium and hard materials.
- 1.5x to 12x Reach Lengths.
- Machine Hardened Materials 45-68 Rc
- Extra Fine Carbide End Mills Engineered for Hard Milling Applications.

Page 274
for Coating
Info

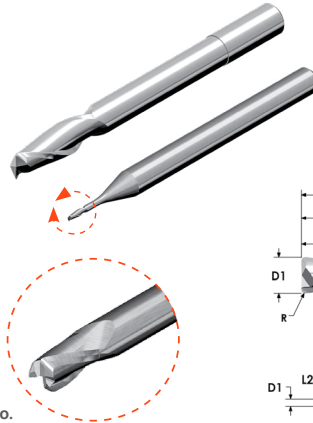

Tolerances:
Shank Diameter: $-.0001''$ - $-.0003''$
Cutter Diameter: $0''$ - $-.0005''$
T.I.R. MAX: $.0005''$
Longer necks are reduced neck

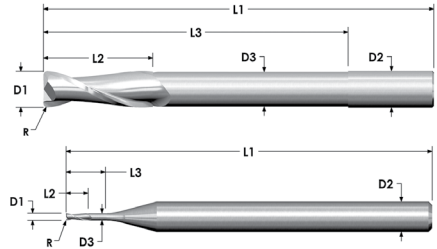

nACRo® – Add “K” to the end of Catalog No.
Metric sizes also available.

MEF		Cutter Diameter (D1)	Flute Length (L2)	Overall Reach (L3)	Neck Diameter (D3)	Tool Radius (R)	Overall Length (L1)
2 FLUTE Catalog No.	3 FLUTE Catalog No.	inch	inch	inch	inch	inch	inch
1/8" Shanks – D2							
MEF-040-250-010	MEF-040-250-3-010	.0400	.060	.250	.038	.010	1.500
MEF-040-500-005	MEF-040-500-3-005	.0400	.060	.500	.038	.005	1.500
MEF-040-500-010	MEF-040-500-3-010	.0400	.060	.500	.038	.010	1.500
MEF-045-068	MEF-045-068-3	.0450	.068	.068	.043	.000	1.500
MEF-045-150	MEF-045-150-3	.0450	.068	.150	.043	.000	1.500
MEF-045-250	MEF-045-250-3	.0450	.068	.250	.043	.000	1.500
MEF-045-500	MEF-045-500-3	.0450	.068	.500	.043	.000	1.500
MEF-045-068-005	MEF-045-068-3-005	.0450	.068	.068	.043	.005	1.500
MEF-045-068-010	MEF-045-068-3-010	.0450	.068	.068	.043	.010	1.500
MEF-045-150-005	MEF-045-150-3-005	.0450	.068	.150	.043	.005	1.500
MEF-045-150-010	MEF-045-150-3-010	.0450	.068	.150	.043	.010	1.500
MEF-045-250-005	MEF-045-250-3-005	.0450	.068	.250	.043	.005	1.500
MEF-045-250-010	MEF-045-250-3-010	.0450	.068	.250	.043	.010	1.500
MEF-045-500-005	MEF-045-500-3-005	.0450	.068	.500	.043	.005	1.500
MEF-045-500-010	MEF-045-500-3-010	.0450	.068	.500	.043	.010	1.500
MEF-047-071	MEF-047-071-3	.0470	.071	.071	.047	.000	1.500
MEF-047-150	MEF-047-150-3	.0470	.071	.150	.045	.000	1.500
MEF-047-250	MEF-047-250-3	.0470	.071	.250	.045	.000	1.500
MEF-047-500	MEF-047-500-3	.0470	.071	.500	.045	.000	1.500
MEF-047-071-005	MEF-047-071-3-005	.0470	.071	.071	.047	.005	1.500
MEF-047-071-010	MEF-047-071-3-010	.0470	.071	.071	.047	.010	1.500
MEF-047-150-005	MEF-047-150-3-005	.0470	.071	.150	.045	.005	1.500
MEF-047-150-010	MEF-047-150-3-010	.0470	.071	.150	.045	.010	1.500
MEF-047-250-005	MEF-047-250-3-005	.0470	.071	.250	.045	.005	1.500
MEF-047-250-010	MEF-047-250-3-010	.0470	.071	.250	.045	.010	1.500
MEF-047-500-005	MEF-047-500-3-005	.0470	.071	.500	.045	.005	1.500
MEF-047-500-010	MEF-047-500-3-010	.0470	.071	.500	.045	.010	1.500
MEF-050-075	MEF-050-075-3	.0500	.075	.075	.050	.000	1.500
MEF-050-200	MEF-050-200-3	.0500	.075	.200	.048	.000	1.500
MEF-050-300	MEF-050-300-3	.0500	.075	.300	.048	.000	1.500
MEF-050-550	MEF-050-550-3	.0500	.075	.550	.048	.000	1.500
MEF-050-075-005	MEF-050-075-3-005	.0500	.075	.075	.050	.005	1.500
MEF-050-075-010	MEF-050-075-3-010	.0500	.075	.075	.050	.010	1.500

FEATURING:

- These precision miniature end mills are ideal for finishing and semi-finishing cuts and universal milling applications in soft, medium and hard materials.
- 1.5x to 12x Reach Lengths.
- Machine Hardened Materials 45-68 Rc
- Extra Fine Carbide End Mills Engineered for Hard Milling Applications.

Page 274 for Coating Info

nAcRo® – Add “K” to the end of Catalog No.
Metric sizes also available.

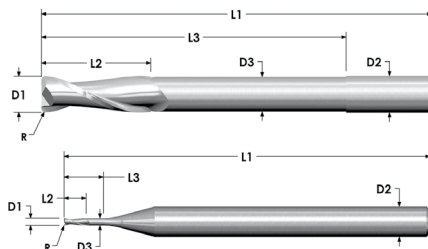
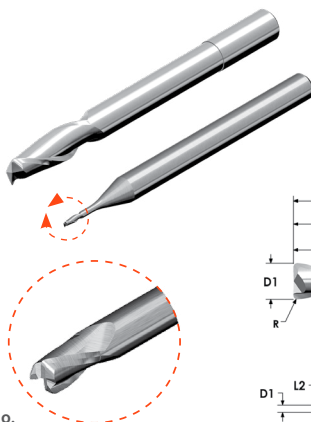

Tolerances:
Shank Diameter: -.0001"-.0003"
Cutter Diameter: 0" - .0005"
T.I.R. MAX: .0005"
Longer necks are reduced neck

MEF		Cutter Diameter (D1)	Flute Length (L2)	Overall Reach (L3)	Neck Diameter (D3)	Tool Radius (R)	Overall Length (L1)
2 FLUTE Catalog No.	3 FLUTE Catalog No.	inch	inch	inch	inch	inch	inch
1/8" Shanks – D2							
MEF-050-200-005	MEF-050-200-3-005	.0500	.075	.200	.048	.005	1.500
MEF-050-200-010	MEF-050-200-3-010	.0500	.075	.200	.048	.010	1.500
MEF-050-300-005	MEF-050-300-3-005	.0500	.075	.300	.048	.005	1.500
MEF-050-300-010	MEF-050-300-3-010	.0500	.075	.300	.048	.010	1.500
MEF-050-550-005	MEF-050-550-3-005	.0500	.075	.550	.048	.005	1.500
MEF-050-550-010	MEF-050-550-3-010	.0500	.075	.550	.048	.010	1.500
MEF-060-090	MEF-060-090-3	.0600	.090	.090	.060	.000	1.500
MEF-060-200	MEF-060-200-3	.0600	.090	.200	.056	.000	1.500
MEF-060-350	MEF-060-350-3	.0600	.090	.350	.056	.000	1.500
MEF-060-500	MEF-060-500-3	.0600	.090	.500	.056	.000	1.500
MEF-060-750	MEF-060-750-3	.0600	.090	.750	.056	.000	2.000
MEF-060-090-005	MEF-060-090-3-005	.0600	.090	.090	.060	.005	1.500
MEF-060-090-010	MEF-060-090-3-010	.0600	.090	.090	.060	.010	1.500
MEF-060-090-015	MEF-060-090-3-015	.0600	.090	.090	.060	.015	1.500
MEF-060-200-005	MEF-060-200-3-005	.0600	.090	.200	.056	.005	1.500
MEF-060-200-010	MEF-060-200-3-010	.0600	.090	.200	.056	.010	1.500
MEF-060-200-015	MEF-060-200-3-015	.0600	.090	.200	.056	.015	1.500
MEF-060-350-005	MEF-060-350-3-005	.0600	.090	.350	.056	.005	1.500
MEF-060-350-010	MEF-060-350-3-010	.0600	.090	.350	.056	.010	1.500
MEF-060-350-015	MEF-060-350-3-015	.0600	.090	.350	.056	.015	1.500
MEF-060-500-005	MEF-060-500-3-005	.0600	.090	.500	.056	.005	1.500
MEF-060-500-010	MEF-060-500-3-010	.0600	.090	.500	.056	.010	1.500
MEF-060-500-015	MEF-060-500-3-015	.0600	.090	.500	.056	.015	1.500
MEF-060-750-005	MEF-060-750-3-005	.0600	.090	.750	.056	.005	2.000
MEF-060-750-010	MEF-060-750-3-010	.0600	.090	.750	.056	.010	2.000
MEF-060-750-015	MEF-060-750-3-015	.0600	.090	.750	.056	.015	2.000
MEF-062-093	MEF-062-093-3	.0625	.093	.093	.062	.000	1.500
MEF-062-200	MEF-062-200-3	.0625	.093	.200	.058	.000	1.500
MEF-062-350	MEF-062-350-3	.0625	.093	.350	.058	.000	1.500
MEF-062-550	MEF-062-550-3	.0625	.093	.550	.058	.000	1.500
MEF-062-750	MEF-062-750-3	.0625	.093	.750	.058	.000	2.000
MEF-062-093-005	MEF-062-093-3-005	.0625	.093	.093	.058	.005	1.500
MEF-062-093-010	MEF-062-093-3-010	.0625	.093	.093	.062	.010	1.500

MEF

2 & 3 Flute, Extra Fine Carbide, Hard Milling, Miniature End Mills



FEATURING:

- These precision miniature end mills are ideal for finishing and semi-finishing cuts and universal milling applications in soft, medium and hard materials.
- 1.5x to 12x Reach Lengths.
- Machine Hardened Materials 45-68 Rc
- Extra Fine Carbide End Mills Engineered for Hard Milling Applications.

Page 274 for Coating Info

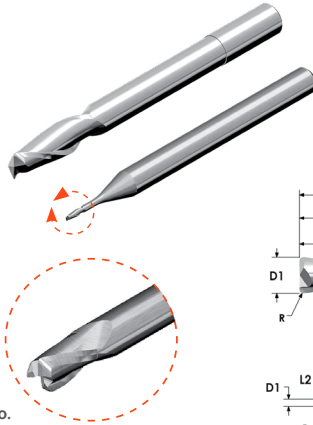

Tolerances:
 Shank Diameter: $-.0001''$ - $-.0003''$
 Cutter Diameter: $0''$ - $-.0005''$
 T.I.R. MAX: $.0005''$
Longer necks are reduced neck

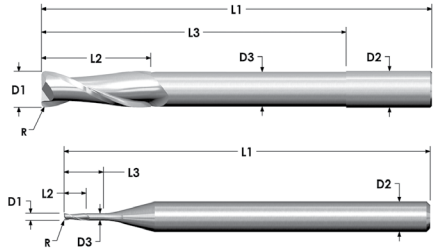

nACRo® – Add “K” to the end of Catalog No.
 Metric sizes also available.

MEF		Cutter Diameter (D1)	Flute Length (L2)	Overall Reach (L3)	Neck Diameter (D3)	Tool Radius (R)	Overall Length (L1)
2 FLUTE Catalog No.	3 FLUTE Catalog No.	inch	inch	inch	inch	inch	inch
1/8" Shanks – D2							
MEF-062-093-015	MEF-062-093-3-015	.0625	.093	.093	.062	.015	1.500
MEF-062-200-005	MEF-062-200-3-005	.0625	.093	.200	.058	.005	1.500
MEF-062-200-010	MEF-062-200-3-010	.0625	.093	.200	.058	.010	1.500
MEF-062-200-015	MEF-062-200-3-015	.0625	.093	.200	.058	.015	1.500
MEF-062-350-005	MEF-062-350-3-005	.0625	.093	.350	.058	.005	1.500
MEF-062-350-010	MEF-062-350-3-010	.0625	.093	.350	.058	.010	1.500
MEF-062-350-015	MEF-062-350-3-015	.0625	.093	.350	.058	.015	1.500
MEF-062-550-005	MEF-062-550-3-005	.0625	.093	.550	.058	.005	1.500
MEF-062-550-010	MEF-062-550-3-010	.0625	.093	.550	.058	.010	1.500
MEF-062-550-015	MEF-062-550-3-015	.0625	.093	.550	.058	.015	1.500
MEF-062-750-005	MEF-062-750-3-005	.0625	.093	.750	.058	.005	2.000
MEF-062-750-010	MEF-062-750-3-010	.0625	.093	.750	.058	.010	2.000
MEF-062-750-015	MEF-062-750-3-015	.0625	.093	.750	.058	.015	2.000
MEF-075-113	MEF-075-113-3	.0750	.113	.113	.075	.000	1.500
MEF-075-250	MEF-075-250-3	.0750	.113	.250	.071	.000	1.500
MEF-075-400	MEF-075-400-3	.0750	.113	.400	.071	.000	1.500
MEF-075-600	MEF-075-600-3	.0750	.113	.600	.071	.000	2.000
MEF-075-900	MEF-075-900-3	.0750	.113	.900	.071	.000	2.000
MEF-075-113-005	MEF-075-113-3-005	.0750	.113	.113	.075	.005	1.500
MEF-075-113-010	MEF-075-113-3-010	.0750	.113	.113	.075	.010	1.500
MEF-075-113-015	MEF-075-113-3-015	.0750	.113	.113	.075	.015	1.500
MEF-075-250-005	MEF-075-250-3-005	.0750	.113	.250	.071	.005	1.500
MEF-075-250-010	MEF-075-250-3-010	.0750	.113	.250	.071	.010	1.500
MEF-075-250-015	MEF-075-250-3-015	.0750	.113	.250	.071	.015	1.500
MEF-075-400-005	MEF-075-400-3-005	.0750	.113	.400	.071	.005	1.500
MEF-075-400-010	MEF-075-400-3-010	.0750	.113	.400	.071	.010	1.500
MEF-075-400-015	MEF-075-400-3-015	.0750	.113	.400	.071	.015	1.500
MEF-075-600-005	MEF-075-600-3-005	.0750	.113	.600	.071	.005	2.000
MEF-075-600-010	MEF-075-600-3-010	.0750	.113	.600	.071	.010	2.000
MEF-075-600-015	MEF-075-600-3-015	.0750	.113	.600	.071	.015	2.000
MEF-075-900-005	MEF-075-900-3-005	.0750	.113	.900	.071	.005	2.000
MEF-075-900-010	MEF-075-900-3-010	.0750	.113	.900	.071	.010	2.000
MEF-075-900-015	MEF-075-900-3-015	.0750	.113	.900	.071	.015	2.000

FEATURING:

- These precision miniature end mills are ideal for finishing and semi-finishing cuts and universal milling applications in soft, medium and hard materials.
- 1.5x to 12x Reach Lengths.
- Machine Hardened Materials 45-68 Rc
- Extra Fine Carbide End Mills Engineered for Hard Milling Applications.

Page 274
for Coating Info

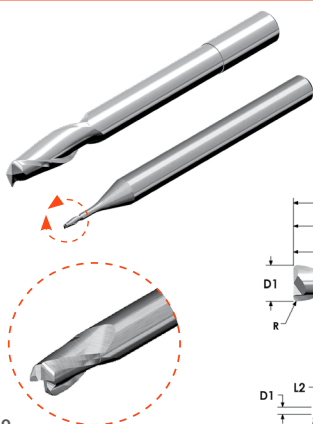

Tolerances:
Shank Diameter: $-.0001"-.0003"$
Cutter Diameter: $0"-.0005"$
T.I.R. MAX: $.0005"$
Longer necks are reduced neck

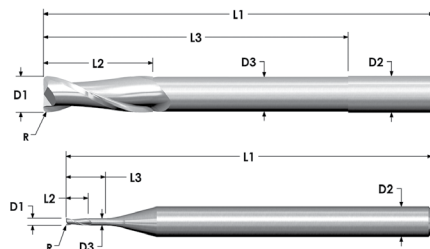

nACRo® – Add “K” to the end of Catalog No.
Metric sizes also available.

MEF		Cutter Diameter (D1)	Flute Length (L2)	Overall Reach (L3)	Neck Diameter (D3)	Tool Radius (R)	Overall Length (L1)
2 FLUTE Catalog No.	3 FLUTE Catalog No.	inch	inch	inch	inch	inch	inch
1/8" Shanks – D2							
MEF-078-117	MEF-078-117-3	.0781	.117	.117	.078	.000	1.500
MEF-078-250	MEF-078-250-3	.0781	.117	.250	.074	.000	1.500
MEF-078-400	MEF-078-400-3	.0781	.117	.400	.074	.000	1.500
MEF-078-650	MEF-078-650-3	.0781	.117	.650	.074	.000	2.000
MEF-078-900	MEF-078-900-3	.0781	.117	.900	.074	.000	2.000
MEF-078-117-005	MEF-078-117-3-005	.0781	.117	.117	.078	.005	1.500
MEF-078-117-010	MEF-078-117-3-010	.0781	.117	.117	.078	.010	1.500
MEF-078-117-015	MEF-078-117-3-015	.0781	.117	.117	.078	.015	1.500
MEF-078-250-005	MEF-078-250-3-005	.0781	.117	.250	.074	.005	1.500
MEF-078-250-010	MEF-078-250-3-010	.0781	.117	.250	.074	.010	1.500
MEF-078-250-015	MEF-078-250-3-015	.0781	.117	.250	.074	.015	1.500
MEF-078-400-005	MEF-078-400-3-005	.0781	.117	.400	.074	.005	1.500
MEF-078-400-010	MEF-078-400-3-010	.0781	.117	.400	.074	.010	1.500
MEF-078-400-015	MEF-078-400-3-015	.0781	.117	.400	.074	.015	1.500
MEF-078-650-005	MEF-078-650-3-005	.0781	.117	.650	.074	.005	2.000
MEF-078-650-010	MEF-078-650-3-010	.0781	.117	.650	.074	.010	2.000
MEF-078-650-015	MEF-078-650-3-015	.0781	.117	.650	.074	.015	2.000
MEF-078-900-005	MEF-078-900-3-005	.0781	.117	.900	.074	.005	2.000
MEF-078-900-010	MEF-078-900-3-010	.0781	.117	.900	.074	.010	2.000
MEF-078-900-015	MEF-078-900-3-015	.0781	.117	.900	.074	.015	2.000
MEF-090-125	–	.0900	.125	.125	.090	.000	1.500
MEF-090-250	–	.0900	.125	.250	.086	.000	1.500
MEF-090-400	–	.0900	.125	.400	.086	.000	1.500
MEF-090-650	–	.0900	.125	.650	.086	.000	2.000
MEF-090-900	–	.0900	.125	.900	.086	.000	2.000
MEF-090-125-005	–	.0900	.125	.125	.090	.005	1.500
MEF-090-125-010	–	.0900	.125	.125	.090	.010	1.500
MEF-090-125-015	–	.0900	.125	.125	.090	.015	1.500
MEF-090-250-005	–	.0900	.125	.250	.086	.005	1.500
MEF-090-250-010	–	.0900	.125	.250	.086	.010	1.500
MEF-090-250-015	–	.0900	.125	.250	.086	.015	1.500
MEF-090-400-005	–	.0900	.125	.400	.086	.005	1.500

MEF

2 Flute, Extra Fine Carbide, Hard Milling, Miniature End Mills



FEATURING:

- These precision miniature end mills are ideal for finishing and semi-finishing cuts and universal milling applications in soft, medium and hard materials.
- 1.5x to 12x Reach Lengths.
- Machine Hardened Materials 45-68 Rc
- Extra Fine Carbide End Mills Engineered for Hard Milling Applications.

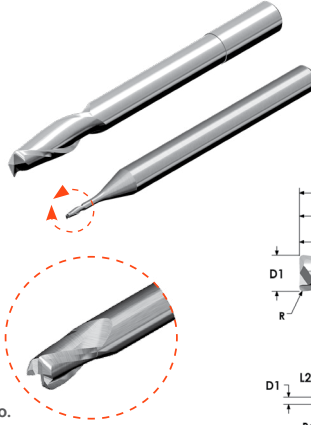

Tolerances:
 Shank Diameter: -.0001"-.0003"
 Cutter Diameter: 0" - .0005"
 T.I.R. MAX: .0005"
Longer necks are reduced neck

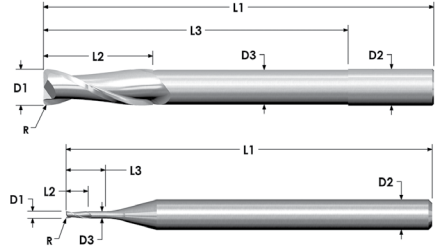

nACRo® – Add “K” to the end of Catalog No.
 Metric sizes also available.

MEF 2 FLUTE Catalog No.	Cutter Diameter (D1)	Flute Length (L2)	Overall Reach (L3)	Neck Diameter (D3)	Tool Radius (R)	Overall Length (L1)
	inch	inch	inch	inch	inch	inch
1/8" Shanks – D2						
MEF-090-400-010	.0900	.125	.400	.086	.010	1.500
MEF-090-400-015	.0900	.125	.400	.086	.015	1.500
MEF-090-650-005	.0900	.125	.650	.086	.005	2.000
MEF-090-650-010	.0900	.125	.650	.086	.010	2.000
MEF-090-650-015	.0900	.125	.650	.086	.015	2.000
MEF-090-900-005	.0900	.125	.900	.086	.005	2.000
MEF-090-900-010	.0900	.125	.900	.086	.010	2.000
MEF-090-900-015	.0900	.125	.900	.086	.015	2.000
MEF-093-125	.0938	.125	.125	.093	.000	1.500
MEF-093-250	.0938	.125	.250	.089	.000	1.500
MEF-093-500	.0938	.125	.500	.089	.000	1.500
MEF-093-750	.0938	.125	.750	.089	.000	2.000
MEF-093-1000	.0938	.125	1.000	.089	.000	2.000
MEF-093-125-005	.0938	.125	.125	.093	.005	1.500
MEF-093-125-010	.0938	.125	.125	.093	.010	1.500
MEF-093-125-015	.0938	.125	.125	.093	.015	1.500
MEF-093-250-005	.0938	.125	.250	.089	.005	1.500
MEF-093-250-010	.0938	.125	.250	.089	.010	1.500
MEF-093-250-015	.0938	.125	.250	.089	.015	1.500
MEF-093-500-005	.0938	.125	.500	.089	.005	1.500
MEF-093-500-010	.0938	.125	.500	.089	.010	1.500
MEF-093-500-015	.0938	.125	.500	.089	.015	1.500
MEF-093-750-005	.0938	.125	.750	.089	.005	2.000
MEF-093-750-010	.0938	.125	.750	.089	.010	2.000
MEF-093-750-015	.0938	.125	.750	.089	.015	2.000
MEF-093-1000-005	.0938	.125	1.000	.089	.005	2.000
MEF-093-1000-010	.0938	.125	1.000	.089	.010	2.000
MEF-093-1000-015	.0938	.125	1.000	.089	.015	2.000

Page 274
for Coating
Info

For current pricing and availability please visit our website at www.micro100.com

FEATURING:

- These precision miniature end mills are ideal for finishing and semi-finishing cuts and universal milling applications in soft, medium and hard materials.
- 1.5x to 12x Reach Lengths.
- Machine Hardened Materials 45-68 Rc
- Extra Fine Carbide End Mills Engineered for Hard Milling Applications.

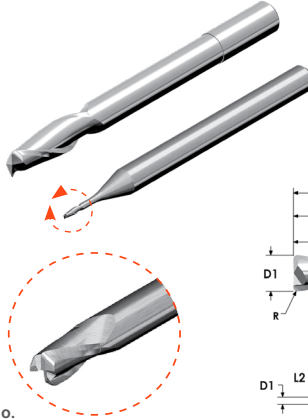

Tolerances:
Shank Diameter: -.0001" - .0003"
Cutter Diameter: 0" - .0005"
T.I.R. MAX: .0005"

Longer necks are reduced neck

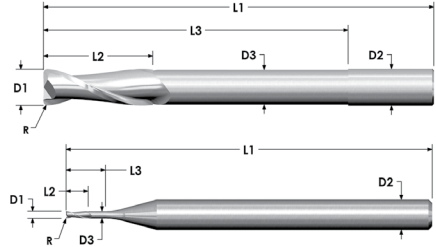

nACRo® – Add "K" to the end of Catalog No.
Metric sizes also available.

MEF	Cutter Diameter (D1)	Flute Length (L2)	Overall Reach (L3)	Neck Diameter (D3)	Tool Radius (R)	Overall Length (L1)
2 FLUTE Catalog No.	inch	inch	inch	inch	inch	inch
3/16" Shanks – D2						
MEF-125-125	.1250	.125	.125	.125	.000	2.000
MEF-125-375	.1250	.125	.375	.121	.000	2.000
MEF-125-750	.1250	.125	.750	.121	.000	2.000
MEF-125-1000	.1250	.125	1.000	.121	.000	2.000
MEF-125-1500	.1250	.125	1.500	.121	.000	3.000
MEF-125-125-005	.1250	.125	.125	.125	.005	2.000
MEF-125-125-010	.1250	.125	.125	.125	.010	2.000
MEF-125-125-015	.1250	.125	.125	.125	.015	2.000
MEF-125-375-005	.1250	.125	.375	.121	.005	2.000
MEF-125-375-010	.1250	.125	.375	.121	.010	2.000
MEF-125-375-015	.1250	.125	.375	.121	.015	2.000
MEF-125-750-005	.1250	.125	.750	.121	.005	2.000
MEF-125-750-010	.1250	.125	.750	.121	.010	2.000
MEF-125-750-015	.1250	.125	.750	.121	.015	2.000
MEF-125-1000-005	.1250	.125	1.000	.121	.005	2.000
MEF-125-1000-010	.1250	.125	1.000	.121	.010	2.000
MEF-125-1000-015	.1250	.125	1.000	.121	.015	2.000
MEF-125-1500-005	.1250	.125	1.500	.121	.005	3.000
MEF-125-1500-010	.1250	.125	1.500	.121	.010	3.000
MEF-125-1500-015	.1250	.125	1.500	.121	.015	3.000

Page 274
for Coating
Info

For current pricing and availability please visit our website at www.micro100.com

FEATURING:

- These high-performance stub length end mills feature a 45° helix and are engineered for **high speed cutting in aluminum, non-ferrous materials and soft materials.**
- The special flute geometry and short flute length provide an extremely smooth and silent cutting action for an exceptional surface finish.

Page 274
for Coating
Info

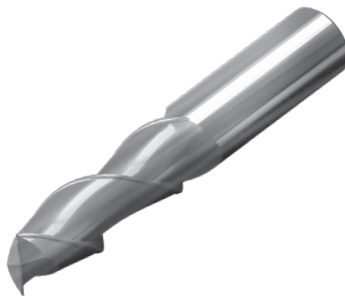

Tolerances:
Shank Diameter:
-.0001"-.0003"
Cutter Diameter:
1/16"-1/4": .000"-.002"
9/32"-1": .000"-.003"
T.I.R. MAX: .0005"

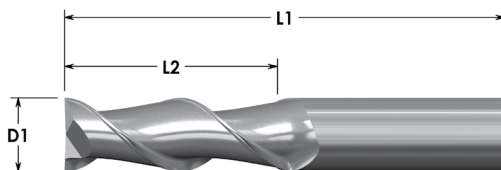

Developed Specifically for
Aluminum / Non-Ferrous Materials

ZrN Add "S" to end of Catalog No.

Metric sizes also available.

ASM	Cutter Diameter (D1)	Flute Length (L2)	Overall Length (L1)
2 FLUTE Catalog No.	fraction	fraction	inch
1/8" Shanks – D2			
ASM-062-2	1/16	1/8	1.500
ASM-093-2	3/32	3/16	1.500
ASM-125-2	1/8	1/4	1.500
3/16" Shanks – D2			
ASM-156-2	5/32	5/16	1.500
ASM-187-2	3/16	3/8	1.500
1/4" Shanks – D2			
ASM-250-2	1/4	1/2	2.000
5/16" Shanks – D2			
ASM-312-2	5/16	1/2	2.000
3/8" Shanks – D2			
ASM-375-2	3/8	5/8	2.000
7/16" Shanks – D2			
ASM-437-2 ♦	7/16	5/8	2.500
1/2" Shanks – D2			
ASM-500-2	1/2	5/8	2.500

♦ WHILE SUPPLIES LAST - Discontinued

For current pricing and availability please visit our website at www.micro100.com

FEATURING:

- These high-performance stub length end mills feature a 45° helix and are engineered for high speed cutting in aluminum, non-ferrous materials and soft materials.
- The special flute geometry and short flute length provide an extremely smooth and silent cutting action for an exceptional surface finish.



Tolerances:
 Shank Diameter:
 -.0001"-.0003"
 Cutter Diameter:
 1/16"-1/4": .000"-.002"
 9/32"-1": .000"-.003"
 T.I.R. MAX: .0005"

Page 274
for Coating
Info

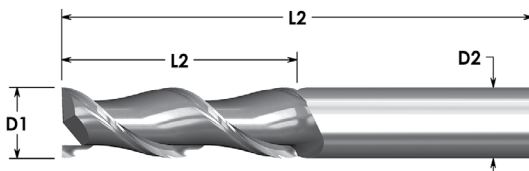

Developed Specifically for
Aluminum / Non-Ferrous Materials

ZrN Add "S" to end of Catalog No.

Metric sizes also available.

ARM	ARM	Cutter Diameter (D1)	Flute Length (L2)	Overall Length (L1)
2 FLUTE Catalog No.	3 FLUTE Catalog No.			
1/8" Shanks – D2				
ARM-062-2	–	1/16	3/16	1.500
ARM-093-2	–	3/32	3/8	1.500
ARM-125-2	–	1/8	1/2	1.500
3/16" Shanks – D2				
ARM-156-2	–	5/32	9/16	2.000
ARM-187-2	–	3/16	5/8	2.000
1/4" Shanks – D2				
ARM-250-2	ARM-250-3	1/4	3/4	2.500
5/16" Shanks – D2				
ARM-281-2	ARM-281-3	9/32	3/4	2.500
ARM-312-2	ARM-312-3	5/16	13/16	2.500
3/8" Shanks – D2				
ARM-375-2	ARM-375-3	3/8	7/8	2.500
1/2" Shanks – D2				
ARM-500-2	ARM-500-3	1/2	1	3.000
ARM-5125-2 ★	ARM-5125-3 ★	1/2	1-1/4	3.500
5/8" Shanks – D2				
–	ARM-625-3	5/8	1-1/4	3.500
3/4" Shanks – D2				
ARM-687-2 ♦	–	11/16	1-3/8	4.000
ARM-750-2 ♦	ARM-750-3 ♦	3/4	1-1/2	4.000
1" Shanks – D2				
–	ARM-001-3 ♦	1	1-1/2	4.000

♦ WHILE SUPPLIES LAST - Discontinued

ARC

2 & 3 Flute Center Cutting,
45° Helix, End Mills with
Corner Radius

MICRO 100®
super carbide tools

FEATURING:

- These high-performance stub length end mills feature a 45° helix and are engineered for **high speed cutting in aluminum, non-ferrous materials and soft materials.**
- The special flute geometry and short flute length provide an extremely smooth and silent cutting action for an exceptional surface finish.

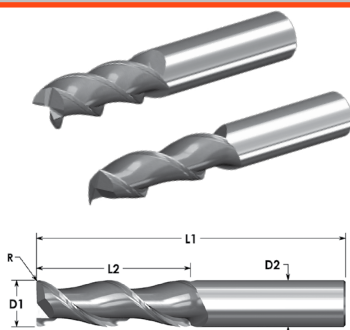

Tolerances:
Shank Diameter: -.0001"--.0003"
Cutter Diameter:
1/16"-1/4": .000"-.002"
9/32"-1": .000"-.003"
T.I.R. MAX: .0005"

Developed Specifically for
Aluminum / Non-Ferrous Materials

ZrN Add "S" to end of Catalog No.

Metric sizes also available.

ARC		ARC		Cutter Diameter (D1)	Flute Length (L2)	Corner Radius (R)	Overall Length (L1)
2 FLUTE Catalog No.		3 FLUTE Catalog No.		fraction	fraction	inch	inch
1/8" Shanks – D2							
ARC-062-2-005 ♦		–		1/16	3/16	.005	1.500
ARC-093-2-005		–		3/32	3/8	.005	1.500
ARC-093-2-010		–		3/32	3/8	.010	1.500
ARC-125-2-010		–		1/8	1/2	.010	1.500
1/4" Shanks – D2							
ARC-250-2-010		–		1/4	3/4	.010	2.500
–	ARC-250-3-030			1/4	3/4	.030	2.500
5/16" Shanks – D2							
ARC-312-2-020 ♦		–		5/16	13/16	.020	2.500
ARC-312-2-030 ♦	ARC-312-3-030			5/16	13/16	.030	2.500
3/8" Shanks – D2							
ARC-375-2-010 ♦		–		3/8	7/8	.010	2.500
ARC-375-2-060 ♦		–		3/8	7/8	.060	2.500
1/2" Shanks – D2							
ARC-500-2-010 ♦		–		1/2	1	.010	3.000
ARC-500-2-020 ♦		–		1/2	1	.020	3.000
ARC-500-2-030 ♦	ARC-500-3-030			1/2	1	.030	3.000
ARC-500-2-060 ♦	ARC-500-3-060			1/2	1	.060	3.000
–	ARC-5125-3-030 ★			1/2	1-1/4	.030	3.500
5/8" Shanks – D2							
ARC-625-2-020 ♦	ARC-625-3-020 ♦			5/8	1-1/4	.020	3.500
ARC-625-2-030 ♦	–			5/8	1-1/4	.030	3.500
ARC-625-2-060 ♦	ARC-625-3-060 ♦			5/8	1-1/4	.060	3.500
ARC-625-2-090 ♦	ARC-625-3-090 ♦			5/8	1-1/4	.090	3.500
3/4" Shanks – D2							
ARC-750-2-020 ♦	–			3/4	1-1/2	.020	4.000
–	ARC-750-3-030 ♦			3/4	1-1/2	.030	4.000
ARC-750-2-060 ♦	–			3/4	1-1/2	.060	4.000
ARC-750-2-090 ♦	ARC-750-3-090 ♦			3/4	1-1/2	.090	4.000
ARC-750-2-125 ♦	–			3/4	1-1/2	.125	4.000
1" Shanks – D2							
ARC-001-2-020 ♦	ARC-001-3-020 ♦			1	1-1/2	.020	4.000
ARC-001-2-030 ♦	ARC-001-3-030 ♦			1	1-1/2	.030	4.000
ARC-001-2-060 ♦	ARC-001-3-060 ♦			1	1-1/2	.060	4.000
ARC-001-2-090 ♦	ARC-001-3-090 ♦			1	1-1/2	.090	4.000
ARC-001-2-125 ♦	ARC-001-3-125 ♦			1	1-1/2	.125	4.000

♦ WHILE SUPPLIES LAST - Discontinued

FEATURING:

- The conventional tool geometry supports applications in a wide scope of different material, ranging from soft to hard.

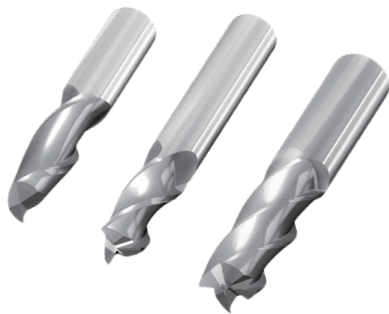

Tolerances:
Cutter Diameter:
1/32"-1/4": +0"/-.002"
9/32"-1": +0"/-.003"
T.I.R. MAX: .0005"

Page 274
for Coating
Info

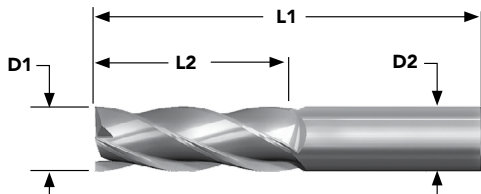

AITiN – Add “X” to the end of Catalog No.
Metric sizes also available.

GEM			Cutter Diameter (D1)	Flute Length (L2)	Overall Length (L1)
2 FLUTE Catalog No.	3 FLUTE Catalog No.	4 FLUTE Catalog No.	inch	inch	inch
1/8" Shanks – D2					
GEM-031-2	GEM-031-3	GEM-031-4	1/32	5/64	1.500
GEM-046-2	GEM-046-3	GEM-046-4	3/64	7/64	1.500
GEM-062-2	GEM-062-3	GEM-062-4	1/16	3/16	1.500
GEM-078-2	GEM-078-3	GEM-078-4	5/64	3/16	1.500
GEM-093-2	GEM-093-3	GEM-093-4	3/32	3/8	1.500
GEM-109-2	GEM-109-3	GEM-109-4	7/64	3/8	1.500
GEM-125-2	GEM-125-3	GEM-125-4	1/8	1/2	1.500
3/16" Shanks – D2					
GEM-140-2	GEM-140-3	GEM-140-4	9/64	1/2	2.000
GEM-156-2	GEM-156-3	GEM-156-4	5/32	9/16	2.000
GEM-171-2	–	GEM-171-4	11/64	5/8	2.000
GEM-187-2	GEM-187-3	GEM-187-4	3/16	5/8	2.000
1/4" Shanks – D2					
GEM-203-2 ♦	–	GEM-203-4	13/64	5/8	2.500
GEM-218-2	–	GEM-218-4	7/32	5/8	2.500
GEM-250-2	GEM-250-3	GEM-250-4	1/4	3/4	2.500
5/16" Shanks – D2					
GEM-281-2	GEM-281-3	GEM-281-4	9/32	3/4	2.500
GEM-312-2	–	GEM-312-4	5/16	13/16	2.500
3/8" Shanks – D2					
GEM-375-2	GEM-375-3	GEM-375-4	3/8	7/8	2.500
7/16" Shanks – D2					
–	–	GEM-437-4	7/16	1	2.500
1/2" Shanks – D2					
GEM-500-2	GEM-500-3	GEM-500-4	1/2	1	3.000
–	–	GEM-5125-4 *	1/2	1-1/4	3.500

♦ WHILE SUPPLIES LAST - Discontinued

For current pricing and availability please visit our website at www.micro100.com

GEM
2/3/4 Flute Center Cutting,
30° Helix, General
Application End Mills

MICRO 100®
super carbide tools

FEATURING:

- The conventional tool geometry supports applications in a wide scope of different material, ranging from soft to hard.

Page 274
for Coating
Info

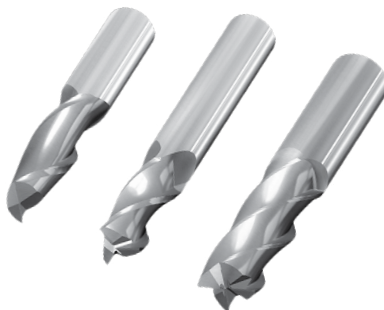

Tolerances:
Cutter Diameter:
1/32"-1/4": +0"/-0.002"
9/32"-1": +0"/-0.003"
T.I.R. MAX: .0005"

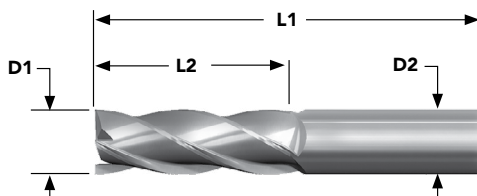

AITiN – Add "X" to the end of Catalog No.

Metric sizes also available.

GEM			Cutter Diameter (D1)	Flute Length (L2)	Overall Length (L1)
2 FLUTE Catalog No.	3 FLUTE Catalog No.	4 FLUTE Catalog No.	inch	inch	inch
9/16" Shanks - D2					
GEM-562-2	-	GEM-562-4	9/16	1-1/4	3.500
5/8" Shanks - D2					
-	-	GEM-625-4	5/8	1-1/4	3.500
3/4" Shanks - D2					
GEM-687-2 ♦	-	-	3/4	1-1/2	4.000
GEM-750-2	-	GEM-750-4	3/4	1-1/2	4.000
7/8" Shanks - D2					
GEM-875-2 ♦	GEM-875-3 ♦	GEM-875-4	7/8	1-1/2	4.000
1" Shanks - D2					
GEM-001-2 ♦	-	GEM-001-4	1	1-1/2	4.000

♦ WHILE SUPPLIES LAST - Discontinued

D

FEATURING:

- Engineered with various corner radii per cutting diameter, GEC end mills are suited for heavier cuts in medium and hard materials.

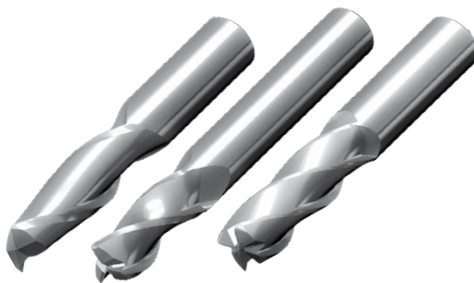

Tolerances:
Cutter Diameter:
1/32"-1/4": +0"/-.002"
9/32"-1": +0"/-.003"
T.I.R. MAX: .0005"

Page 274
for Coating
Info

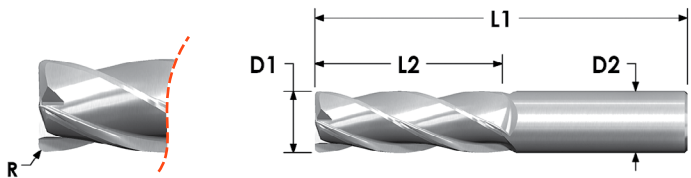

AITiN – Add "X" to the end of Catalog No.

Metric sizes also available.

GEC			Cutter Diameter (D1)	Flute Length (L2)	Corner Radius (R)	Overall Length (L1)
2 FLUTE Catalog No.	3 FLUTE Catalog No.	4 FLUTE Catalog No.				
1/8" Shanks – D2						
GEC-031-2-005 ♦	GEC-031-3-005	GEC-031-4-005	1/32	5/64	.005	1.500
GEC-062-2-005	GEC-062-3-005	GEC-062-4-005	1/16	3/16	.005	1.500
GEC-062-2-010	GEC-062-3-010	GEC-062-4-010	1/16	3/16	.010	1.500
GEC-093-2-005 ♦	GEC-093-3-005 ♦	GEC-093-4-005	3/32	3/8	.005	1.500
GEC-093-2-010	GEC-093-3-010	GEC-093-4-010	3/32	3/8	.010	1.500
–	GEC-125-3-005	–	1/8	1/2	.005	1.500
–	GEC-125-3-010	GEC-125-4-010	1/8	1/2	.010	1.500
GEC-125-2-020	GEC-125-3-020 ♦	GEC-125-4-020	1/8	1/2	.020	1.500
3/16" Shanks – D2						
GEC-187-2-010	GEC-187-3-010 ♦	GEC-187-4-010	3/16	5/8	.010	2.000
GEC-187-2-020 ♦	GEC-187-3-020	GEC-187-4-020	3/16	5/8	.020	2.000
GEC-187-2-030 ♦	GEC-187-3-030	GEC-187-4-030	3/16	5/8	.030	2.000
1/4" Shanks – D2						
GEC-250-2-010	–	GEC-250-4-010	1/4	3/4	.010	2.000
GEC-250-2-020	GEC-250-3-020	GEC-250-4-020	1/4	3/4	.020	2.000
GEC-250-2-030 ♦	GEC-250-3-030	GEC-250-4-030	1/4	3/4	.030	2.000
5/16" Shanks – D2						
GEC-312-2-010	–	GEC-312-4-010	5/16	13/16	.010	2.500
GEC-312-2-020 ♦	–	–	5/16	13/16	.020	2.500
–	GEC-312-3-030 ♦	–	5/16	13/16	.030	2.500
3/8" Shanks – D2						
GEC-375-2-010	–	GEC-375-4-010	3/8	7/8	.010	2.500
–	–	GEC-375-4-020	3/8	7/8	.020	2.500
GEC-375-2-030 ♦	GEC-375-3-030	GEC-375-4-030	3/8	7/8	.030	2.500
–	GEC-375-3-060	–	3/8	7/8	.060	2.500

♦ WHILE SUPPLIES LAST - Discontinued

GEC

2/3/4 Flute Center Cutting,
30° Helix, End Mills
with Corner Radius

MICRO 100®

super carbide tools

FEATURING:

- Engineered with various corner radii per cutting diameter, GEC end mills are suited for heavier cuts in medium and hard materials.

Page 274
for Coating
Info

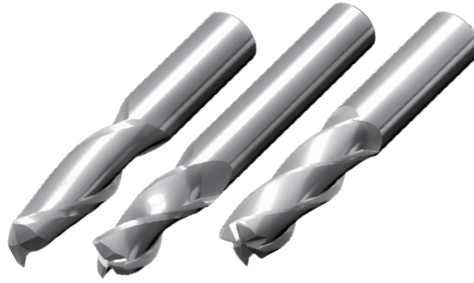

Tolerances:
Cutter Diameter:
1/32"-1/4": +0"/-.002"
9/32"-1": +0"/-.003"
T.I.R. MAX: .0005"

D

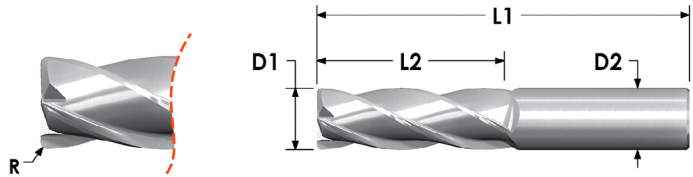

AITiN – Add “X” to the end of Catalog No.

Metric sizes also available.

GEC			Cutter Diameter (D1)	Flute Length (L2)	Corner Radius (R)	Overall Length (L1)
2 FLUTE Catalog No.	3 FLUTE Catalog No.	4 FLUTE Catalog No.	inch	inch	inch	inch
1/2 " Shanks – D2						
-	-	GEC-500-4-010	1/2	1	.010	3.000
GEC-500-2-020 ♦	-	-	1/2	1	.020	3.000
-	GEC-500-3-030	-	1/2	1	.030	3.000
5/8 " Shanks – D2						
GEC-625-2-020 ♦	GEC-625-3-020 ♦	-	5/8	1-1/4	.020	3.500
GEC-625-2-030 ♦	GEC-625-3-030 ♦	GEC-625-3-030 ♦	5/8	1-1/4	.030	3.500
GEC-625-2-060 ♦	GEC-625-3-060 ♦	-	5/8	1-1/4	.060	3.500
GEC-625-2-090 ♦	GEC-625-3-090 ♦	GEC-625-3-090 ♦	5/8	1-1/4	.090	3.500
3/4 " Shanks – D2						
GEC-750-2-020 ♦	GEC-750-3-020 ♦	-	3/4	1-1/2	.020	4.000
GEC-750-2-030 ♦	-	-	3/4	1-1/2	.030	4.000
GEC-750-2-060 ♦	-	-	3/4	1-1/2	.060	4.000
GEC-750-2-125 ♦	-	GEC-750-4-125 ♦	3/4	1-1/2	.125	4.000
1 " Shanks – D2						
GEC-001-2-020 ♦	-	GEC-001-4-020 ♦	1	1-1/2	.020	4.000
GEC-001-2-030 ♦	GEC-001-3-030 ♦	GEC-001-4-030 ♦	1	1-1/2	.030	4.000
GEC-001-2-060 ♦	GEC-001-3-060 ♦	-	1	1-1/2	.060	4.000
GEC-001-2-090 ♦	GEC-001-3-090 ♦	-	1	1-1/2	.090	4.000
GEC-001-2-125 ♦	GEC-001-3-125 ♦	-	1	1-1/2	.125	4.000

♦ WHILE SUPPLIES LAST - Discontinued

FEATURING:

- These end mills feature a .001" plus tolerance on the cutting diameter.



Tolerances:
Cutter Diameter: $+.001"/-0"$

Page 274
for Coating
Info

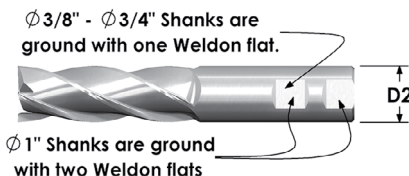
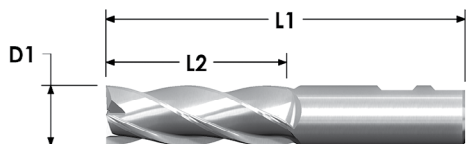

D

EMS				Cutter Diameter (D1)	Flute Length (L2)	Overall Length (L1)
2 FLUTE Catalog No.	3 FLUTE Catalog No.	4 FLUTE Catalog No.	6 FLUTE Catalog No.			
				inch	inch	inch
1/8" Shanks – D2						
EMS-031-2	EMS-031-3	EMS-031-4	–	1/32	5/64	1.500
EMS-062-2	EMS-062-3	EMS-062-4	–	1/16	3/16	1.500
EMS-093-2	EMS-093-3	EMS-093-4	–	3/32	3/8	1.500
EMS-125-2	EMS-125-3	EMS-125-4	–	1/8	1/2	1.500
3/16" Shanks – D2						
EMS-156-2 ♦	EMS-156-3 ♦	EMS-156-4	–	5/32	9/16	2.000
EMS-187-2	EMS-187-3	EMS-187-4	–	3/16	5/8	2.000
1/4" Shanks – D2						
–	EMS-218-3	–	–	7/32	5/8	2.500
EMS-250-2	EMS-250-3	EMS-250-4	–	1/4	3/4	2.500
5/16" Shanks – D2						
EMS-281-2 ♦	–	–	–	9/32	3/4	2.500
EMS-312-2	–	EMS-312-4	–	5/16	13/16	2.500
3/8" Shanks – D2						
EMS-375-2	EMS-375-3	EMS-375-4	–	3/8	7/8	2.500
7/16" Shanks – D2						
EMS-437-2 ♦	EMS-437-3 ♦	–	–	7/16	1	2.500
1/2" Shanks – D2						
EMS-500-2	EMS-500-3	EMS-500-4	–	1/2	1	3.000
9/16" Shanks – D2						
EMS-562-2 ♦	EMS-562-3 ♦	EMS-562-4 ♦	–	9/16	1-1/4	3.500
5/8" Shanks – D2						
EMS-625-2 ♦	EMS-625-3	EMS-625-4	–	5/8	1-1/4	3.500
11/16" Shanks – D2						
–	EMS-687-3 ♦	–	–	11/16	1-3/8	4.000
3/4" Shanks – D2						
EMS-750-2	–	EMS-750-4	–	3/4	1-1/2	4.000
1" Shanks – D2						
EMS-001-2 ♦	EMS-001-3	–	EMS-001-6 * NEW	1	2-1/2	5.000

♦ WHILE SUPPLIES LAST - Discontinued

SEM

2/3 Flute Center Cutting,
30° Helix, Stub Length End Mills



FEATURING:

- These universal application type end mills feature a stub length and are engineered for milling applications in a wide scope of different materials, ranging from soft to hard.



Tolerances:
Cutter Diameter:
1/32"-1/4": 0"- .002"
17/64"-1/2": 0"- .003"
T.I.R. MAX: .0005"

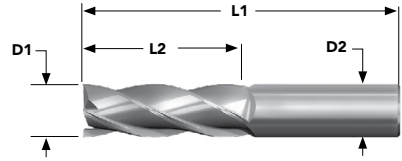

AITiN – Add “X” to the end of Catalog No.
Metric sizes also available.

SEM			Cutter Diameter (D1)	Flute Length (L2)	Overall Length (L1)
2 FLUTE Catalog No.	3 FLUTE Catalog No.	4 FLUTE Catalog No.	inch	inch	inch
1/8" Shanks – D2					
SEM-031-02	SEM-031-03	SEM-031-04	1/32	1/16	1.500
SEM-046-02	SEM-046-03	SEM-046-04	3/64	3/32	1.500
SEM-062-02	SEM-062-03	SEM-062-04	1/16	1/8	1.500
SEM-078-02	SEM-078-03	SEM-078-04	5/64	5/32	1.500
SEM-093-02	SEM-093-03	SEM-093-04	3/32	3/16	1.500
SEM-109-02	SEM-109-03	SEM-109-04	7/64	3/16	1.500
SEM-125-02	SEM-125-03	SEM-125-04	1/8	1/4	1.500
3/16" Shanks – D2					
SEM-140-02	SEM-140-03	SEM-140-04	9/64	1/4	1.500
SEM-156-02	SEM-156-03	SEM-156-04	5/32	5/16	1.500
SEM-171-02 ♦	SEM-171-03	SEM-171-04	11/64	5/16	1.500
SEM-187-02	SEM-187-03	SEM-187-04	3/16	3/8	1.500
1/4" Shanks – D2					
–	SEM-203-03	SEM-203-04	13/64	3/8	2.000
–	–	SEM-218-04	7/32	7/16	2.000
SEM-234-02 ♦	–	SEM-234-04	15/64	7/16	2.000
SEM-250-02	SEM-250-03	SEM-250-04	1/4	1/2	2.000
5/16" Shanks – D2					
–	–	SEM-265-04	17/64	1/2	2.000
SEM-281-02 ♦	–	SEM-281-04	9/32	1/2	2.000
SEM-312-02	–	SEM-312-04	5/16	1/2	2.000
3/8" Shanks – D2					
SEM-328-02	SEM-328-03 ♦	SEM-328-04	21/64	1/2	2.000
SEM-359-02 ♦	–	–	23/64	1/2	2.000
SEM-375-02	SEM-375-03	SEM-375-04	3/8	5/8	2.000
7/16" Shanks – D2					
–	–	SEM-390-04	25/64	5/8	2.500
SEM-406-02 ♦	–	–	13/32	5/8	2.500
SEM-421-02 ♦	–	–	27/64	5/8	2.500
SEM-437-02	–	SEM-437-04	7/16	5/8	2.500
1/2" Shanks – D2					
SEM-453-02 ♦	SEM-453-03 ♦	SEM-453-04 ♦	29/64	5/8	2.500
–	SEM-468-03 ♦	–	15/32	5/8	2.500
–	SEM-484-03 ♦	SEM-484-04 ♦	31/64	5/8	2.500
SEM-500-02	SEM-500-03	SEM-500-04	1/2	5/8	2.500

For current pricing and availability please visit our website at www.micro100.com

FEATURING:

- These 60° high helix end mills generate the **highest metal removal rate** in most applications.
- The 3 flute geometry is ideal for roughing and slotting in **all mild steels and stainless steels**.



Tolerances:
Cutter Diameter:
1/4": 0"±.002"
9/32"-1": 0"±.003"
T.I.R. MAX: .0005"

**Page 274
for Coating
Info**

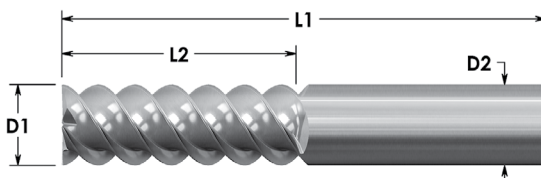

AITiN – Add "X" to the end of Catalog No.
Metric sizes also available.

SDH		Cutter Diameter (D1)	Flute Length (L2)	Overall Length (L1)
3 FLUTE Catalog No.	4 FLUTE Catalog No.			
		inch	inch	inch
1/4" Shanks – D2				
SDH-250-03	–	1/4	3/4	2.500
5/16" Shanks – D2				
SDH-281-03 ♦	–	9/32	3/4	2.500
3/8" Shanks – D2				
–	SDH-375-04	3/8	7/8	2.500
7/16" Shanks – D2				
SDH-437-03 ♦	SDH-437-04 ♦	7/16	1	2.500
1/2" Shanks – D2				
SDH-500-03	SDH-500-04	1/2	1	3.000
5/8" Shanks – D2				
SDH-625-03	SDH-625-04	5/8	1-1/4	3.500
1" Shanks – D2				
SDH-001-03 ♦	SDH-001-04 ♦	1	2-1/2	5.000

♦ WHILE SUPPLIES LAST - Discontinued

For current pricing and availability please visit our website at www.micro100.com

FEATURING:

- These 5 flute, high tech, end mills feature a 45° helix for finishing, roughing, and slotting in medium to hard steels, stainless steels and high temperature alloys.
- The high helix angle aids in reducing chattering, allows for increased metal removal rates, and provides the highest surface finish quality.

Page 274
for Coating
Info



Tolerances:
Cutter Diameter:
3/16"-1/4": 0"±.002"
5/16"-1": 0"±.003"
T.I.R. MAX: .0005"

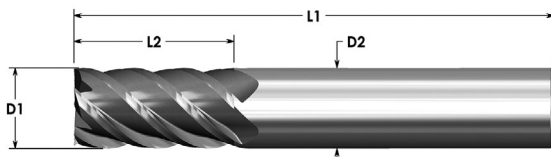

AITiN – Add “X” to the end of Catalog No.

Metric sizes also available.

ASM 5 FLUTE Catalog No.	Cutter Diameter (D1) inch	Flute Length (L2) inch	Overall Length (L1) inch
3/16" Shanks – D2			
ASM-187-5	3/16	3/8	1.500
1/4" Shanks – D2			
ASM-250-5	1/4	1/2	2.000
5/16" Shanks – D2			
ASM-312-5	5/16	1/2	2.000
3/8" Shanks – D2			
ASM-375-5	3/8	5/8	2.000
1/2" Shanks – D2			
ASM-500-5	1/2	5/8	2.000

ARM 5 FLUTE Catalog No.	Cutter Diameter (D1) inch	Flute Length (L2) inch	Overall Length (L1) inch
3/16" Shanks – D2			
ARM-187-5	3/16	5/8	2.000
1/4" Shanks – D2			
ARM-250-5	1/4	3/4	2.500
5/16" Shanks – D2			
ARM-312-5 ♦	5/16	13/16	2.500
3/8" Shanks – D2			
ARM-375-5	3/8	7/8	2.500
1/2" Shanks – D2			
ARM-500-5	1/2	1	3.000

♦ WHILE SUPPLIES LAST - Discontinued

FEATURING:

- These 5 flute high tech end mills feature a 45° helix for roughing, finishing, and slotting in medium to hard steels, stainless steels, and high temperature alloys.
- High metal removal rates as well as excellent finishes are achieved with these 5 flute end mills
- 45° helix diminishes chatter in corner milling applications.
- Engineered with various corner radii per cutting diameter, These end mills are ideally suited for heavier cuts in medium and hard materials.

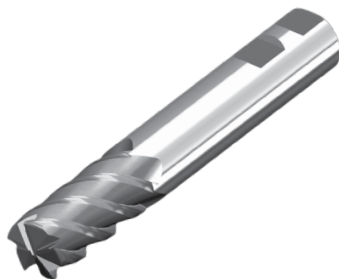

Tolerances:
 Shank Diameter: -.0001"-.0003"
 Cutter Diameter:
 3/16"-1/4": 0"-.002"
 5/16"-1": 0"-.003"
 Corner Radius: ±.0005"
 T.I.R. MAX: .0005"

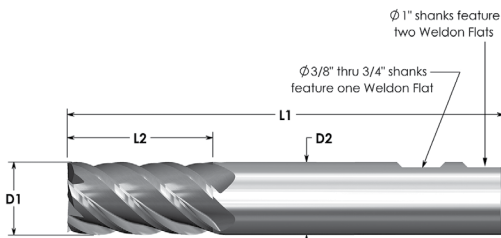

AITiN – Add “X” to the end of Catalog No.
 Metric sizes also available.

ARC 5 FLUTE Catalog No.	Cutter Diameter (D1)	Flute Length (L2)	Corner Radius (R)	Overall Length (L1)
	fraction	fraction	inch	inch
3/16" Shanks – D2				
tt-187-5-010	3/16	5/8	.010	2.000
ARC-187-5-020	3/16	5/8	.020	2.000
ARC-187-5-030	3/16	5/8	.030	2.000
1/4" Shanks – D2				
ARC-250-5-010	1/4	3/4	.010	2.500
ARC-250-5-020	1/4	3/4	.020	2.500
ARC-250-5-030	1/4	3/4	.030	2.500
5/16" Shanks – D2				
ARC-312-5-010	5/16	13/16	.010	2.500
ARC-312-5-020	5/16	13/16	.020	2.500
ARC-312-5-030 ♦	5/16	13/16	.030	2.500
3/8" Shanks – D2				
ARC-375-5-010	3/8	7/8	.010	2.500
ARC-375-5-020	3/8	7/8	.020	2.500
ARC-375-5-030	3/8	7/8	.030	2.500
ARC-375-5-060	3/8	7/8	.060	2.500
1/2" Shanks – D2				
ARC-500-5-010	1/2	1	.010	3.000
ARC-500-5-060	1/2	1	.060	3.000

♦ WHILE SUPPLIES LAST - Discontinued



For current pricing and availability please visit our website at www.micro100.com

ARC

5 Flute, Center Cutting, 45° Helix, End Mills with Corner Radius



FEATURING:

- These 5 flute high tech end mills feature a 45° helix for roughing, finishing, and slotting in medium to hard steels, stainless steels, and high temperature alloys.
- High metal removal rates as well as excellent finishes are achieved with these 5 flute end mills
- 45° helix diminishes chatter in corner milling applications.
- Engineered with various corner radii per cutting diameter, These end mills are ideally suited for heavier cuts in medium and hard materials.



Tolerances:
 Shank Diameter: $\pm .0001'' - .0003''$
 Cutter Diameter:
 3/16"-1/4": $0'' - .002''$
 5/16"-1": $0'' - .003''$
 Corner Radius: $\pm .0005''$
 T.I.R. MAX: $.0005''$

Weldon Flat ground on 3/8" and larger shanks

Ø1" Shanks feature two Weldon Flats

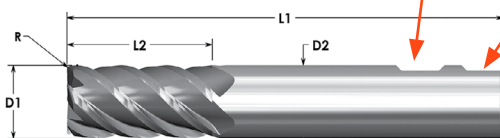

AITIN – Add "X" to the end of Catalog No.

ARC	Cutter Diameter (D1)	Flute Length (L2)	Corner Radius (R)	Overall Length (L1)
5 FLUTE Catalog No.	fraction	fraction	inch	inch
5/8" Shanks – D2				
ARC-625-5-030 ♦	5/8	1-1/4	.030	3.500
ARC-625-5-090 ♦	5/8	1-1/4	.090	3.500
3/4" Shanks – D2				
ARC-750-5-020	3/4	1-1/2	.020	4.000
ARC-750-5-030 ♦	3/4	1-1/2	.030	4.000
ARC-750-5-060 ♦	3/4	1-1/2	.060	4.000
ARC-750-5-090 ♦	3/4	1-1/2	.090	4.000
1" Shanks – D2				
ARC-001-5-020 ♦	1	1-1/2	.020	4.000
ARC-001-5-030 ♦	1	1-1/2	.030	4.000
ARC-001-5-060 ♦	1	1-1/2	.060	4.000
ARC-001-5-090 ♦	1	1-1/2	.090	4.000



For current pricing and availability please visit our website at www.micro100.com

FEATURING:

- These 38° helix end mills provide a superior work piece finish in all milling applications.
- These end mills are very suitable for milling steels, stainless steels, and heat treated materials.
- 6 flute geometry provides excellent shearing action, resulting in the highest dimensional accuracy and reduced work piece distortion, especially in thin wall slotting applications.

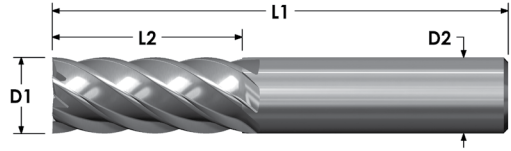

Tolerances:
 Shank Diameter: -.0001"-.0003"
 Cutter Diameter:
 1/4": 0"-.002"
 9/32"-1": 0"-.003"
 T.I.R. MAX: .0005"

AITiN – Add “X” to the end of Catalog No.
 Metric sizes also available.

EMH	Cutter Diameter (D1)	Flute Length (L2)	Overall Length (L1)
6 FLUTE Catalog No.	fraction	fraction	inch
1/4" Shanks – D2			
EMH-250-06	1/4	3/4	2.500
9/32" Shanks – D2			
EMH-281-06	9/32	3/4	2.500
5/16" Shanks – D2			
EMH-312-06	5/16	13/16	2.500
3/8" Shanks – D2			
EMH-375-06	3/8	7/8	2.500
1/2" Shanks – D2			
EMH-500-06	1/2	1	3.000
5/8" Shanks – D2			
EMH-625-06	5/8	1-1/4	3.500
3/4" Shanks – D2			
EMH-750-06	3/4	1-1/4	4.000
1" Shanks – D2			
EMH-000-06 ♦	1	1-1/2	4.000
EMH-001-06	1	2-1/2	5.000

♦ WHILE SUPPLIES LAST - Discontinued



For current pricing and availability please visit our website at www.micro100.com

SHR/SHL

4 Flute, 38° Helix, Regular / Long Length, Roughing End Mills



FEATURING:

- Designed and engineered to generate **maximum** metal removal rates in most applications.

Page 274 for Coating Info

THE SHREDDER

Tolerances:
 Shank Diameter: $-.0001"-.0003"$
 Cutter Diameter: $+.000"-.003"$
 T.I.R. MAX: $.0005"$

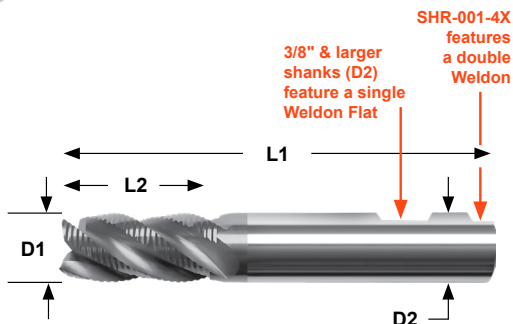

End Mills Coated with:

AlTiN

Metric sizes also available.

SHR 4 FLUTE Catalog No.	Cutter Diameter (D1)	Flute Length (L2)	Overall Length (L1)	SHL 4 FLUTE Catalog No.	Cutter Diameter (D1)	Flute Length (L2)	Overall Length (L1)
	fraction	fraction	inch		fraction	fraction	inch
1/4" Shanks – D2							
SHR-250-4X	1/4	3/4	2.500	SHL-250-4X	1/4	1-1/8	3.000
5/16" Shanks – D2							
SHR-312-4X	5/16	13/16	2.500	SHL-312-4X	5/16	1-1/8	3.000
3/8" Shanks – D2							
SHR-375-4X	3/8	7/8	2.500	SHL-375-4X	3/8	1-1/4	3.000
1/2" Shanks – D2							
SHR-500-4X	1/2	1	3.000	SHL-500-4X	1/2	2	4.500
5/8" Shanks – D2							
SHR-625-4X	5/8	1-1/4	3.500	SHL-625-4X	5/8	2-1/4	5.000
3/4" Shanks – D2							
SHR-750-4X	3/4	1-1/2	4.000	SHL-750-4X	3/4	2-1/2	5.000
1" Shanks – D2							
SHR-001-4X	1	1-1/2	4.000	SHL-001-4X	1	2-1/2	5.000

For current pricing and availability please visit our website at www.micro100.com

Tolerances:
Shank Diameter: -.0001"-.0003"
Cutter Diameter:
1/4": +.000"-.002"
5/16"-1": +.000"-.003"
T.I.R. MAX: .0005"

Page 274
for Coating
Info

THE
V-HEMOTH
HIGH VELOCITY VARIABLE HELIX

FEATURING:

- Variable Pitch
- High-Production / High Speed Milling
- Excellent Surface Finish
- Eliminates Chatter
- Reduces Machine Vibration

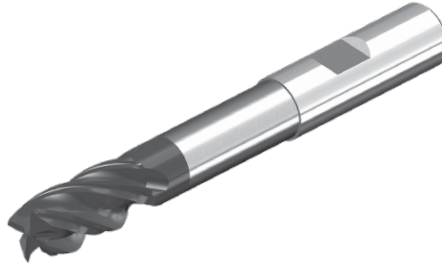

Weldon Flat ground on 3/8" and larger shanks

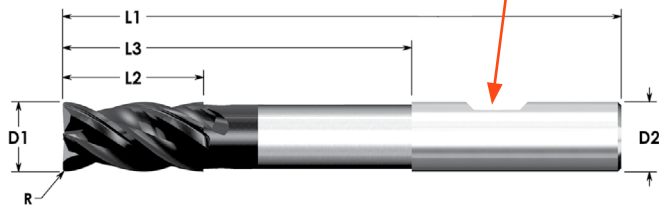

End Mills Coated with:

AlTiN

Metric sizes also available.

VLR	Cutter Diameter (D1)	Flute Length (L2)	Tool Radius (R)	Overall Reach (L3)	Overall Length (L1)
4 FLUTE Catalog No.	fraction	fraction	inch	inch	inch
3/16" Shanks – D2					
VLR-187-4X	3/16	3/8	.010	2.000	3.000
1/4" Shanks – D2					
VLR-250-4X	1/4	1/2	.020	2.500	4.000
5/16" Shanks – D2					
VLR-312-4X	5/16	5/8	.020	2.625	4.000
3/8" Shanks – D2					
VLR-375-4X	3/8	3/4	.020	2.750	4.000
1/2" Shanks – D2					
VLR-500-4X	1/2	1	.030	4.500	6.000
5/8" Shanks – D2					
VLR-625-4X	5/8	1-1/4	.030	4.500	6.000
3/4" Shanks – D2					
VLR-750-4X	3/4	1-1/2	.030	4.500	6.000

For current pricing and availability please visit our website at www.micro100.com

VLR
5 Flute Variable Helix,
High Velocity, Long Reach
Reduced Neck End Mills

MICRO 100®
super carbide tools

Tolerances:
Shank Diameter: -.0001"-.0003"
Cutter Diameter:
1/4": +.000"-.002"
5/16"-1": +.000"-.003"
T.I.R. MAX: .0005"

THE
V-HEMOTH
HIGH VELOCITY VARIABLE HELIX

FEATURING:

- Variable Pitch
- High Production High Speed Milling
- Excellent Surface Finish
- Eliminates Chatter
- Reduces Machine Vibration

Page 274
for Coating
Info



Weldon Flat ground on 3/8" and larger shanks

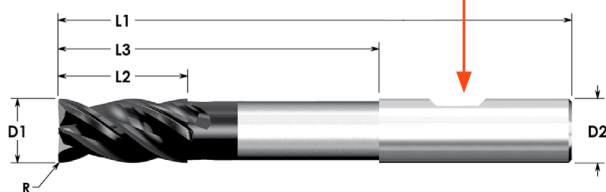

End Mills Coated with
nACRO®
(Nanotech "CR")

Metric sizes also available.

VLR		Cutter Diameter (D1)	Flute Length (L2)	Tool Radius (R)	Overall Reach (L3)	Overall Length (L1)
5 FLUTE Catalog No.						
Uncoated	Coated	fraction	fraction	inch	inch	inch
1/4" Shanks – D2						
VLR-250-5	VLR-250-5K	1/4	1/2	.000	2.500	4.000
VLR-250-5-020	VLR-250-5-020K	1/4	1/2	.020	2.500	4.000
5/16" Shanks – D2						
VLR-312-5	VLR-312-5K	5/16	5/8	.000	2.625	4.000
VLR-312-5-020	VLR-312-5-020K	5/16	5/8	.020	2.625	4.000
3/8" Shanks – D2						
VLR-375-5	VLR-375-5K	3/8	3/4	.000	2.750	4.000
VLR-375-5-020	VLR-375-5-020K	3/8	3/4	.020	2.750	4.000
1/2" Shanks – D2						
VLR-500-5	VLR-500-5K	1/2	1	.000	4.500	6.000
VLR-500-5-030	VLR-500-5-030K	1/2	1	.030	4.500	6.000
VLR-500-5-060	VLR-500-5-060K	1/2	1	.060	4.500	6.000
VLR-500-5-090	VLR-500-5-090K	1/2	1	.090	4.500	6.000
VLR-500-5-125	VLR-500-5-125K	1/2	1	.125	4.500	6.000

For current pricing and availability please visit our website at www.micro100.com

FEATURING:

- Variable Pitch
- High Production High Speed Milling
- Excellent Surface Finish
- Eliminates Chatter
- Reduces Machine Vibration

THE
V-HEMOTH
HIGH VELOCITY VARIABLE HELIX

Tolerances:
Shank Diameter: $-.0001"-.0003"$
Cutter Diameter:
1/4": $+.000"/-.002"$
5/16"-1": $+.000"/-.003"$
Corner Radius: $+0"/-.0005"$

Page 274
for Coating
Info

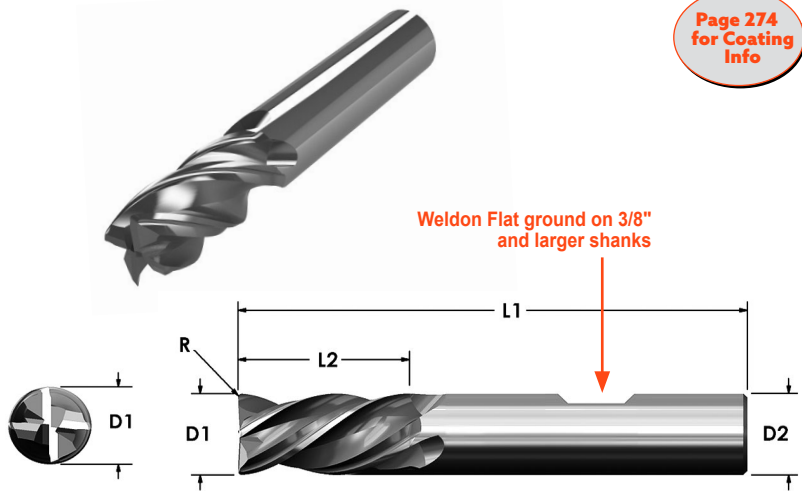

End Mills Coated with:
AlTiN

Metric sizes also available.

VHS	Cutter Diameter (D1)	Flute Length (L2)	Tool Radius (R)	Overall Length (L1)
4 FLUTE Catalog No.	inch	inch	inch	inch
1/4" Shanks – D2				
VHS-250-4X	1/4	1/2	.020	2.500
5/16" Shanks – D2				
VHS-312-4X	5/16	1/2	.020	2.500
3/8" Shanks – D2				
VHS-375-4X	3/8	5/8	.020	2.500
1/2" Shanks – D2				
VHS-500-4X	1/2	5/8	.030	3.000

For current pricing and availability please visit our website at www.micro100.com

FEATURING:

- Variable Pitch
- High Production High Speed Milling
- Excellent Surface Finish
- Eliminates Chatter
- Reduces Machine Vibration

THE
V-HEMOTH
HIGH VELOCITY VARIABLE HELIX

Tolerances:
 Shank Diameter: $-.0001"-.0003"$
 Cutter Diameter:
 1/4": $+.000"-.002"$
 5/16"-1": $+.000"-.003"$
 Corner Radius: $+0"-.0005"$

Page 274
for Coating
Info



Weldon Flat ground on 3/8" and larger shanks

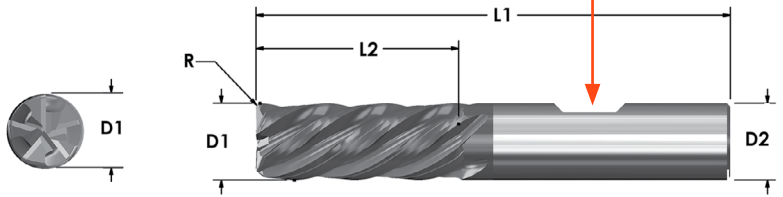

End Mills Coated with
nACRO®
 (Nanotech "CR")

Metric sizes also available.

VHS		Cutter Diameter (D1)	Flute Length (L2)	Tool Radius (R)	Overall Length (L1)
5 FLUTE Catalog No.					
Uncoated	Coated	inch	inch	inch	inch
1/4" Shanks – D2					
VHS-250-5	VHS-250-5K	1/4	1/2	.000	2.500
VHS-250-5-020	VHS-250-5-020K	1/4	1/2	.020	2.500
5/16" Shanks – D2					
VHS-312-5	VHS-312-5K	5/16	1/2	.000	2.500
VHS-312-5-020	VHS-312-5-020K	5/16	1/2	.020	2.500
3/8" Shanks – D2					
VHS-375-5	VHS-375-5K	3/8	5/8	.000	2.500
VHS-375-5-020	VHS-375-5-020K	3/8	5/8	.020	2.500
1/2" Shanks – D2					
VHS-500-5	VHS-500-5K	1/2	5/8	.000	3.000
VHS-500-5-030	VHS-500-5-030K	1/2	5/8	.030	3.000
VHS-500-5-060	VHS-500-5-060K	1/2	5/8	.060	3.000
VHS-500-5-090	VHS-500-5-090K	1/2	5/8	.090	3.000
VHS-500-5-125	VHS-500-5-125K	1/2	5/8	.125	3.000

For current pricing and availability please visit our website at www.micro100.com

FEATURING:

- Variable Pitch
- High Production High Speed Milling
- Excellent Surface Finish
- Eliminates Chatter
- Reduces Machine Vibration

THE V-HEMOTH
HIGH VELOCITY VARIABLE HELIX

Tolerances:
Shank Diameter: $-.0001"-.0003"$
Cutter Diameter:
1/4": $+.000"-.002"$
5/16"-1": $+.000"-.003"$
Corner Radius: $+0"-.0005"$

Page 274
for Coating
Info

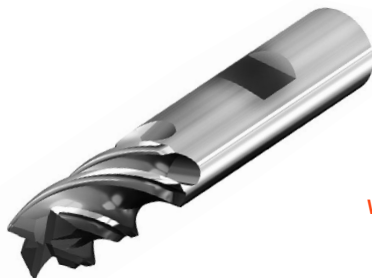

Weldon Flat ground on 3/8" and larger shanks

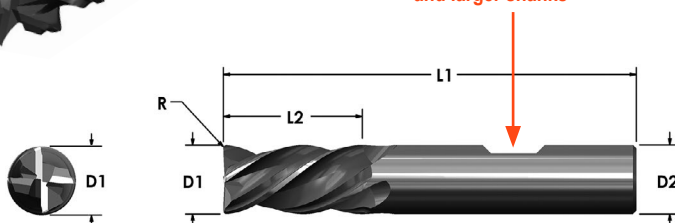

End Mills Coated with:
AlTiN

Metric sizes also available.

VHM	Cutter Diameter (D1)	Flute Length (L2)	Radius (R)	Overall Length (L1)
4 FLUTE Catalog No.	inch	inch	inch	inch
1/8" Shanks – D2				
VHM-125-4X	1/8	1/2	.010	1.500
3/16" Shanks – D2				
VHM-187-4X	3/16	5/8	.010	2.000
1/4" Shanks – D2				
VHM-250-4X	1/4	3/4	.020	2.500
5/16" Shanks – D2				
VHM-312-4X	5/16	13/16	.020	2.500
3/8" Shanks – D2				
VHM-375-4X	3/8	7/8	.020	2.500
7/16" Shanks – D2				
VHM-437-4X	7/16	1	.020	2.500
1/2" Shanks – D2				
VHM-500-4X	1/2	1	.030	3.000
VHM-5125-4X ★	1/2	1-1/4	.030	3.500
5/8" Shanks – D2				
VHM-625-4X	5/8	1-1/4	.030	3.500
3/4" Shanks – D2				
VHM-750-4X	3/4	1-1/2	.030	4.000
1" Shanks – D2				
VHM-001-4X	1	1-1/2	.030	4.000

NEW

FEATURING:

- Designed and engineered to generate maximum metal removal rates in aluminum applications.

Page 274
for Coating
Info

THE
V-HEMOTH
HIGH VELOCITY VARIABLE HELIX

Tolerances:
Shank Diameter: $-.0001''$ -. $0003''$
Cutter Diameter:
1/4": $+.000''$ -. $002''$
5/16" to 1": $+.000''$ -. $003''$
Corner Radius: $+0''$ -. $0005''$

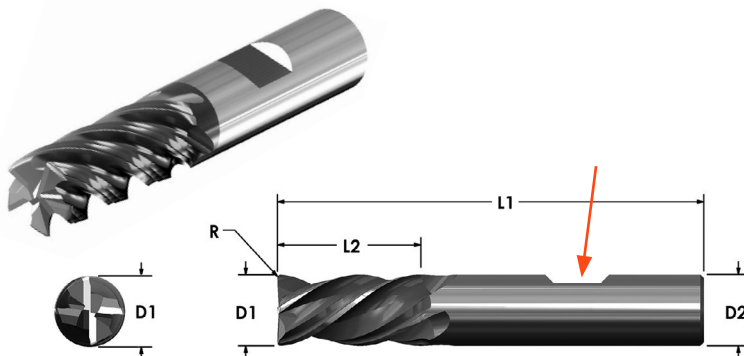

End Mills Coated with
nACro®
(Nanotech "CR")

Metric sizes also available.

VHM		Cutter Diameter (D1)	Flute Length (L2)	Radius (R)	Overall Length (L1)
5 FLUTE Catalog No.					
Uncoated	Coated	inch	inch	inch	inch
1/4" Shanks – D2					
VHM-250-5	VHM-250-5K	1/4	3/4	SHARP	2.500
VHM-250-5-020	VHM-250-5-020K	1/4	3/4	.020	2.500
5/16" Shanks – D2					
VHM-312-5	VHM-312-5K	5/16	13/16	SHARP	2.500
VHM-312-5-020	VHM-312-5-020K	5/16	13/16	.020	2.500
3/8" Shanks – D2					
VHM-375-5	VHM-375-5K	3/8	7/8	SHARP	2.500
VHM-375-5-020	VHM-375-5-020K	3/8	7/8	.020	2.500
1/2" Shanks – D2					
VHM-500-5	VHM-500-5K	1/2	1	SHARP	3.000
VHM-500-5-030	VHM-500-5-030K	1/2	1	.030	3.000
VHM-500-5-060	VHM-500-5-060K	1/2	1	.060	3.000
VHM-500-5-090	VHM-500-5-090K	1/2	1	.090	3.000
VHM-500-5-125	VHM-500-5-125K	1/2	1	.125	3.000
VHM-5125-5 -NEW	VHM-5125-5K -NEW	1/2	1-1/4	SHARP	3.500
5/8" Shanks – D2					
VHM-625-5	VHM-625-5K	5/8	1-1/4	SHARP	3.500
VHM-625-5-060	VHM-625-5-060K	5/8	1-1/4	.060	3.500
VHM-625-5-090	VHM-625-5-090K	5/8	1-1/4	.090	3.500
VHM-625-5-125	VHM-625-5-125K	5/8	1-1/4	.125	3.500
3/4" Shanks – D2					
VHM-750-5	VHM-750-5K	3/4	1-1/2	SHARP	4.000
VHM-750-5-030	VHM-750-5-030K	3/4	1-1/2	.030	4.000
VHM-750-5-060	VHM-750-5-060K	3/4	1-1/2	.060	4.000
VHM-750-5-090	VHM-750-5-090K	3/4	1-1/2	.090	4.000
VHM-750-5-125	VHM-750-5-125K	3/4	1-1/2	.125	4.000

FEATURING:

- Variable Pitch
- High Production / High Speed Milling
- Excellent Surface Finish
- Eliminates Chatter
- Reduces Machine Vibration

THE V-HEMOTH

HIGH VELOCITY VARIABLE HELIX

Tolerances:
 Shank Diameter: $-.0001"-.0003"$
 Cutter Diameter:
 1/4": $+.000"/-.002"$
 5/16"-1": $+.000"/-.003"$
 Corner Radius: $+0"/-.0005"$

Page 274
for Coating
Info

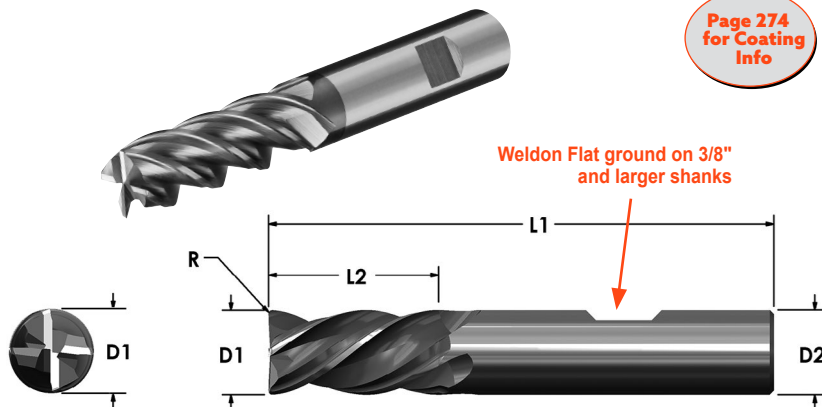

End Mills Coated with

nACRo®

(Nanotech "CR") Metric sizes also available.

AITiN – Add "X" to the end of Catalog No.

Metric sizes also available.

VLM	Cutter Diameter (D1)	Flute Length (L2)	Tool Radius (R)	Overall Length (L1)	VLM		Cutter Diameter (D1)	Flute Length (L2)	Tool Radius (R)	Overall Length (L1)
					5 FLUTE Catalog No.					
4 FLUTE Catalog No.	fraction	fraction	inch	inch	Coated	Uncoated	fraction	fraction	inch	inch
3/16" Shanks – D2										
VLM-187-4X	3/16	3/4	.010	2.500	–	–	–	–	–	–
1/4" Shanks – D2										
VLM-250-4X	1/4	1-1/8	.020	3.000	VLM-250-5	VLM-250-5K	1/4	1-1/8	.000	3.000
–	–	–	–	–	VLM-250-5-020	VLM-250-5-020K	1/4	1-1/8	.020	3.000
5/16" Shanks – D2										
VLM-312-4X	5/16	1-1/8	.020	3.000	VLM-312-5	VLM-312-5K	5/16	1-1/8	.000	3.000
–	–	–	–	–	VLM-312-5-020	VLM-312-5-020K	5/16	1-1/8	.020	3.000
3/8" Shanks – D2										
VLM-375-4X	3/8	1-1/4	.020	3.000	VLM-375-5	VLM-375-5K	3/8	1-1/4	.000	3.000
–	–	–	–	–	VLM-375-5-020	VLM-375-5-020K	3/8	1-1/4	.020	3.000
1/2" Shanks – D2										
VLM-500-4X	1/2	2-1/4	.030	4.500	VLM-500-5	VLM-500-5K	1/2	1-3/4	.000	4.500
–	–	–	–	–	VLM-500-5-030	VLM-500-5-030K	1/2	1-3/4	.030	4.500
–	–	–	–	–	VLM-500-5-060	VLM-500-5-060K	1/2	1-3/4	.060	4.500
–	–	–	–	–	VLM-500-5-090	VLM-500-5-090K	1/2	1-3/4	.090	4.500
–	–	–	–	–	VLM-500-5-125	VLM-500-5-125K	1/2	1-3/4	.125	4.500
5/8" Shanks – D2										
VLM-625-4X	5/8	2-1/4	.030	5.000	VLM-625-5 ♦	VLM-625-5K ♦	5/8	2-1/4	.000	5.000
3/4" Shanks – D2										
VLM-750-4X	3/4	2-1/2	.030	6.000	–	–	–	–	–	–

♦ WHILE SUPPLIES LAST - Discontinued

GEL

2 & 4 Flute, Center Cutting, 30°
Helix, Extra Long Length End Mills

MICRO 100®
super carbide tools

Page 274
for Coating
Info

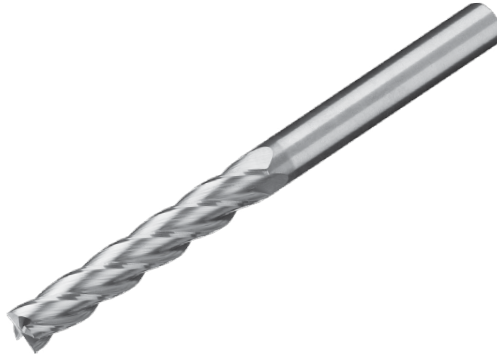

Tolerances:
Shank Diameter: $-.0001''-.0003''$
Cutter Diameter:
3/16"-1/4": $+.000''/-.002''$
5/16"-1": $+.000''/-.003''$
Corner Radius: $+0''/-.0005''$

D

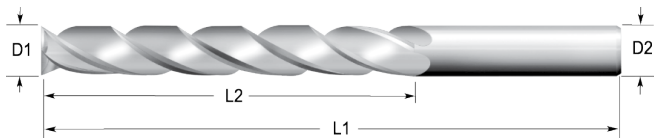

AITiN – Add “X” to the end of Catalog No.
Metric sizes also available.

GEL		Cutter Diameter (D1)	Flute Length (L2)	Overall Length (L1)
2 FLUTE Catalog No.	4 FLUTE Catalog No.			
3/16" Shanks - D2		inch	inch	inch
GEL-187-2	GEL-187-4	3/16	1-1/8	3.000
1/4" Shanks - D2				
GEL-250-2	GEL-250-4	1/4	1-1/2	4.000
5/16" Shanks - D2				
GEL-312-2 ♦	GEL-312-4	5/16	1-5/8	4.000
3/8" Shanks - D2				
GEL-375-2	GEL-375-4	3/8	1-3/4	4.000
1/2" Shanks - D2				
GEL-500-2	GEL-500-4	1/2	3	6.000

♦ WHILE SUPPLIES LAST - Discontinued

For current pricing and availability please visit our website at www.micro100.com

Neck diameter is reduced .020" on all sizes for required clearance in long reach applications.



Tolerances:
Shank Diameter: -.0001"--.0003"
Cutter Diameter:
3/16"-1/4": +.000"/-.002"
5/16"-1": +.000"/-.003"
Corner Radius: +0"/-.0005"

Page 274
for Coating
Info

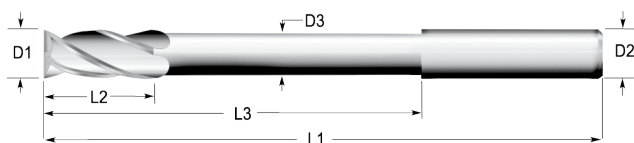

AITiN – Add “X” to the end of Catalog No.

Metric sizes also available.

GLR		Cutter Diameter (D1)	Flute Length (L2)	Reduced Neck Diameter (D3)	Reduced Neck Length (L3)	Overall Length (L1)
2 FLUTE Catalog No.	4 FLUTE Catalog No.					
3/16" Shanks – D2						
GLR-187-2	GLR-187-4	3/16	3/8	.167	2	3.000
1/4" Shanks – D2						
GLR-250-2	GLR-250-4	1/4	1/2	.230	2-1/2	4.000
5/16" Shanks – D2						
-	GLR-312-4	5/16	5/8	.292	2-5/8	4.000
3/8" Shanks – D2						
GLR-375-2	GLR-375-4	3/8	3/4	.355	2-3/4	4.000
7/16" Shanks – D2						
-	GLR-437-4	7/16	1	.417	4-1/2	6.000
1/2" Shanks – D2						
-	GLR-500-4	1/2	1	.480	4-1/2	6.000
5/8" Shanks – D2						
GLR-625-2 ♦	-	1/2	1	.605	4-1/2	6.000

♦ WHILE SUPPLIES LAST - Discontinued

For current pricing and availability please visit our website at www.micro100.com

Page 274
for Coating
Info



Tolerances:
Shank Diameter: $-.0001''$ -. $0003''$
Small Diameter: $+.003''$ - $0''$
T.I.R. MAX: $.0005''$

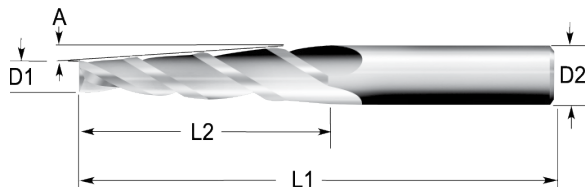

AITiN – Add “X” to the end of Catalog No.
Metric sizes also available.

TSM	Cutter Diameter (D1)	Flute Length (L2)	Angle Per Side	Overall Length (L1)
3 FLUTE Catalog No.	fraction	fraction	degree	inch
1/4" Shanks - D2				
TSM-250-0 ♦	1/8	1/2	1°	2.500
TSM-250-1 ♦	1/8	1/2	1° 30'	2.500
TSM-250-3 ♦	1/8	1/2	3°	2.500
TSM-250-5 ♦	1/8	1/2	5°	2.500
TSM-250-7 ♦	1/8	1/2	7°	2.500
3/8" Shanks - D2				
TSM-375-0 ♦	3/16	3/4	1°	2.500
TSM-375-1 ♦	3/16	3/4	1° 30'	2.500
TSM-375-3 ♦	5/32	3/4	3°	2.500
TSM-375-5 ♦	1/8	3/4	5°	2.500
TSM-375-7 ♦	5/32	3/4	7°	2.500

♦ WHILE SUPPLIES LAST - Discontinued

For current pricing and availability please visit our website at www.micro100.com

Page 274
for Coating
Info

Tolerances:
Shank Diameter: $-.0001"/-.0003"$
Radius: $+0"/-.0005"$

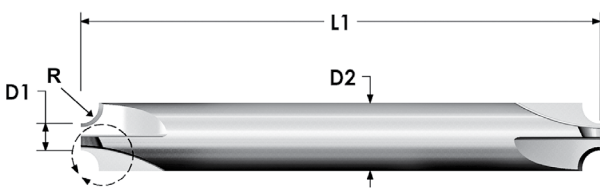
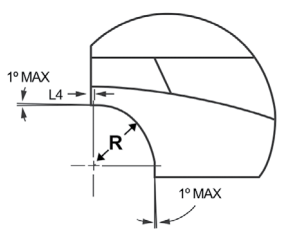

D

AITiN – Add “X” to the end of Catalog No.

Metric sizes also available.

CRE 3 FLUTE Catalog No.	Minor Diameter (D1) inch	Radius (R) inch	Overall Length (L1) inch	Max Lead In (L4) inch
1/8" Shanks - D2				
CRE-125-010	.060	.0100	2.000	.005
CRE-125-015	.060	.0156	2.000	.005
CRE-125-020	.060	.0200	2.000	.005
CRE-125-025	.060	.0250	2.000	.005
CRE-125-030	.060	.0300	2.000	.005
CRE-125-031	.060	.0312	2.000	.005
3/16" Shanks - D2				
CRE-187-035	.060	.0350	2.000	.005
CRE-187-040	.060	.0400	2.000	.005
CRE-187-045	.060	.0450	2.000	.005
CRE-187-047	.060	.0469	2.000	.005
CRE-187-050	.060	.0500	2.000	.005
CRE-187-055	.060	.0550	2.000	.005
CRE-187-060	.060	.0600	2.000	.005
CRE-187-062	.060	.0625	2.000	.005
1/4" Shanks - D2				
CRE-250-070	.060	.0700	2.500	.005
CRE-250-075	.060	.0750	2.500	.005
CRE-250-078	.060	.0781	2.500	.005
CRE-250-080	.060	.0800	2.500	.005
CRE-250-090	.060	.0900	2.500	.005
CRE-250-093	.060	.0938	2.500	.005

CRE 3 FLUTE Catalog No.	Minor Diameter (D1) inch	Radius (R) inch	Overall Length (L1) inch	Max Lead In (L4) inch
5/16" Shanks - D2				
CRE-312-100	.060	.1000	2.500	.005
CRE-312-109	.060	.1094	2.500	.005
CRE-312-125	.060	.1250	2.500	.005
3/8" Shanks - D2				
CRE-375-140	.060	.1406	2.500	.005
CRE-375-156	.060	.1562	2.500	.005
1/2" Shanks - D2				
CRE-500-171	.120	.1718	3.000	.010
CRE-500-187	.120	.1875	3.000	.010
5/8" Shanks - D2				
CRE-625-203	.120	.2031	3.500	.010
CRE-625-218	.120	.2188	3.500	.010
CRE-625-234	.120	.2344	3.500	.010
CRE-625-250	.120	.2500	3.500	.010
3/4" Shanks - D2				
CRE-750-281	.120	.2812	4.000	.010
CRE-750-312	.120	.3125	4.000	.010
1" Shanks - D2				
CRE-001-375	.120	.3750	4.000	.010
CRE-001-437	.120	.4370	4.000	.010

For current pricing and availability please visit our website at www.micro100.com

DM

2 & 4 flute, 90° & 120°

Included Point Angle, Drill Mills



FEATURING:

- Multi-purpose Drill-Mills for:

- Drilling
- Milling
- Chamfering
- Countersinking



Tolerances:
 Shank Diameter: $-.0001''-.0003''$
 Cutter Diameter:
 1/8"-1/4": $0''-.002''$
 5/16"-3/4": $0''-.003''$
 T.I.R. MAX: $.0005''$

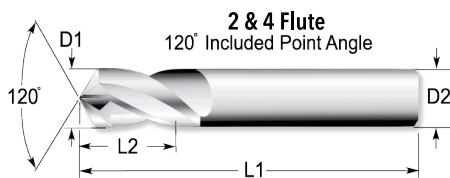
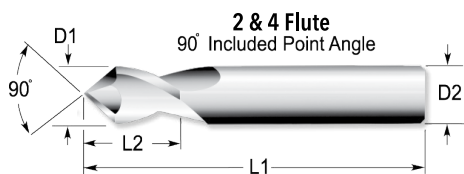

AITiN – Add “X” to the end of Catalog No.

Metric sizes also available.

DM				Cutter Diameter (D1)	Flute Length (L2)	Overall Length (L1)
2 FLUTE Catalog No. 90°	4 FLUTE Catalog No. 90°	2 FLUTE Catalog No. 120°	4 FLUTE Catalog No. 120°			
1/8" Shanks - D2						
DM-125-290	DM-125-490	DM-125-2120	DM-125-4120	1/8	1/2	1.500
3/16" Shanks - D2						
DM-187-290	DM-187-490	DM-187-2120	DM-187-4120	3/16	5/8	2.000
1/4" Shanks - D2						
DM-250-290	DM-250-490	DM-250-2120	DM-250-4120	1/4	3/4	2.500
5/16" Shanks - D2						
DM-312-290	DM-312-490	DM-312-2120	DM-312-4120	5/16	13/16	2.500
3/8" Shanks - D2						
DM-375-290	DM-375-490	DM-375-2120	DM-375-4120	3/8	1	2.500
7/16" Shanks - D2						
-	-	DM-437-2120 ♦	DM-437-4120 ♦	7/16	1	2.500
1/2" Shanks - D2						
DM-500-290	DM-500-490	DM-500-2120	DM-500-4120	1/2	1	3.000
5/8" Shanks - D2						
DM-625-290	DM-625-490	DM-625-2120	DM-625-4120	5/8	1-1/4	3.500
3/4" Shanks - D2						
DM-750-290	DM-750-490	DM-750-2120	DM-750-4120	3/4	1-1/2	4.000

♦ WHILE SUPPLIES LAST - Discontinued



FEATURING:

- These precision miniature ball nose end mills are highly wear resistant and are ideal for milling applications in hardened steels, graphites, aluminum alloys, as well as composite materials.
- Up to 12X reach.
- Machine Hardened Materials 45-68 Rc.
- Extra Fine Carbide End Mills Engineered for Hard Milling Applications.



Tolerances:
 Shank Diameter: $-.0001''$ - $-.0003''$
 D1: $+0''$ - $-.0005''$
 R: $+0''$ - $-.0005''$
 T.I.R. MAX: $.0005''$
Longer necks are reduced neck

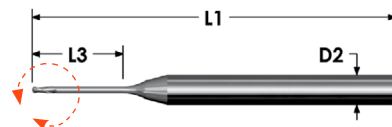
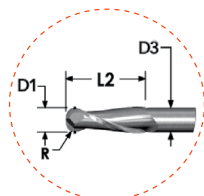

End Mills coated with:

nACRO[®]
 (Nanotech "CR")

BEF		Cutter Diameter (D1)	Length of Cut (L2)	Neck Length (L3)	Reduced Neck Diameter (D3)	Overall Length (L1)
2 FLUTE Catalog No.	3 FLUTE Catalog No.					
1/8" Shanks - D2						
BEF-010-015	-	.0100	.015	N/A	N/A	1.500
BEF-015-023	-	.0150	.023	N/A	N/A	1.500
BEF-015-100	-	.0150	.023	.100	.014	1.500
BEF-015-200	-	.0150	.023	.200	.014	1.500
BEF-020-030	BEF-020-030-3	.0200	.030	N/A	N/A	1.500
BEF-020-150	BEF-020-150-3	.0200	.030	.150	.019	1.500
BEF-020-250	BEF-020-250-3	.0200	.030	.250	.019	1.500
BEF-025-038	BEF-025-038-3	.0250	.038	N/A	N/A	1.500
BEF-025-150	BEF-025-150-3	.0250	.038	.150	.024	1.500
BEF-025-250	BEF-025-250-3	.0250	.038	.250	.024	1.500
BEF-030-045	BEF-030-045-3	.0300	.045	N/A	N/A	1.500
BEF-030-100	BEF-030-100-3	.0300	.045	.100	.028	1.500
BEF-030-200	BEF-030-200-3	.0300	.045	.200	.028	1.500
BEF-030-375	BEF-030-375-3	.0300	.045	.375	.028	1.500
BEF-031-047	BEF-031-047-3	.0310	.047	N/A	N/A	1.500
BEF-031-100	BEF-031-100-3	.0310	.047	.100	.029	1.500
BEF-031-200	BEF-031-200-3	.0310	.047	.200	.029	1.500
BEF-031-375	BEF-031-375-3	.0310	.047	.375	.029	1.500
BEF-035-053	BEF-035-053-3	.0350	.053	N/A	N/A	1.500
BEF-035-150	BEF-035-150-3	.0350	.053	.150	.033	1.500
BEF-035-250	BEF-035-250-3	.0350	.053	.250	.033	1.500
BEF-035-400	BEF-035-400-3	.0350	.053	.400	.033	1.500
BEF-040-060	BEF-040-060-3	.0400	.060	N/A	N/A	1.500
BEF-040-150	BEF-040-150-3	.0400	.060	.150	.038	1.500
BEF-040-250	BEF-040-250-3	.0400	.060	.250	.038	1.500
BEF-040-500	BEF-040-500-3	.0400	.060	.500	.038	1.500
BEF-045-068	BEF-045-068-3	.0450	.068	N/A	N/A	1.500
BEF-045-150	BEF-045-150-3	.0450	.068	.150	.043	1.500
BEF-045-250	BEF-045-250-3	.0450	.068	.250	.043	1.500
BEF-045-500	BEF-045-500-3	.0450	.068	.500	.043	1.500

BEF

2 & 3 Flute, Extra Fine Carbide, Hard Milling, Ball Nose, Miniature End Mills



FEATURING:

- These precision miniature ball nose end mills are highly wear resistant and are ideal for milling applications in hardened steels, graphites, aluminum alloys, as well as composite materials.
- Up to 12X reach.
- Machine Hardened Materials 45-68 Rc.
- Extra Fine Carbide End Mills Engineered for Hard Milling Applications.



Tolerances:
 Shank Diameter: $-.0001''$ -. $0003''$
 D1: $+0''$ -. $0005''$
 R: $+0''$ -. $0005''$
 T.I.R. MAX: $.0005''$

Longer necks are reduced neck

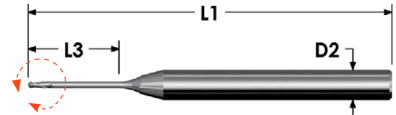
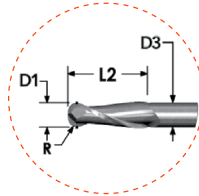

End Mills coated with:

nACRo[®]
 (Nanotech "CR")

BEF		Cutter Diameter (D1)	Length of Cut (L2)	Neck Length (L3)	Reduced Neck Diameter (D3)	Overall Length (L1)
2 FLUTE Catalog No.	3 FLUTE Catalog No.					
1/8" Shanks - D2						
BEF-047-071	BEF-047-071-3	.047	.071	N/A	N/A	1.500
BEF-047-150	BEF-047-150-3	.047	.071	.150	.045	1.500
BEF-047-250	BEF-047-250-3	.047	.071	.250	.045	1.500
BEF-047-500	BEF-047-500-3	.047	.071	.500	.045	1.500
BEF-050-075	BEF-050-075-3	.050	.075	N/A	N/A	1.500
BEF-050-200	BEF-050-200-3	.050	.075	.200	.048	1.500
BEF-050-300	BEF-050-300-3	.050	.075	.300	.048	1.500
BEF-050-550	BEF-050-550-3	.050	.075	.550	.048	1.500
BEF-060-090	BEF-060-090-3	.060	.090	N/A	N/A	1.500
BEF-060-200	BEF-060-200-3	.060	.090	.200	.056	1.500
BEF-060-350	BEF-060-350-3	.060	.090	.350	.056	1.500
BEF-060-500	BEF-060-500-3	.060	.090	.500	.056	1.500
BEF-060-750	BEF-060-750-3	.060	.090	.750	.056	2.000
BEF-062-093	BEF-062-093-3	.062	.093	N/A	N/A	1.500
BEF-062-200	BEF-062-200-3	.062	.093	.200	.058	1.500
BEF-062-350	BEF-062-350-3	.062	.093	.350	.058	1.500
BEF-062-550	BEF-062-550-3	.062	.093	.550	.058	1.500
BEF-062-750	BEF-062-750-3	.062	.093	.750	.058	2.000
BEF-075-113	BEF-075-113-3	.075	.113	N/A	N/A	1.500
BEF-075-250	BEF-075-250-3	.075	.113	.250	.071	1.500
BEF-075-400	BEF-075-400-3	.075	.113	.400	.071	1.500
BEF-075-600	BEF-075-600-3	.075	.113	.600	.071	2.000
BEF-075-900	BEF-075-900-3	.075	.113	.900	.071	2.000
BEF-078-117	BEF-078-117-3	.078	.117	N/A	N/A	1.500
BEF-078-250	BEF-078-250-3	.078	.117	.250	.074	1.500
BEF-078-400	BEF-078-400-3	.078	.117	.400	.074	1.500
BEF-078-650	BEF-078-650-3	.078	.117	.650	.074	2.000
BEF-078-900	BEF-078-900-3	.078	.117	.900	.074	2.000

FEATURING:

- These precision miniature ball nose end mills are highly wear resistant and are ideal for milling applications in hardened steels, graphites, aluminum alloys, as well as composite materials.
- Up to 12X reach.
- Machine Hardened Materials 45-68 Rc.
- Extra Fine Carbide End Mills Engineered for Hard Milling Applications.



Tolerances:
Shank Diameter: $-.0001''$ - $-.0003''$
D1: $+0''$ - $-.0005''$
R: $+0''$ - $-.0005''$
T.I.R. MAX: $.0005''$

Longer necks are reduced neck

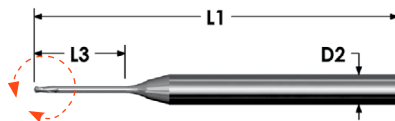
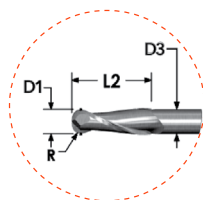

End Mills coated with:

nACRO[®]
(Nanotech "CR")

BEF	Cutter Diameter (D1)	Length of Cut (L2)	Neck Length (L3)	Reduced Neck Diameter (D3)	Overall Length (L1)
2 FLUTE	inch	inch	inch	inch	inch
Catalog No.					
1/8" Shanks - D2					
BEF-090-125	.0900	.125	N/A	N/A	1.500
BEF-090-250	.0900	.125	.250	.086	1.500
BEF-090-400	.0900	.125	.400	.086	1.500
BEF-090-650	.0900	.125	.650	.086	2.000
BEF-090-900	.0900	.125	.900	.086	2.000
BEF-093-125	.0938	.125	N/A	N/A	1.500
BEF-093-250	.0938	.125	.250	.089	1.500
BEF-093-500	.0938	.125	.500	.089	1.500
BEF-093-750	.0938	.125	.750	.089	2.000
BEF-093-1000	.0938	.125	1.000	.089	2.000
3/16" Shanks - D2					
BEF-125-125	.1250	.125	N/A	N/A	2.000
BEF-125-375	.1250	.125	.375	.121	2.000
BEF-125-750	.1250	.125	.750	.121	2.000
BEF-125-1000	.1250	.125	1.000	.121	2.000
BEF-125-1500	.1250	.125	1.500	.121	3.000

Page 274
for Coating
Info

BMR
2 Flute, Center Cutting,
30° Helix, Stub & Regular Length,
Ball Nose, Miniature End Mills

MICRO 100®
super carbide tools

Page 274
for Coating
Info

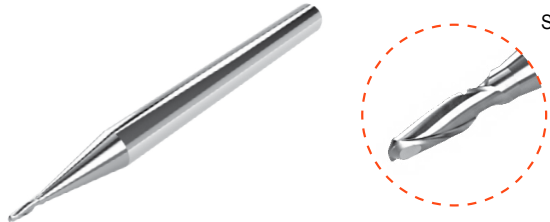

Tolerances:
Shank Diameter: $-.0001"-.0003"$
Cutter Diameter: $\pm .0005"$
T.I.R. MAX: $.0005"$

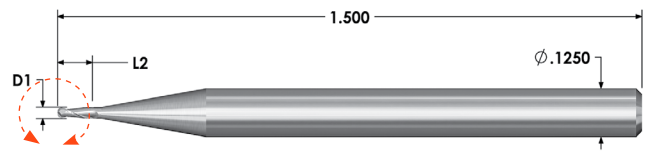

AITiN – Add “X” to the end of Catalog No.

Metric sizes also available.

BMR

2-Flute
Catalog No.

	Cutter Diameter (D1)	Flute Length (L2)	Overall Length (L1)
	inch	inch	inch
1/8" Shanks - D2			
BMR-010-2	.010	.030	1.500
BMR-011-2	.011	.033	1.500
BMR-012-2	.012	.036	1.500
BMR-013-2	.013	.039	1.500
BMR-014-2	.014	.042	1.500
BMR-015-2	.015	.045	1.500
BMR-016-2	.016	.048	1.500
BMR-017-2	.017	.051	1.500
BMR-018-2	.018	.054	1.500
BMR-019-2	.019	.057	1.500
BMR-020-2	.020	.060	1.500
BMR-021-2	.021	.063	1.500
BMR-022-2	.022	.066	1.500
BMR-023-2	.023	.069	1.500
BMR-024-2	.024	.072	1.500
BMR-025-2	.025	.075	1.500
BMR-026-2	.026	.078	1.500
BMR-027-2	.027	.081	1.500
BMR-028-2	.028	.084	1.500
BMR-030-2	.030	.090	1.500
BMR-031-2	.031	.093	1.500
BMR-032-2	.032	.096	1.500
BMR-033-2	.033	.099	1.500
BMR-034-2 ♦	.034	.102	1.500
BMR-035-2	.035	.105	1.500
BMR-040-2	.040	.120	1.500
BMR-045-2	.045	.135	1.500
BMR-050-2	.050	.150	1.500

♦ WHILE SUPPLIES LAST - Discontinued

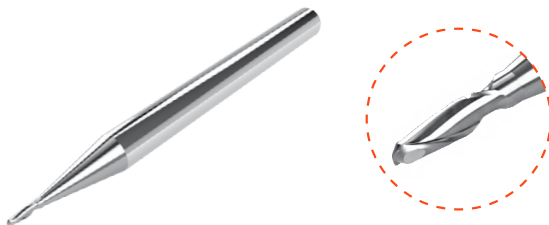

Tolerances:
Shank Diameter: -.0001"-.0003"
Cutter Diameter: ±.0005"
T.I.R. MAX: .0005"

Page 274
for Coating
Info

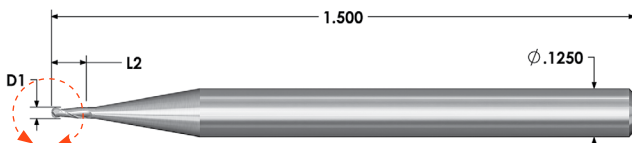

AITiN – Add “X” to the end of Catalog No.

Metric sizes also available.

BMS 2-Flute Catalog No.	Cutter Diameter (D1)	Flute Length (L2)	Overall Length (L1)
	inch	inch	inch
1/8" Shanks - D2			
BMS-010-2	.010	.015	1.500
BMS-011-2 ♦	.011	.016	1.500
BMS-012-2	.012	.018	1.500
BMS-013-2	.013	.019	1.500
BMS-014-2	.014	.021	1.500
BMS-015-2	.015	.022	1.500
BMS-016-2	.016	.024	1.500
BMS-018-2	.018	.027	1.500
BMS-019-2	.019	.028	1.500
BMS-020-2	.020	.030	1.500
BMS-021-2	.021	.031	1.500
BMS-022-2	.022	.033	1.500
BMS-023-2	.023	.034	1.500
BMS-025-2	.025	.037	1.500
BMS-026-2	.026	.039	1.500
BMS-028-2	.028	.042	1.500
BMS-030-2	.030	.045	1.500
BMS-031-2	.031	.047	1.500
BMS-032-2	.032	.048	1.500
BMS-033-2	.033	.050	1.500
BMS-034-2	.034	.051	1.500
BMS-035-2	.035	.053	1.500
BMS-040-2	.040	.060	1.500
BMS-050-2	.050	.075	1.500

♦ WHILE SUPPLIES LAST - Discontinued

ARB

2 & 3 Flute, Center Cutting 45° Ball Nose End Mills



FEATURING:

- "Stealth" cutter-profile. These high performance ball nose end mills are engineered for high speed cutting in aluminum, nonferrous and soft materials.
- The special flute geometry provides an extremely smooth and silent cutting action for an exceptional surface finish.

**Page 274
for Coating
Info**



Tolerances:
Shank Diameter: $-.0001"-.0003"$
Cutter Diameter: $1/8" - 1/4" +.000"-.002"$
 $5/16" - 1" +.000"-.003"$
T.I.R. MAX: $.0005"$

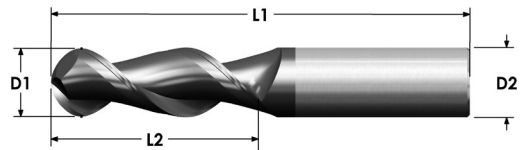

ZrN – Add "S" to the end of Catalog No.
Metric sizes also available.

ARB		Cutter Diameter (D1)	Flute Length (L3)	Overall Length (L1)
2 FLUTE Catalog No.	3 FLUTE Catalog No.			
3/16" Shanks - D2				
ARB-187-2 ♦	–	3/16	5/8	2.000
3/4" Shanks - D2				
ARB-750-2 ♦	ARB-750-3 ♦	3/4	1-1/2	4.000
1" Shanks - D2				
ARB-001-2 ♦	ARB-001-3 ♦	1	1-1/2	4.000

♦ WHILE SUPPLIES LAST - Discontinued

For current pricing and availability please visit our website at www.micro100.com

Page 274
for Coating
Info

Tolerances:

Shank Diameter: -.0001"-.0003"
Cutter Diameter:
3/16"-1/4": 0"/-.002"
5/16"-1": 0"/-.003"
T.I.R. MAX: .0005"



Neck diameter is reduced .020" on all sizes for required clearance in long reach applications.

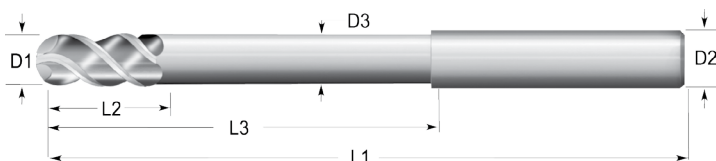

D

AITiN – Add “X” to the end of Catalog No.

Metric sizes also available.

BLR		Cutter Diameter (D1)	Flute Length (L2)	Reduced Neck Diameter (D3)	Reduced Neck Length (L3)	Overall Length (L1)
2 FLUTE Catalog No.	4 FLUTE Catalog No.	fraction	fraction	inch	fraction	inch
3/16" Shanks - D2						
BLR-187-2	BLR-187-4	3/16	3/8	.167	2	3.000
1/4" Shanks - D2						
BLR-250-2	BLR-250-4	1/4	1/2	.230	2-1/2	4.000
5/16" Shanks - D2						
BLR-312-2	BLR-312-4 ♦	5/16	5/8	.292	2-5/8	4.000
3/8" Shanks - D2						
-	BLR-375-4	3/8	3/4	.355	2-3/4	4.000
7/16" Shanks - D2						
BLR-437-2 ♦	BLR-437-4 ♦	7/16	1	.417	4-1/2	6.000
1/2" Shanks - D2						
BLR-500-2	BLR-500-4	1/2	1	.480	4-1/2	6.000
5/8" Shanks - D2						
-	BLR-625-4 ♦	5/8	1-1/4	.605	4-1/2	6.000
3/4" Shanks - D2						
BLR-750-2 ♦	-	3/4	1-1/2	.730	4-1/2	6.000
1" Shanks - D2						
BLR-001-2 ♦	BLR-001-4 ♦	1	1-1/2	.980	4-1/2	6.000

♦ WHILE SUPPLIES LAST - Discontinued

For current pricing and availability please visit our website at www.micro100.com

Tolerances:
Shank Diameter: -.0001"-.0003"
Cutter Diameter:
1/32"-1/4": 0"/-.002"
9/32"-1": 0"/-.003"
T.I.R. MAX: .0005"

Page 274
for Coating
Info

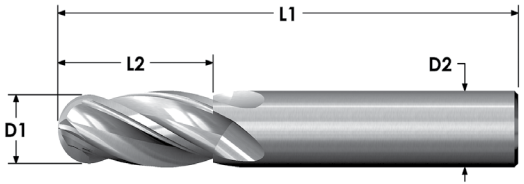

AITiN – Add “X” to the end of Catalog No.

Metric sizes also available.

BEM			Cutter Diameter (D1)	Flute Length (L2)	Overall Length (L1)
2 FLUTE Catalog No.	3 FLUTE Catalog No.	4 FLUTE Catalog No.	fraction	fraction	inch
1/8" Shanks - D2					
BEM-031-02	BEM-031-03	BEM-031-04	1/32	5/64	1.500
BEM-046-02	BEM-046-03	BEM-046-04	3/64	7/64	1.500
BEM-062-02	BEM-062-03	BEM-062-04	1/16	3/16	1.500
BEM-078-02	BEM-078-03	BEM-078-04	5/64	3/16	1.500
BEM-093-02	BEM-093-03	BEM-093-04	3/32	3/8	1.500
BEM-109-02	BEM-109-03 ♦	–	7/64	3/8	1.500
BEM-125-02	BEM-125-03	BEM-125-04	1/8	1/2	1.500
3/16" Shanks - D2					
BEM-140-02 ♦	BEM-140-03 ♦	–	9/64	1/2	2.000
BEM-156-02	BEM-156-03	BEM-156-04	5/32	9/16	2.000
BEM-171-02 ♦	–	–	11/64	5/8	2.000
BEM-187-02	BEM-187-03	BEM-187-04	3/16	5/8	2.000
1/4" Shanks - D2					
BEM-203-02 ♦	BEM-203-03 ♦	–	13/64	5/8	2.500
BEM-218-02	BEM-218-03 ♦	BEM-218-04	7/32	5/8	2.500
BEM-234-02 ♦	–	BEM-234-04 ♦	15/64	3/4	2.500
BEM-250-02	BEM-250-03	BEM-250-04	1/4	3/4	2.500
5/16" Shanks - D2					
BEM-281-02 ♦	BEM-281-03 ♦	BEM-281-04	9/32	3/4	2.500
BEM-312-02	–	BEM-312-04	5/16	13/16	2.500
3/8" Shanks - D2					
BEM-375-02	BEM-375-03	BEM-375-04	3/8	7/8	2.500

♦ WHILE SUPPLIES LAST - Discontinued

For current pricing and availability please visit our website at www.micro100.com

Tolerances:

Shank Diameter: -.0001"-.0003"

Cutter Diameter:

1/32"-1/4": 0"/-.002"

9/32"-1": 0"/-.003"

T.I.R. MAX: .0005"

Page 274
for Coating
Info

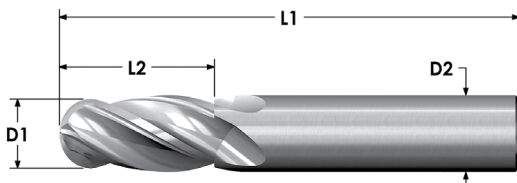

D

AITiN – Add “X” to the end of Catalog No.

Metric sizes also available.

BEM			Cutter Diameter (D1)	Flute Length (L2)	Overall Length (L1)
2 FLUTE Catalog No.	3 FLUTE Catalog No.	4 FLUTE Catalog No.			
			fraction	fraction	inch
7/16" Shanks - D2					
BEM-437-02 ♦	–	–	7/16	1	2.500
1/2" Shanks - D2					
BEM-500-02	BEM-500-03	BEM-500-04	1/2	1	3.000
9/16" Shanks - D2					
BEM-562-02 ♦	BEM-562-02 ♦	–	9/16	1-1/4	3.500
5/8" Shanks - D2					
–	–	BEM-625-04	5/8	1-1/4	3.500
3/4" Shanks - D2					
BEM-750-02 ♦	–	BEM-750-04	3/4	1-1/2	4.000
7/8" Shanks - D2					
BEM-875-02 ♦	BEM-875-03 ♦	–	7/8	1-1/2	4.000
1" Shanks - D2					
BEM-001-02 ♦	BEM-001-03 ♦	BEM-001-04	1	1-1/2	4.000

♦ WHILE SUPPLIES LAST - Discontinued

For current pricing and availability please visit our website at www.micro100.com

BEL
 2 & 4 Flute, Center Cutting,
 30° Helix, Extra Long Length,
 Ball Nose End Mills

MICRO 100®
 super carbide tools

Tolerances:
 Shank Diameter: $-.0001"$ -. $0003"$
 Cutter Diameter:
 3/16"-1/4": $0"/-.002"$
 5/16"-1": $0"/-.003"$
 T.I.R. MAX: $.0005"$

Page 274
 for Coating
 Info

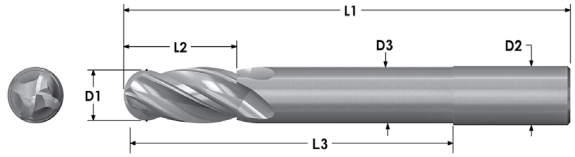

AlTiN – Add “X” to the end of
 Catalog No.

Metric sizes also available.

BEL		Cutter Diameter (D1)	Flute Length (L2)	Overall Length (L1)
2 FLUTE Catalog No.	4 FLUTE Catalog No.			
		fraction	fraction	inch
3/16" Shanks - D2				
BEL-187-2 ♦	–	3/16	1-1/8	3.000
5/16" Shanks - D2				
BEL-312-2 ♦	–	5/16	1-5/8	4.000
3/8" Shanks - D2				
BEL-375-2 ♦	–	3/8	1-3/4	4.000
7/16" Shanks - D2				
BEL-437-2 ♦	BEL-437-4 ♦	7/16	3	6.000
5/8" Shanks - D2				
BEL-625-2 ♦	BEL-625-4 ♦	5/8	3	6.000
3/4" Shanks - D2				
BEL-750-2 ♦	BEL-750-4 ♦	3/4	3	6.000
1" Shanks - D2				
BEL-001-2 ♦	BEL-001-4 ♦	1	3	6.000

♦ WHILE SUPPLIES LAST - Discontinued

For current pricing and availability please visit our website at www.micro100.com

FEATURING:

- These short flute 220° spherical ball nose end mills feature a reduced neck diameter and are ideal for copy milling and deep pocket milling applications.
- The special geometry allows inclination of up to 15° with optimal chip evacuation for increased feed rates.

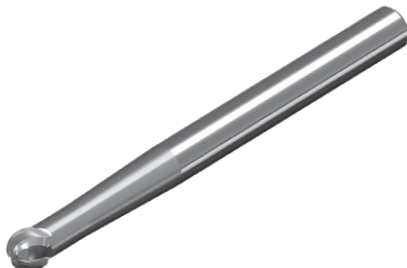

Tolerances:
 Shank Diameter: -.0001"-.0003"
 Cutter Diameter:
 1/8"-1/4": 0/--.002"
 5/16"-5/8": 0/--.003"
 T.I.R. MAX: .0005"

Page 274
for Coating
Info

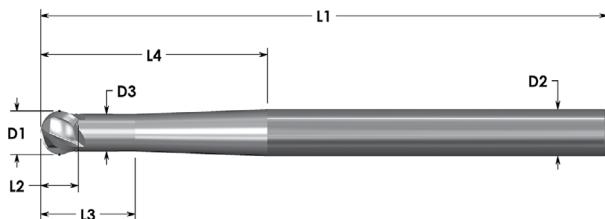

AlTiN – Add “X” to the end of Catalog No.

Metric sizes also available.

SBM			Cutter Diameter (D1)	Flute Length (L2)	Neck Diameter (D3)	Neck Length (L3)	Reduced Neck Length (L4)	Radius	Overall Length (L1)
2 FLUTE Catalog No.	3 FLUTE Catalog No.	4 FLUTE Catalog No.	fraction	inch	inch	inch	inch	inch	inch
1/4" Shanks - D2									
-	-	SBM-125-4	1/8	.100	.100	.250	1.100	.0620	3.000
SBM-187-2 ♦	-	SBM-187-4							
SBM-250-2	SBM-250-3	SBM-250-4	1/4	.200	.200	.500	1.200	.1250	3.000
5/16" Shanks - D2									
SBM-312-2 ♦	-	SBM-312-4	5/16	.250	.250	.600	1.200	.1562	4.000
3/8" Shanks - D2									
SBM-375-2 ♦	-	SBM-375-4	3/8	.300	.300	.800	1.200	.1875	4.000
1/2" Shanks - D2									
SBM-500-2	SBM-500-3 ♦	SBM-500-4	1/2	.400	.400	.900	1.200	.2500	4.000

♦ WHILE SUPPLIES LAST - Discontinued

For current pricing and availability please visit our website at www.micro100.com

Guaranteed Test Tool Options

The **GUARANTEED TEST TOOL OPTION** from MICRO 100 allows you to test our product that is new to you before you buy it! Our Try-Before-You-Buy program is usually run through putting together your request with one of our Authorized MICRO 100 Distributors and our local field sales representative.

We want our local field sales representative involved with your test so that he or she can assist you with offering suggestions for running MICRO 100 solid carbide tools at their "optimum" performance levels.

After the test is complete, we provide a simple, single page test form for you to fill out. The data is essential for MICRO 100 and your performance evaluation and comments are of equal importance.

Contact your local Authorized MICRO 100 Super Carbide Tools Distributor for more details on how you can place a "GTO" with them, or contact our Customer Service Team.

Our Customer Service Team is knowledgeable, courteous, and will either know the answers to your questions outright, or they will quickly do research with our staff to get solutions for your specific machining application.



Contact your local Authorized **MICRO 100** Super Carbide Tools Distributor for more details on...
 the "Guarantee Test Option" Program"...Today!

MICRO 100®
super carbide tools

*...are Highly Shock Resistant,
will NOT chip or break under
normal machining conditions.*

UNEXCELLED IN INTERRUPTED CUTTING!

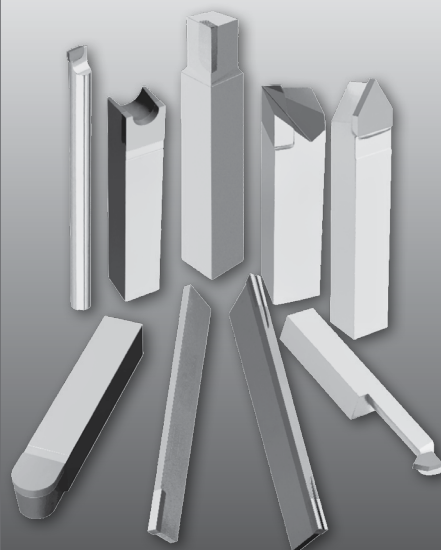

E

Brazed Screw Machine Tools

Turning, Forming, Threading & Cut-Off Tools

Double Ended "T" Cut-Off Blades

Cut-Off Blades for Brown & Sharpe

Cut-Off Blades for P & W Holders

Cut-Off Blades for Dovetail Slot Holders

Full Radius Concave and Convex Tools

Concave and Convex Tools

Groove, Relief, and O.D. Cutting Tools

Box Turning Tools.



**WILL NOT CHIP OR BREAK
UNDER NORMAL MACHINING CONDITIONS**



Styles AR & AL

page 164

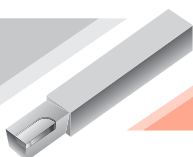

Styles IDRT & IDLT

page 167



Styles BR & BL

page 164

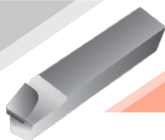

Style CT

page 167



Style C

page 165



Full Radius Concave

Style CRT

page 168



Style D

page 165

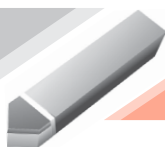

Full Radius Convex

Style FRT

page 168

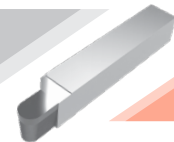

Style E

page 166



Concave Radius

Styles RAD & RAL

page 169



Style ER & EL

page 166



Convex Radius

Styles RXD & RXL

page 170



E

Style GR Brazed Grooving Tools
Groove Relief and O.D. Cutting
page 171

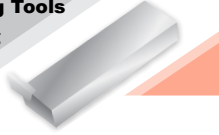

Brazed Cut-Off Blades
Double End "T" blades
page 173



Style GS Brazed Grooving Tools
Groove Relief and O.D. Cutting
page 171

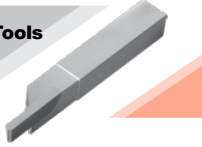

Brazed Cut-Off Blades
Double End "T" blades
with "V" Groove
page 174



Styles BT & BTL
Box-turning
page 172

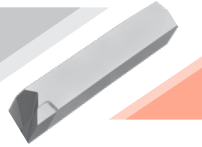

Brazed Screw Machine Tools
Turning, Forming & Cut-Off
page 175

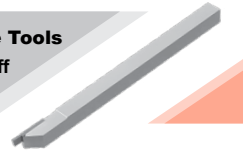

Brazed Cut-Off Blades CR/CL
Brown & Sharpe automatics, P&W
Holders, and Dovetail Slot Holders
page 173



Brazed Boring Tools
Style TRG
page 176

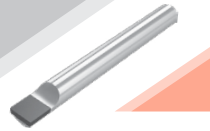

Brazed Boring Tools & Sets
Style TBB & TBBL
page 177



MICRO-GRAIN CARBIDE + PLUS
featuring Superior Rupture Strength and
Machining Versatility!

Styles AR/AL

Quantity Price Breaks Available

- 1 to 5 pices
- 6 to 11 pieces
- 12 to 23 pieces
- 24 to 47 pieces
- 48 or More

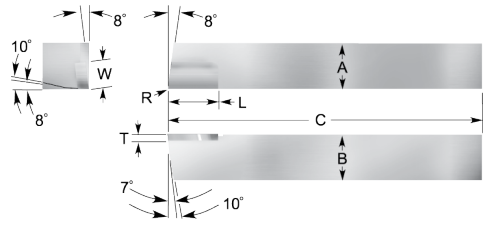

AR Catalog No.	AL Catalog No.	Tip				Overall Length (C) inch
		(W) fraction	(L) fraction	(T) fraction	(R) fraction	
1/4" Shanks - A/B						
AR-4	AL-4	3/16	1/4	1/16	1/64	2.000
5/16" Shanks - A/B						
AR-5	AL-5	1/4	5/16	1/16	1/64	2.250
3/8" Shanks - A/B						
AR-6	AL-6	1/4	3/8	1/8	1/64	2.500
7/16" Shanks - A/B						
AR-7	AL-7	1/4	7/16	1/8	1/32	3.000
1/2" Shanks - A/B						
AR-8	AL-8	1/4	1/2	1/8	1/32	3.500
5/8" Shanks - A/B						
AR-10	AL-10	3/8	5/8	5/32	1/32	4.000
3/4" Shanks - A/B						
AR-12	AL-12	7/16	3/4	3/16	1/32	4.500

Styles BR / BL

Quantity Price Breaks Available

- 1 to 5 pices
- 6 to 11 pieces
- 12 to 23 pieces
- 24 to 47 pieces
- 48 or More

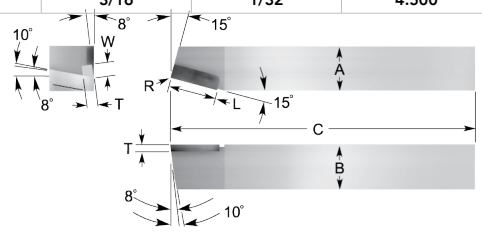
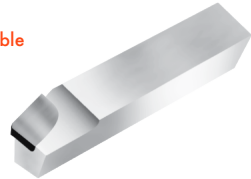

BR Catalog No.	BL Catalog No.	Tip				Overall Length (C) inch
		(W) fraction	(L) fraction	(T) fraction	(R) fraction	
3/8" Shanks - A/B						
BR-6	BL-6	1/4	1/2	1/8	1/64	2.500
7/16" Shanks - A/B						
BR-7	BL-7	1/4	1/2	1/8	1/32	3.000
1/2" Shanks - A/B						
BR-8	BL-8	1/4	5/8	1/8	1/32	3.500
5/8" Shanks - A/B						
BR-10	BL-10	3/8	3/4	5/32	1/32	4.000
3/4" Shanks - A/B						
BR-12	BL-12	7/16	13/16	3/16	1/32	4.500

Style C

Quantity Price Breaks Available

- 1 to 5 pieces
- 6 to 11 pieces
- 12 to 23 pieces
- 24 to 47 pieces
- 48 or More

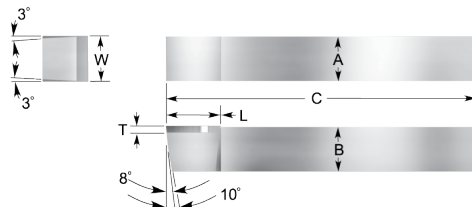

C Catalog No.	Tip			Overall Length (C) inch
	(W)	(L)	(T)	
	fraction	fraction	fraction	
1/4" Shanks - A/B				
C-4	1/4	1/4	1/16	2.000
5/16" Shanks - A/B				
C-5	5/16	5/16	1/16	2.250
3/8" Shanks - A/B				
C-6	3/8	3/8	1/32	2.500
7/16" Shanks - A/B				
C-7	7/16	7/16	1/8	3.000
1/2" Shanks - A/B				
C-8	1/2	1/2	3/32	3.500
5/8" Shanks - A/B				
C-10	5/8	5/8	5/32	4.000
3/4" Shanks - A/B				
C-12	3/4	3/4	3/16	4.500

Style D

Quantity Price Breaks Available

- 1 to 5 pieces
- 6 to 11 pieces
- 12 to 23 pieces
- 24 to 47 pieces
- 48 or More

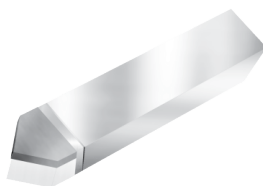

D Catalog No.	Tip			Overall Length (C) inch
	(W)	(L)	(T)	
	fraction	fraction	fraction	
1/4" Shanks - A/B				
D-4	1/4	5/16	1/16	2.000
5/16" Shanks - A/B				
D-5	5/16	3/8	3/32	2.250
3/8" Shanks - A/B				
D-6	3/8	1/2	3/32	2.500
7/16" Shanks - A/B				
D-7	7/16	1/2	3/32	3.000
1/2" Shanks - A/B				
D-8	1/2	1/2	1/8	3.500
5/8" Shanks - A/B				
D-10	5/8	5/8	5/32	4.000
3/4" Shanks - A/B				
D-12	3/4	3/4	3/16	4.500

Style E

Quantity Price Breaks Available

- 1 to 5 pieces
- 6 to 11 pieces
- 12 to 23 pieces
- 24 to 47 pieces
- 48 or More

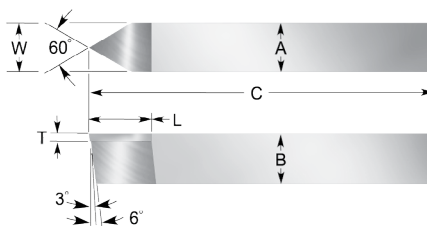

E Catalog No.	Tip			Overall Length (C) inch
	(W) fraction	(L) fraction	(T) fraction	
5/16" Shanks - A/B				
E-5	5/16	3/8	3/32	2.250
3/8" Shanks - A/B				
E-6	3/8	1/2	3/32	2.500
1/2" Shanks - A/B				
E-8	1/2	1/2	1/8	3.500
5/8" Shanks - A/B				
E-10	5/8	5/8	5/32	4.000
3/4" Shanks - A/B				
E-12	3/4	3/4	3/16	4.500

Styles ER/EL

Quantity Price Breaks Available

- 1 to 5 pieces
- 6 to 11 pieces
- 12 to 23 pieces
- 24 to 47 pieces
- 48 or More

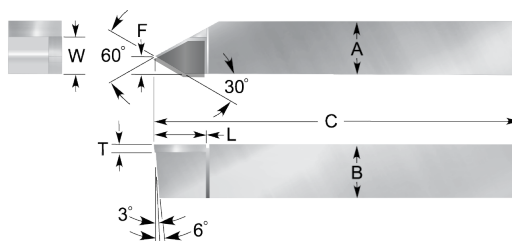

ER Catalog No.	EL Catalog No.	Tip				Overall Length (C) inch
		(W) fraction	(L) fraction	(F) fraction	(T) fraction	
5/16" Shanks - A/B						
ER-5	EL-5	1/4	3/8	1/16	3/32	2.250
3/8" Shanks - A/B						
ER-6	EL-6	1/4	3/8	1/16	3/32	2.500
1/2" Shanks - A/B						
ER-8	EL-8	5/16	5/8	3/32	1/8	3.500
5/8" Shanks - A/B						
ER-10	EL-10	5/16	5/8	3/32	1/8	4.000
3/4" Shanks - A/B						
ER-12	EL-12	3/8	3/4	1/8	5/32	4.500

For current pricing and availability please visit our website at www.micro100.com

Styles IDRT/IDLT

Quantity Price Breaks Available

- 1 to 5 pieces
- 6 to 11 pieces
- 12 to 23 pieces
- 24 to 47 pieces
- 48 or More

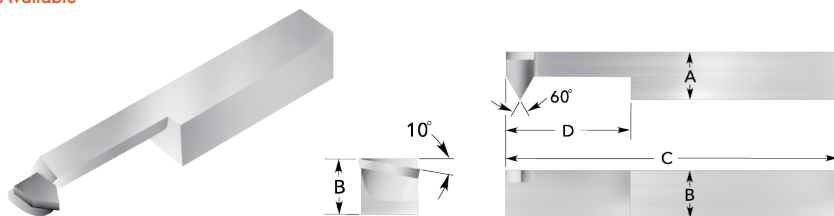

IDRT	IDLT	Minimum Thread Diameter	Neck Length (D)	Overall Length (C)
RIGHT Hand Catalog No.	LEFT Hand Catalog No.	fraction	fraction	inch
3/8" Shanks - A/B				
IDRT-60	IDLT-60	.450	1/2	2.500
IDRT-61	IDLT-61	.450	1	2.500
1/2" Shanks - A/B				
IDRT-80	IDLT-80	.575	3/4	3.500
IDRT-81	IDLT-81	.575	1-1/4	3.500

E

Style CT

Quantity Price Breaks Available

- 1 to 5 pieces
- 6 to 11 pieces
- 12 to 23 pieces
- 24 to 47 pieces
- 48 or More

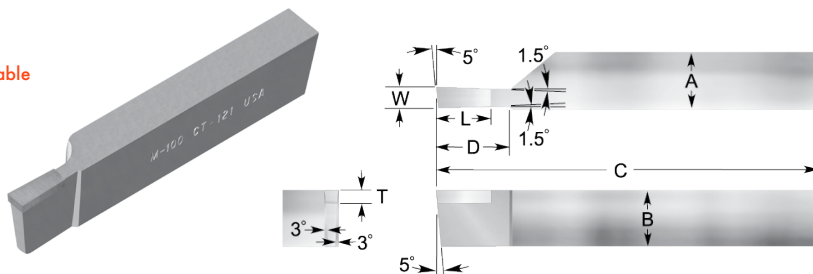

CT Catalog No.	Shank				Tip		
	(A)	(B)	(C)	(D)	(T)	(W)	(L)
	fraction	fraction	inch	fraction	fraction	fraction	fraction
1/2" Shanks - A/B							
CT-120	1/2	1	5.000	1	3/16	5/16	7/16
CT-121	1/2	1	5.000	1	1/8	1/4	3/4
CT-122	1/2	1	5.000	13/16	1/8	3/16	3/4
5/8" Shanks - A/B							
CT-130	5/8	1-1/4	5.000	1-1/4	3/16	3/8	1/2
3/4" Shanks - A/B							
CT-140	3/4	1-1/2	6.000	1-1/4	3/16	3/8	5/8

For current pricing and availability please visit our website at www.micro100.com

Brazed Radius Tools

Full Radius Concave Tools

Full Radius Convex Tools

Full Radius Concave

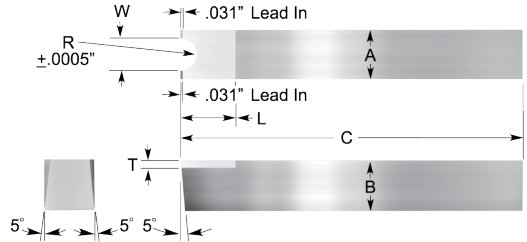
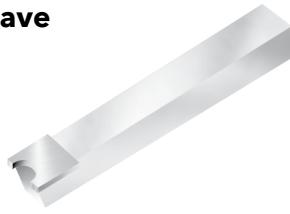

CRT Catalog No.	Tip				Overall Length (C) inch
	(W) fraction	(L) fraction	(T) fraction	(R) fraction	
3/8" Shanks - A/B					
CRT-1	1/16	3/8	3/32	1/32	2.500
CRT-2	1/8	3/8	3/32	1/16	2.500
CRT-3	3/16	3/8	3/32	3/32	2.500
1/2" Shanks - A/B					
CRT-4	1/4	1/2	1/8	1/8	3.500
CRT-6	3/8	1/2	1/8	3/16	3.500
3/4" Shanks - A/B					
CRT-8	1/2	3/4	3/16	1/4	4.500

Full Radius Convex

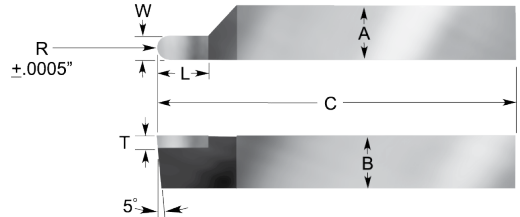

FRT Catalog No.	Tip				Overall Length (C) inch
	(W) fraction	(L) fraction	(T) fraction	(R) fraction	
3/8" Shanks - A/B					
FRT-1	1/16	3/8	3/32	1/32	2.500
FRT-2	1/8	3/8	3/32	1/16	2.500
FRT-3	3/16	3/8	3/32	3/32	2.500
FRT-4	1/4	3/8	3/32	1/8	2.500
FRT-5	5/16	3/8	3/32	5/32	2.500
1/2" Shanks - A/B					
FRT-6	3/8	3/8	1/8	3/16	3.500
FRT-8	1/2	3/8	1/8	1/4	3.500
5/8" Shanks - A/B					
FRT-10	5/8	5/8	5/32	5/16	4.000
3/4" Shanks - A/B					
FRT-12	3/4	3/4	3/16	3/8	4.500

Concave Radius

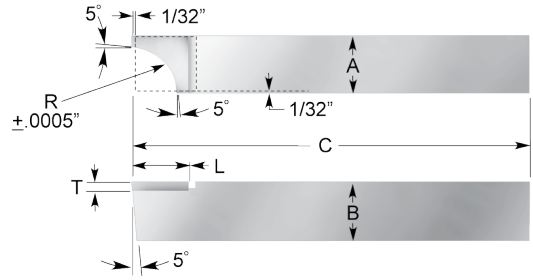

RAD Catalog No.	RAL Catalog No.	Tip			Overall Length (C) inch
		(R) fraction	(L) fraction	(T) fraction	
3/8" Shanks - A/B					
RAD-1	RAL-1	1/32	3/8	3/32	2.500
RAD-2	RAL-2	1/16	3/8	3/32	2.500
RAD-3	RAL-3	3/32	3/8	3/32	2.500
RAD-4	RAL-4	1/8	3/8	3/32	2.500
RAD-5	RAL-5	5/32	3/8	3/32	2.500
RAD-6	RAL-6	3/16	3/8	3/32	2.500
RAD-7	RAL-7	7/32	3/8	3/32	2.500
RAD-8	RAL-8	1/4	3/8	3/32	2.500
1/2" Shanks - A/B					
RAD-9	RAL-9	9/32	1/2	1/8	3.500
RAD-10	RAL-10	5/16	1/2	1/8	3.500
RAD-11	RAL-11	11/32	1/2	1/8	3.500
RAD-12	RAL-12	3/8	1/2	1/8	3.500
3/4" Shanks - A/B					
RAD-13	RAL-13	13/32	3/4	3/16	4.500
RAD-14	RAL-14	7/16	3/4	3/16	4.500
RAD-15	RAL-15	15/32	3/4	3/16	4.500
RAD-16	RAL-16	1/2	3/4	3/16	4.500

* All 3/8" Square Shanks, ideal for use on Chuckers.

SETS

RAD-21	RAL-21	*Set of 4: 1/16, 1/8, 1/4, and 3/8 Radius
RAD-22	RAL-22	Set of 8: 1/32, to 1/4 Radius in 1/32 Increments.
RAD-23	RAL-23	Set of 8: 1/16, to 1/2 Radius in 1/16 Increments.
RAD-24	RAL-24	Set of 16: 1/32, to 1/2 Radius in 1/32 Increments.

For current pricing and availability please visit our website at www.micro100.com

Convex Radius

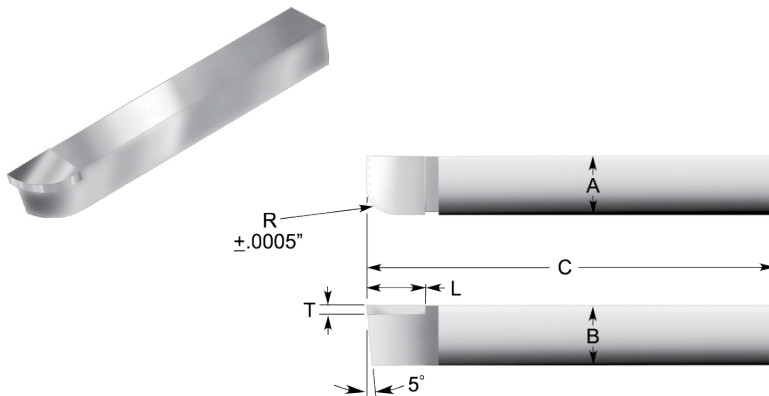

RXD Catalog No.	RXL Catalog No.	Tip			Overall Length (C) inch
		(R) fraction	(L) fraction	(T) fraction	
3/8" Shanks - A/B					
RXD-1	RXL-1	1/32	3/8	3/32	2.500
RXD-2	RXL-2	1/16	3/8	3/32	2.500
RXD-3	RXL-3	3/32	3/8	3/32	2.500
RXD-4	RXL-4	1/8	3/8	3/32	2.500
RXD-5	RXL-5	5/32	3/8	3/32	2.500
RXD-6	RXL-6	3/16	3/8	3/32	2.500
RXD-7	RXL-7	7/32	3/8	3/32	2.500
RXD-8	RXL-8	1/4	3/8	3/32	2.500
1/2" Shanks - A/B					
RXD-9	RXL-9	9/32	1/2	1/8	3.500
RXD-10	RXL-10	5/16	1/2	1/8	3.500
RXD-11	RXL-11	11/32	1/2	1/8	3.500
RXD-12	RXL-12	3/8	1/2	1/8	3.500
3/4" Shanks - A/B					
RXD-13	RXL-13	13/32	3/4	3/16	4.500
RXD-14	RXL-14	7/16	3/4	3/16	4.500
RXD-15	RXL-15	15/32	3/4	3/16	4.500
RXD-16	RXL-16	1/2	3/4	3/16	4.500

* All 3/8" Square Shanks, ideal for use on Chuckers.

Sets

RXD-21	RXL-21	* Set of 4: 1/16, 1/8, 1/4, and 3/8 Radius
RXD-22	RXL-22	Set of 8: 1/32, to 1/4 Radius in 1/32 Increments.
RXD-23	RXL-23	Set of 8: 1/16, to 1/2 Radius in 1/16 Increments.
RXD-24	RXL-24	Set of 16: 1/32, to 1/2 Radius in 1/32 Increments.

For current pricing and availability please visit our website at www.micro100.com

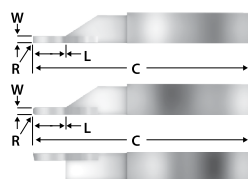
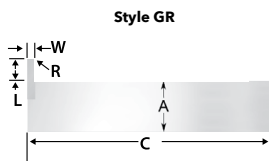

Style GS
Style GS-F

GR Catalog No.	Tip			Shank		Overall Length (C) inch
	(W)	(L)	(R)	(A)	(B)	
	inch	inch	inch	inch	inch	
3/4" Shanks						
GR-012002	.012/.014	.030	.003 max	3/4	3/8	4.000
GR-012F	.012/.014	.030	Full	3/4	3/8	4.000
GR-018002	.018/.020	.060	.003 max	3/4	3/8	4.000
GR-018F	.018/.020	.060	Full	3/4	3/8	4.000
GR-022002	.022/.024	.090	.003 max	3/4	3/8	4.000
GR-022F	.022/.024	.090	Full	3/4	3/8	4.000
GR-028002	.028/.030	.090	.003 max	3/4	3/8	4.000
GR-028F	.028/.030	.090	Full	3/4	3/8	4.000
GR-038002	.038/.040	.120	.003 max	3/4	3/8	4.000
GR-038F	.038/.040	.120	Full	3/4	3/8	4.000
GR-040002	.040/.042	.150	.003 max	3/4	3/8	4.000
GR-040F	.040/.042	.150	Full	3/4	3/8	4.000
GR-046002	.046/.048	.150	.003 max	3/4	3/8	4.000
GR-046F	.046/.048	.150	Full	3/4	3/8	4.000
GR-054002	.054/.056	.180	.003 max	3/4	3/8	4.000
GR-054F	.054/.056	.180	Full	3/4	3/8	4.000
GR-060002	.060/.062	.210	.003 max	3/4	3/8	4.000
GR-060F	.060/.062	.210	Full	3/4	3/8	4.000
GR-068002	.068/.070	.210	.003 max	3/4	3/8	4.000
GR-068F	.068/.070	.210	Full	3/4	3/8	4.000
GR-072002	.072/.074	.240	.003 max	3/4	3/8	4.000
GR-072F	.072/.074	.240	Full	3/4	3/8	4.000
GR-080002	.080/.082	.270	.003 max	3/4	3/8	4.000
GR-080F	.080/.082	.270	Full	3/4	3/8	4.000
GR-086002	.086/.088	.270	.003 max	3/4	3/8	4.000
GR-086F	.086/.088	.270	Full	3/4	3/8	4.000
GR-090002	.090/.092	.300	.003 max	3/4	3/8	4.000
GR-090F	.090/.092	.300	Full	3/4	3/8	4.000
GR-096002	.096/.098	.300	.003 max	3/4	3/8	4.000
GR-096F	.096/.098	.300	Full	3/4	3/8	4.000
GR-102002	.102/.104	.400	.003 max	3/4	3/8	4.000
GR-102F	.102/.104	.400	Full	3/4	3/8	4.000
GR-114002	.114/.116	.400	.003 max	3/4	3/8	4.000
GR-114F	.114/.116	.400	Full	3/4	3/8	4.000
GR-120002	.120/.122	.400	.003 max	3/4	3/8	4.000
GR-120F	.120/.122	.400	Full	3/4	3/8	4.000
GR-122002	.122/.124	.400	.003 max	3/4	3/8	4.000
GR-122F	.122/.124	.400	Full	3/4	3/8	4.000

GS Catalog No.	Tip			Overall Length (C) inch
	(W)	(L)	(R)	
	inch	inch	inch	
3/8" Shanks				
GS-012002	.012/.014	.030	.003 max	4.000
GS-012F	.012/.014	.030	Full	4.000
GS-018002	.018/.020	.060	.003 max	4.000
GS-018F	.018/.020	.060	Full	4.000
GS-022002	.022/.024	.090	.003 max	4.000
GS-022F	.022/.024	.090	Full	4.000
GS-028002	.028/.030	.090	.003 max	4.000
GS-028F	.028/.030	.090	Full	4.000
GS-038002	.038/.040	.120	.003 max	4.000
GS-038F	.038/.040	.120	Full	4.000
GS-040002	.040/.042	.150	.003 max	4.000
GS-040F	.040/.042	.150	Full	4.000
GS-046002	.046/.048	.150	.003 max	4.000
GS-046F	.046/.048	.150	Full	4.000
GS-054002	.054/.056	.180	.003 max	4.000
GS-054F	.054/.056	.180	Full	4.000
GS-060002	.060/.062	.210	.003 max	4.000
GS-060F	.060/.062	.210	Full	4.000
GS-068002	.068/.070	.210	.003 max	4.000
GS-068F	.068/.070	.210	Full	4.000
GS-072002	.072/.074	.240	.003 max	4.000
GS-072F	.072/.074	.240	Full	4.000
GS-080002	.080/.082	.270	.003 max	4.000
GS-080F	.080/.082	.270	Full	4.000
GS-086002	.086/.088	.270	.003 max	4.000
GS-086F	.086/.088	.270	Full	4.000
GS-090002	.090/.092	.300	.003 max	4.000
GS-090F	.090/.092	.300	Full	4.000
GS-096002	.096/.098	.300	.003 max	4.000
GS-096F	.096/.098	.300	Full	4.000
GS-102002	.102/.104	.400	.003 max	4.000
GS-102F	.102/.104	.400	Full	4.000
GS-114002	.114/.116	.400	.003 max	4.000
GS-114F	.114/.116	.400	Full	4.000
GS-120002	.120/.122	.400	.003 max	4.000
GS-120F	.120/.122	.400	Full	4.000
GS-122002	.122/.124	.400	.003 max	4.000
GS-122F	.122/.124	.400	Full	4.000

E

Styles BT/BTL

- Hardened Shanks
- Regrinding quoted upon request.

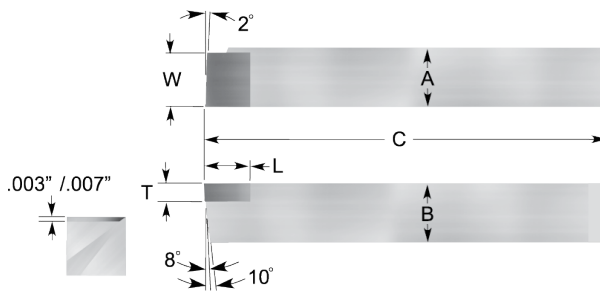
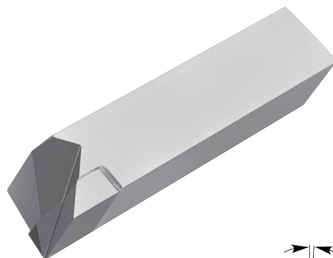

Quantity Price Breaks Available

- 1 to 5 pieces
- 6 to 11 pieces
- 12 to 23 pieces
- 24 to 47 pieces
- 48 or More

BT	BTL	Tip			Overall Length (C)
		(R)	(L)	(T)	
RIGHT Hand Catalog No.	LEFT Hand Catalog No.	fraction	fraction	fraction	inch
1/4" Shanks - A/B					
BT-4	BTL-4	3/16	1/4	1/8	1.500
5/16" Shanks - A/B					
BT-5	BTL-5	3/16	5/16	1/8	1.750
3/8" Shanks - A/B					
BT-6	BTL-6	5/16	3/8	3/16	2.000
7/16" Shanks - A/B					
BT-7	BTL-7	3/8	7/16	3/16	2.250
1/2" Shanks - A/B					
BT-8	BTL-8	3/8	1/2	3/16	2.500
9/16" Shanks - A/B					
BT-9	BTL-9	1/2	9/16	3/16	2.750
5/8" Shanks - A/B					
BT-10	BTL-10	1/2	5/8	1/4	3.000

For current pricing and availability please visit our website at www.micro100.com

Styles CR/CL

FEATURING:

- Hardened and Precision Ground Steel Blades.
- Tips are hollow ground all over for improved chip control.

Style CR



For: Vertical Slide -- Backward L.H.
Back Slide -- High Back R.H.
Front Slide -- Low Front R.H.

Style CL



For: Vertical Slide -- Forward R.H.
Back Slide -- Low Back L.H.
Front Slide -- High Front L.H.

Quantity Price Breaks Available

- 1 to 5 pieces
- 6 to 11 pieces
- 12 to 23 pieces
- 24 to 47 pieces
- 48 or More

CR	CL	Dimensions		
		(W)	(H)	(L)
RIGHT Hand Catalog No.	LEFT Hand Catalog No.	fraction	fraction	inch
1/2" Shanks				
CR-101	CL-101	5/64	1/2	4.500
CR-102	CL-102	3/32	1/2	4.500
CR-103	CL-103	1/8	1/2	4.500
11/16" Shanks				
CR-104	CL-104	3/32	11/16	5.000
CR-105	CL-105	1/8	11/16	5.000
CR-106	CL-106	5/32	11/16	5.000
CR-107	CR-107	3/16	11/16	5.000
13/16" Shanks				
CR-108	CL-108	3/32	13/16	6.000
CR-109	CL-109	1/8	13/16	6.000
CR-110	CL-110	5/32	13/16	6.000
CR-111	-	3/16	13/16	6.000
1" Shanks				
CR-113	-	3/32	1	6.000
CR-114 ♦	-	1/8	1	6.000
CR-115 ♦	-	3/16	1	6.000

♦ WHILE SUPPLIES LAST - Discontinued

For current pricing and availability please visit our website at www.micro100.com

Brazed Cut-Off Blades

Double End "T" Blades & Double End "T" Blades with V-Groove



FEATURING:

- Hardened and Precision Ground Steel Blades.
- Tips are hollow ground all over for longer tool life.
- "T" Style over entire blade length to fit all "T" type holders

Double Ended "T" Blades for Double Performance

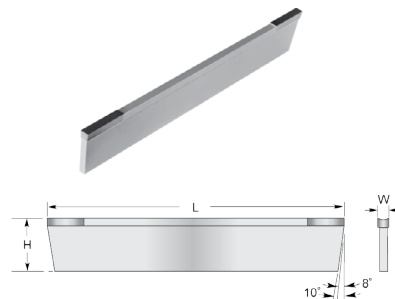
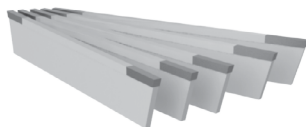

V series Double Ended T Blades with V-Groove

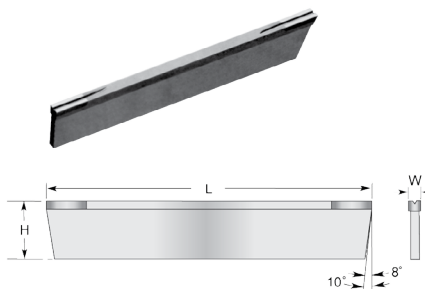
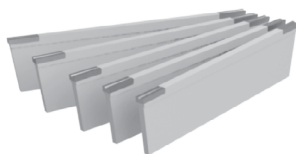

Quantity Price Breaks Available

- 1 to 5 pieces
- 6 to 11 pieces
- 12 to 23 pieces
- 24 to 47 pieces
- 48 or More

E

T		Dimensions		
REGULAR Catalog No.	V-GROOVE Catalog No.	(W) fraction	(H) fraction	(L) inch
1/2" Shanks				
T-100	T-100-V	1/16	1/2	4.500
T-101	T-101-V	5/64	1/2	4.500
T-102	T-102-V	3/32	1/2	4.500
T-103	T-103-V	1/8	1/2	4.500
11/16" Shanks				
T-104	T-104-V	3/32	11/16	5.000
T-105	T-105-V	1/8	11/16	5.000
T-106	T-106-V	5/32	11/16	5.000
T-107	T-107-V	3/16	11/16	5.000
3/4" Shanks				
T-108	T-108-V	1/8	3/4	5.000
T-109	T-109-V	5/32	3/4	5.000
T-110	T-110-V	3/16	3/4	5.000
7/8" Shanks				
T-111	T-111-V	1/8	7/8	6.000
T-112	T-112-V	5/32	7/8	6.000
T-113	T-113-V	3/16	7/8	6.000
1-1/4" Shanks				
T-116	T-116-V	3/16	1-1/8	6.000

For current pricing and availability please visit our website at www.micro100.com

FEATURING:

- All tools are ground with the required clearance angles.
- Cut-Off Tools: Carbide protrusion = 3 times thickness specified, .375" (9.5mm) maximum. Tolerance on thickness + .000" (+.00mm) - .010" (-.00mm)

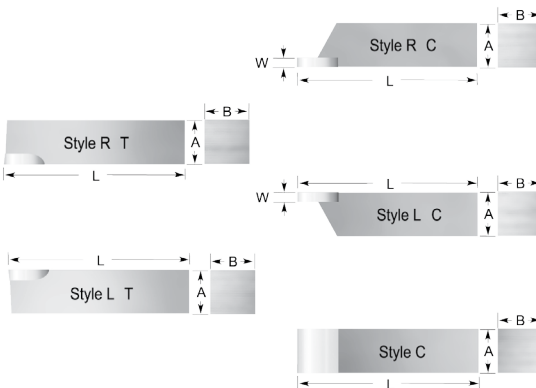

Quantity Price Breaks Available

- 1 to 11 pieces
- 12 pieces or More

TOOL		Width (W) fraction	Overall Length (L) fraction	Type
RIGHT Hand Catalog No.	LEFT Hand Catalog No.			
1/4" Shanks - A/B				
RT-250	LT-250	-	6.000	TURNING
C-250	C-250	-	6.000	FORMING
RC-250040	LC-250040	.040	6.000	CUT-OFF
RC-250060	LC-250060	.060	6.000	CUT-OFF
9/32" Shanks - A/B				
RT-281	LT-281	-	6.000	TURNING
C-281	C-281	-	6.000	FORMING
-	LC-281040	.040	6.000	CUT-OFF
RC-281060	LC-281060	.060	6.000	CUT-OFF
RC-281080	LC-281080	.080	6.000	CUT-OFF
RC-281100	LC-281100	.100	6.000	CUT-OFF
5/16" Shanks - A/B				
RT-312	LT-312	-	6.000	TURNING
C-312	C-312	-	6.000	FORMING
RC-312040	LC-312040	.040	6.000	CUT-OFF
RC-312060	LC-312060	.060	6.000	CUT-OFF
RC-312080	LC-312080	.080	6.000	CUT-OFF
RC-312100	LC-312100	.100	6.000	CUT-OFF
3/8" Shanks - A/B				
RT-375	LT-375	-	6.000	TURNING
C-375	C-375	-	6.000	FORMING
RC-375040	LC-375040	.040	6.000	CUT-OFF
RC-375060	LC-375060	.060	6.000	CUT-OFF
RC-375080	LC-375080	.080	6.000	CUT-OFF
RC-375100	LC-375100	.100	6.000	CUT-OFF
RC-375120	LC-375120	.120	6.000	CUT-OFF

TOOL		Width (W) fraction	Overall Length (L) fraction	Type
RIGHT Hand Catalog No.	LEFT Hand Catalog No.			
7/16" Shanks - A/B				
RT-437	LT-437	-	6.000	TURNING
C-437	C-437	-	6.000	FORMING
RC-437060	LC-437060	.060	6.000	CUT-OFF
-	LC-437080	.080	6.000	CUT-OFF
RC-437100	LC-437100	.100	6.000	CUT-OFF
RC-437120	LC-437120	.120	6.000	CUT-OFF
1/2" Shanks - A/B				
RT-500	LT-500	-	6.000	TURNING
C-500	C-500	-	6.000	FORMING
RC-500060	LC-500060	.060	6.000	CUT-OFF
RC-500080	LC-500080	.080	6.000	CUT-OFF
RC-500100	LC-500100	.100	6.000	CUT-OFF
RC-500120	LC-500120	.120	6.000	CUT-OFF
5/8" Shanks - A/B				
RT-625	LT-625	-	4.000	TURNING
C-625	C-625	-	4.000	FORMING
RC-625060	LC-625060	.060	4.000	CUT-OFF
RC-625080	LC-625080	.080	4.000	CUT-OFF
RC-625100	LC-625100	.100	4.000	CUT-OFF
RC-625125	LC-625125	.125	4.000	CUT-OFF
RC-625187	LC-625187	.187	4.000	CUT-OFF
3/4" Shanks - A/B				
RT-750	LT-750	-	4.000	TURNING
C-750	C-750	-	4.000	FORMING
RC-750060	LC-750060	.060	4.000	CUT-OFF
RC-750080	LC-750080	.080	4.000	CUT-OFF
RC-750100	LC-750100	.100	4.000	CUT-OFF
RC-750125	LC-750125	.125	4.000	CUT-OFF
RC-750187	LC-750187	.187	4.000	CUT-OFF

E

Style TRG

Quantity Price Breaks Available

- 1 to 5 pieces
- 6 to 11 pieces
- 12 or More

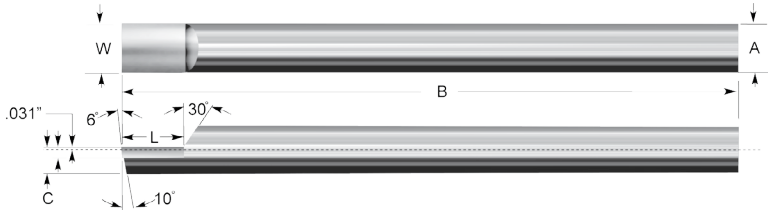
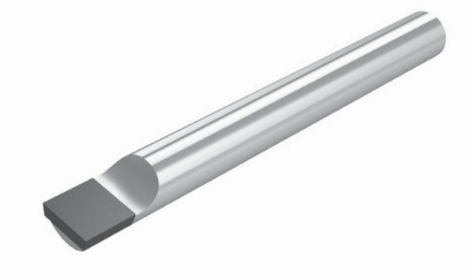

TRG Catalog No.	Overall Length (B) inch	Tip				
		(C) fraction	(T) fraction	(W) fraction	(L) fraction	
		1/4" Shanks - A	TRG-4	2.500	5/32	1/16
5/16" Shanks - A	TRG-5	3.000	3/16	3/32	5/16	3/8
3/8" Shanks - A	TRG-6	3.500	7/32	3/32	3/8	3/8
7/16" Shanks - A	TRG-7	4.000	1/4	3/32	7/16	1/2
1/2" Shanks - A	TRG-8	5.000	9/32	1/8	1/2	1/2
5/8" Shanks - A	TRG-10	6.000	11/32	5/32	5/8	5/8

For current pricing and availability please visit our website at www.micro100.com



Styles TBB / TBBL

Quantity Price Breaks Available

- 1 to 5 pieces
- 6 to 11 pieces
- 12 or More

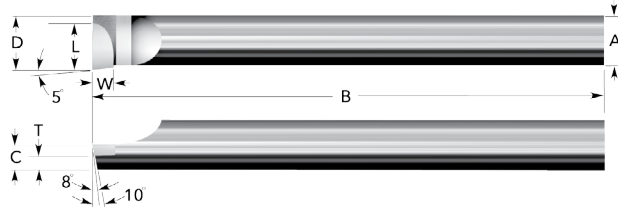

TBB	TBBL	Overall Length (B)	(C)	Minimum Bore Diameter (D)	Tip		
					(T)	(W)	(L)
RIGHT Hand Catalog No.	LEFT Hand Catalog No.	inch	fraction	fraction	fraction	fraction	fraction
1/4" Shanks - A							
TBB-250	TBBL-250	4.000	1/8	.320	1/16	3/16	1/4
5/16" Shanks - A							
TBB-312	TBBL-312	5.000	5/32	.413	1/16	1/4	5/16
3/8" Shanks - A							
TBB-375	TBBL-375	6.000	3/16	.463	1/16	1/4	5/16
1/2" Shanks - A							
TBB-500	TBBL-500	7.000	1/4	.625	1/8	1/4	1/2
5/8" Shanks - A							
TBB-625	TBBL-625	8.000	5/16	.795	1/8	1/4	5/8
3/4" Shanks - A							
TBB-750	TBBL-750	9.000	3/8	.935	1/8	1/4	5/8
1" Shanks - A							
TBB-001	TBBL-001	10.000	1/2	1.233	3/16	7/16	13/16

Bore diameters as small as .320"

TBB SET	TBBL SET	Brazed Carbide Boring Bar Sets	
RIGHT Hand Catalog No.	LEFT Hand Catalog No.	Right or Left Hand Boring Bars each set contains: five (5) Boring Bars 1/4", 3/8", 1/2", 5/8", & 3/4"	
TBB-5	TBBL-5		

For current pricing and availability please visit our website at www.micro100.com

BORING

Select a boring tool that has a bore diameter closest to, but not larger than, the desired minimum bore diameter that your application requires.

Tool overhang should not exceed 3 times (3X) the tool's shank diameter.

Rigidity of your set-up and starting the cut at centerline is of the utmost importance.

For heavy, interrupted cuts or forgings, the largest nose radius (possible) should be used.



TURNING

Rigidity of your set-up and starting the cut at centerline is of the utmost importance. A side rake angle of 15 degrees is recommended and 30-45 degrees for the tool's side cutting edge angle(s) will distribute the cutting forces and improve tool life.

For heavy, interrupted cuts or forgings, the largest nose radius (possible) should be used.

All chip breakers should have a radius that is equal to the depth at the rear.



CUT-OFF

Depending on the material, removing and breaking the chip often becomes necessary.

It is recommended to use as much feed rate as possible and utilize "interrupted" cuts or a "pecking cycle".



For more Technical Data information, please contact us at 1 (800) 421-8065

For current pricing and availability please visit our website at www.micro100.com

World Class Quality
Through Manufacturing Excellence!



Combined with Superior Strength and wear Characteristics provides *unmatched high performance productivity* at it's **BEST!**



F

Half-Round Blanks

Round Blanks

Assorted Blank Geometries

CPG Style Indexable Inserts

SPG Style Indexable Inserts

TPG Style Indexable Inserts

TD Style "Screw On" Indexable Inserts

TP Style "Screw On" Indexable Inserts



WILL NOT CHIP OR BREAK
UNDER NORMAL MACHINING CONDITIONS



F

Half-Round Blanks

Style HR
page 181



Series RT Blanks

page 185



Round Blanks

Style SR
page 182



Series STB Blanks

page 185

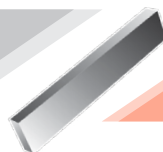

Series 1000 Blanks

page 183



Series STB-48 Blanks

page 185



Series 2000 Blanks

page 183



Indexable Inserts

Style CPG
page 186



Series 5000 Blanks

page 184



Indexable Inserts

Style SPG
page 186



Series 6000 Blanks

page 184



Indexable Inserts

Style TPG
page 186



Series 7000 Blanks

page 184



Indexable Inserts

Style TP & TD-6P
page 186



For current pricing and availability please visit our website at www.micro100.com

Style "HR" by SPECIAL
ORDER once current
inventories are depleted.

Tolerances:
D1: +.0010"/-0

Quantity Price Breaks Available

- 1 to 5 pieces
- 6 to 11 pieces
- 12 to 23 pieces
- 24 to 47 pieces
- 48 to 99 pieces
- 100 pieces or More

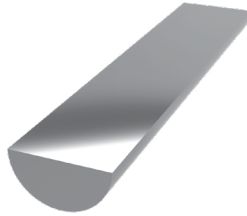

Metric sizes available.

HR Catalog No.	Split Face Dimension (D1)	Overall Length (L1)
	inch	inch
HR-125	.0625	1.500
HR-187	.0938	2.000
HR-250	.1250	2.500

F

For current pricing and availability please visit our website at www.micro100.com

Tolerances:

Shank Diameter: -.0001"-.0002"

Quantity Price Breaks Available

- 1 to 5 pieces
- 6 to 11 pieces
- 12 to 23 pieces
- 24 to 47 pieces
- 48 to 99 pieces
- 100 pieces or More

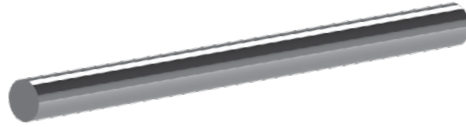

Metric sizes also available from stock.

SR Catalog No.	Overall Length (L1)
	inch
1/16" Shanks - D	
SR-062-1	1.000
SR-062-2	2.000
SR-062-3	3.000
SR-062-4	4.000
SR-062-6	6.000
SR-062-12	12.000
3/32" Shanks - D	
SR-093-1	1.000
SR-093-2	2.000
SR-093-3	3.000
SR-093-4	4.000
SR-093-6	6.000
SR-093-12	12.000
1/8" Shanks - D	
SR-125-1.5	1.500
SR-125-2	2.000
SR-125-3	3.000
SR-125-4	4.000
SR-125-6	6.000
SR-125-12	12.000
5/32" Shanks - D	
SR-156-1.5	1.500
SR-156-2	2.000
SR-156-3	3.000
SR-156-4	4.000
SR-156-6	6.000
SR-156-12	12.000
3/16" Shanks - D	
*SR-187-1.5	1.500
*SR-187-2	2.000
SR-187-4	4.000
SR-187-6	6.000
SR-187-12	12.000
1/4" Shanks - D	
*SR-250-2	2.000
*SR-250-2.5	2.500
*SR-250-3	3.000
SR-250-4	4.000
SR-250-6	6.000
SR-250-12	12.000

SR Catalog No.	Overall Length (L1)
	inch
5/16" Shanks - D	
*SR-312-2	2.000
*SR-312-2.5	2.500
*SR-312-4	4.000
SR-312-6	6.000
SR-312-12	12.000
3/8" Shanks - D	
*SR-375-2	2.000
*SR-375-2.5	2.500
*SR-375-4	4.000
SR-375-6	6.000
SR-375-12	12.000
7/16" Shanks - D	
*SR-437-2.5	2.500
SR-437-4	4.000
SR-437-6	6.000
SR-437-12	12.000
1/2" Shanks - D	
*SR-500-2.5	2.500
*SR-500-3	3.000
SR-500-4	4.000
SR-500-6	6.000
SR-500-12	6.000
9/16" Shanks - D	
*SR-562-3.5 ♦	3.500
5/8" Shanks - D	
*SR-625-3.5	3.500
SR-625-4	4.000
3/4" Shanks - D	
*SR-750-4	4.000
SR-750-6	6.000
SR-750-12	12.000
7/8" Shanks - D	
SR-875-6 ♦	6.000
1" Shanks - D	
*SR-001-4	4.000
*SR-001-5	5.000
SR-001-6	6.000
SR-001-12	12.000

♦ WHILE SUPPLIES LAST - Discontinued

* Denotes chamfered end

Series 1000 Tolerances:
T, W, L: ±.015"

Quantity Price Breaks Available

- 1 to 5 pieces
- 6 to 11 pieces
- 12 to 23 pieces
- 24 to 47 pieces
- 48 to 99 pieces
- 100 pieces or More

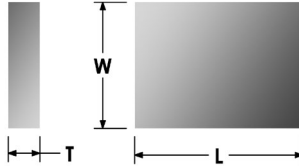

BLANK Catalog No.	T	W	L
	inch	inch	inch
Series 1000			
1025	1/16	1/4	.2500
1035	3/32	1/8	.7500
1080	3/32	5/16	.3750
1090	3/32	3/8	.3750
1105	3/32	7/16	.5000
1110	1/8	3/16	.7500
1113	1/8	3/16	.2500
1114	1/8	3/16	.3125
1140	1/8	1/4	.7500
1200	1/8	1/2	.5000
1240	5/32	5/8	.6250
1250	3/16	5/16	.4375
1270	3/16	3/8	.5000
1280	3/16	3/8	.6250
1375	1/4	1/2	.6250
1380	1/4	1/2	.7500

Quantity Price Breaks Available

- 1 to 5 pieces
- 6 to 11 pieces
- 12 to 23 pieces
- 24 to 47 pieces
- 48 to 99 pieces
- 100 pieces or More

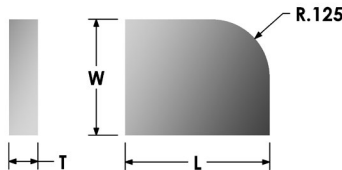

Series 2000 Tolerances:
T, W, L: ±.015"

BLANK Catalog No.	T	W	L
	inch	inch	inch
Series 2000			
2020	1/16	3/16	.2500
2030	1/16	1/4	.3125
2120	1/8	1/4	.5000
2130	1/8	1/4	.6250
2230	5/32	3/8	.7500

Quantity Price Breaks Available

- 1 to 5 pieces
- 6 to 11 pieces
- 12 to 23 pieces
- 24 to 47 pieces
- 48 to 99 pieces
- 100 pieces or More

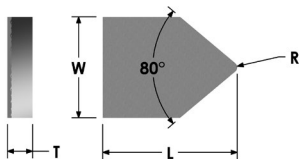

Series 5000 Tolerances:

T, W, L: $\pm 0.015''$

R: $\pm 0.010''$

BLANK Catalog No.	T	W	L	R
	inch	inch	inch	inch
Series 5000				
5030	1/16	1/4	.3125	.015
5080	3/32	5/16	.3750	.015
5100	3/32	3/8	.5000	.015
5105	3/32	7/16	.5000	.031
5200	1/8	1/2	.5000	.031
5240	5/32	5/8	.6250	.031
5410	1/4	1	.7500	.031

F

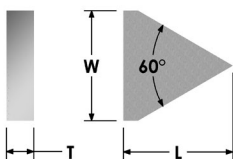

Series 6000 Tolerances:

T, W, L: $\pm 0.015''$

BLANK Catalog No.	T	W	L
	inch	inch	inch
Series 6000			
6080	3/32	5/16	.3750
6100	3/32	3/8	.5000
6200	1/8	1/2	.5000
6240	5/32	5/8	.6250
6340	3/16	3/4	.7500

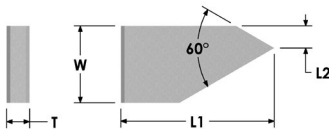

Series 7000 Tolerances:

T, W, L: $\pm 0.015''$

BLANK Catalog No.	T	W	L	L2
	inch	inch	inch	inch
Series 7000				
7060	3/32	1/4	.3750	.060
7170	1/8	5/16	.6250	.090
7230	5/32	3/8	.7500	.120

For current pricing and availability please visit our website at www.micro100.com

Quantity Price Breaks Available

- 1 to 5 pieces
- 6 to 11 pieces
- 12 to 23 pieces
- 24 to 47 pieces
- 48 to 99 pieces
- 100 pieces or More

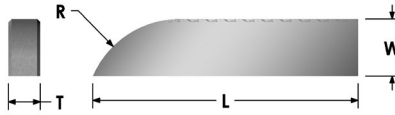

Series RT Tolerances:
T, W, L: $\pm 0.015''$
R: $\pm 0.010''$

BLANK Catalog No.	T	W	L	R
	inch	inch	inch	inch
Series RT				
RT-4	1/16	1/8	.2500	.7500
RT-6	3/32	3/16	.3125	.8750



Series STB Tolerances:
T, W, L: $\pm 0.015''$

BLANK Catalog No.	T	W	L
	inch	inch	inch
Series STB			
STB-12A	1/32	1/16	.7500
STB-13A	3/64	3/32	.8125
STB-424	1/8	3/4	6.000
STB-616	3/16	1/2	6.000
STB-616A	3/16	1/2	3.000
STB-624	3/16	3/4	6.000
STB-824	1/4	3/4	6.000

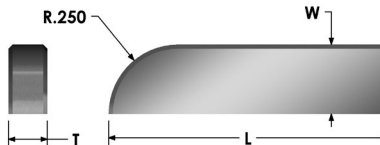

Series STB-48 Tolerances:
T, W, L: $\pm 0.015''$

BLANK Catalog No.	T	W	L
	inch	inch	inch
Series STB-48			
STB-48	1/8	1/4	1.000

For current pricing and availability please visit our website at www.micro100.com

Indexable Inserts

Positive Rake
All Surfaces Ground



Superior Rupture Strength for Exceptional Machining Versatility

Quantity Price Breaks Available

- 1 to 9 pieces
- 10-99 pieces
- 100-249 pieces
- 250-499 pieces
- 500-999 pieces

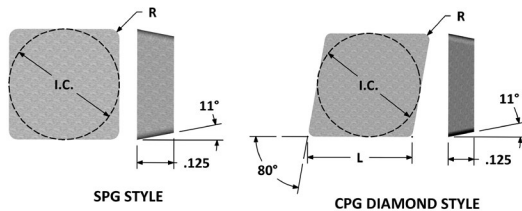

CPG / SPG Tolerances:

I.C.: ±.001"
T: ±.005"
R: ±.003"

INSERT Catalog No.	I.C.	L	R
	inch	inch	inch
CPG Style			
CPG-4621	.464	.471	.015
CPG-4622	.464	.471	.031
CPG-421	.500	.508	.015
CPG-422	.500	.508	.031
SPG Style			
SPG-322	.375	-	.031
SPG-422	.500	-	.031

F

G

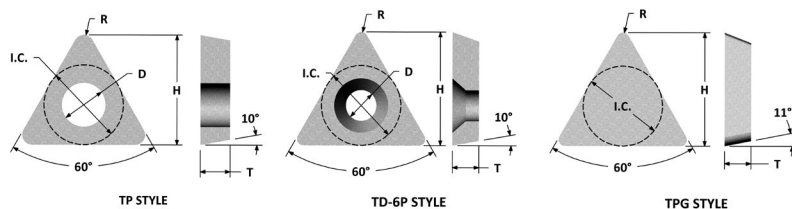

TPG / TP / TD-6P

Tolerances:
I.C.: ±.001"
T: ±.005"
R: ±.003

INSERT Catalog No.	I.C.	H	D	R	T	Set Screw Size
	inch	inch	inch	inch	inch	UN
TPG Style						
TPG-222	.250	.344		-	.125	
TPG-321	.375	.548		.015	.125	
TPG-322	.375	.532		.031	.125	
TPG-432	.500	.720		.031	.188	
TPG-433	.500	.703		.047	.188	
TP Style						
TP-41	.250	.360	.137	.015	.094	4-40
TP-42	.250	.344	.137	.031	.094	4-40
TP-61	.375	.548	.163	.015	.125	6-32
TP-62	.375	.532	.163	.031	.125	6-32
TD Style						
TP-6P-1	.375	.548	.125	.015	.125	4-40
TP-6P-2	.375	.532	.125	.031	.125	4-40

For current pricing and availability please visit our website at www.micro100.com

*Niche Indexable Tooling Focused
on BORING, TURNING, THREADING,
and MILLING...*

MICRO 100®
super carbide tools

*is very End User Friendly, Utilizing only 4 ANSI
Standard Indexable Carbide Inserts for all
Range of Applications!*



Tool Sets Available



M100 DEX™
Indexable carbide tools

Broad Range of Tools

Niche Tooling focused on Boring, Turning,
Threading, and Milling

Utilizes 4 Types of ANSI Standard Indexable Carbide Inserts

Durable and Unique Nickel Plated Tool Holders

Coolant-thru designs on Boring, Turning,
Threading, and Milling Tool Holders

Multi-layered Coated Indexable Carbide Insert

Engineered for Positive Chip Control

Superior Cost Value

Cost Effective Sets

G



**WILL NOT CHIP OR BREAK
UNDER NORMAL MACHINING CONDITIONS**



90° Turning & Facing Tools

Styles SCLCR & SCLCL

page 189



Coolant-Thru Boring Bars

90° Boring/Facing/95° Approach

Styles A0 SCLCR & A0 SCLCL

page 192

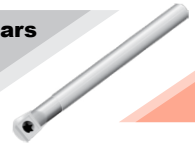

60° Turning & Facing Tools

Styles SDJCR & SDJCL

page 189

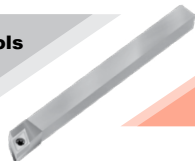

Coolant-Thru Boring Bars

Profile Boring / Facing

Styles A0 SDUCR & A0 SDUCL

page 193



75° Thru-Turning Tools

Style SCBCR

page 190

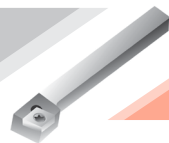

Coolant-Thru Boring Bars

Utilizing 90° Insert Face / Blind Bores

Styles A0 STFCR & A0 STFCL

page 193



75° Thru- Facing Tools

Style SCKCR

page 190

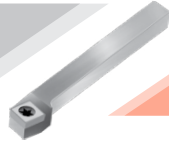

Indexable Insert Milling Tools

Style BAAP

page 194



Turning & Chamfering Tools 50°

RH / LH Style SCSCR

page 191

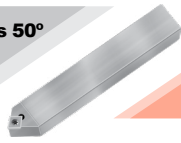

Indexable Insert Milling Tools

Style AAP - Coolant-Thru

page 194



Turning & Chamfering Tools

45° RH / 55° LH

Style SCSCR

page 191



**Indexable Tooling
Sets**

pages 195 - 197



55° Threading Tools

Style SDNCN

page 192

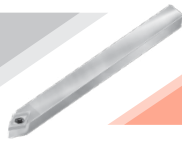

Indexable Inserts

page 198

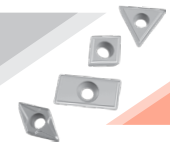

For current pricing and availability please visit our website at www.micro100.com

90° Turning & Facing Tools
with 95° Approach

Utilizes ANSI Standard
CCMT Style Inserts
(not included)

**IMPORTED
Products**

Each Tool Holder includes a High
Precision M2.5 x T-8
Torx Screw and Torx Key
(part # 16-1020)

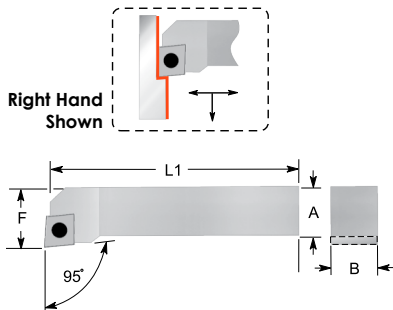

TOOL		TOOL HOLDER	"F" Dimension Over Insert (F) inch	Overall Length (L1) inch	Insert Style
RIGHT Hand Catalog No.	LEFT Hand Catalog No.	Nomenclature			
1/4" Square Shanks - A/B					
10-3231	10-3232	SCLCR/L 0404 D2	.394	2.360	CCMT 21.51
5/16" Square Shanks - A/B					
10-3233	10-3234	SCLCR/L 0505 D2	.394	2.360	CCMT 21.51
3/8" Square Shanks - A/B					
10-3235	10-3236	SCLCR/L 0606 E2	.472	2.750	CCMT 21.51
1/2" Square Shanks - A/B					
10-3237	10-3238	SCLCR/L 0808 F2	.629	3.150	CCMT 21.51
5/8" Square Shanks - A/B					
10-3241	10-3242	SCLCR/L 1010 H2	.787	3.940	CCMT 21.51
3/4" Square Shanks - A/B					
10-3251	10-3252	SCLCR/L 1212 J3	1.000	4.920	CCMT 31.51

See page 198 about Insert selections

60° Turning & Facing Tools
CNC Profile Turning

Utilizes ANSI Standard
DCMT Style Inserts
(not included)

**IMPORTED
Products**

Each Tool Holder includes a High
Precision M2.5 x T-8
Torx Screw and Torx Key
(part # 16-1020)

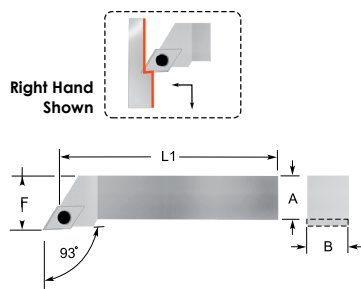

TOOL		TOOL HOLDER	"F" Dimension Over Insert (F) inch	Overall Length (L1) inch	Insert Style
RIGHT Hand Catalog No.	LEFT Hand Catalog No.	Nomenclature			
5/16" Square Shanks - A/B					
10-3641	10-3642	SDJCR/L 0505 H2	.394	3.940	DCMT 21.51
3/8" Square Shanks - A/B					
10-3651	10-3652	SDJCR/L 0606 H2	.472	3.940	DCMT 21.51
1/2" Square Shanks - A/B					
10-3653	10-3654	SDJCR/L 0808H2	.629	3.940	DCMT 21.51
5/8" Square Shanks - A/B					
10-3615	10-3616	SDJCR/L 1010 H2	.787	3.940	DCMT 21.51

See page 198 about Insert selections

75° Thru-Turning Tools Utilizing 100°
Unused
RH Cutting Corner of Insert

Utilizes ANSI Standard CCMT Style
Inserts
(not included)

Each Tool Holder includes a High
Precision M2.5 x T-8
Torx Screw and Torx Key
(part # 16-1020)

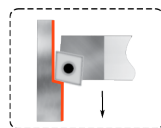

**IMPORTED
Products**

TOOL	TOOL HOLDER	"F" Dimension Over Insert (F)	Overall Length (L1)	Insert Style
Catalog No.	Nomenclature	inch	inch	
1/4" Square Shanks - A/B				
10-3151	SCBCR 0404 D2	.267	2.360	CCMT 21.51
5/16" Square Shanks - A/B				
10-3153	SCBCR 0505 D2	.267	2.360	CCMT 21.51
3/8" Square Shanks - A/B				
10-3155	SCBCR 0606 E2	.330	2.750	CCMT 21.51
1/2" Square Shanks - A/B				
10-3157	SCBCR 0808 F2	.460	3.150	CCMT 21.51
5/8" Square Shanks - A/B				
10-3159	SCBCR 1010 H2	.574	3.940	CCMT 21.51

See page 198 about Insert selections

75° Thru-Turning Tools Utilizing 100° Unused
LH Cutting Corner of Insert

Utilizes ANSI Standard CCMT Style Inserts
(not included)

Each Tool Holder includes a High Precision
M2.5 x T-8
Torx Screw and Torx Key
(part # 16-1020)

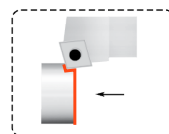

**IMPORTED
Products**

TOOL	TOOL HOLDER	"F" Dimension Over Insert (F)	Overall Length (L1)	Insert Style
Catalog No.	Nomenclature	inch	inch	
1/4" Square Shanks - A/B				
10-3211	SCKCR 0404 D2	.394	2.360	CCMT 21.51
5/16" Square Shanks - A/B				
10-3212	SCKCR 0505 D2	.394	2.360	CCMT 21.51
3/8" Square Shanks - A/B				
10-3213	SCKCR 0606 E2	.472	2.750	CCMT 21.51
1/2" Square Shanks - A/B				
10-3215	SCKCR 0808 F2	.630	3.150	CCMT 21.51
5/8" Square Shanks - A/B				
10-3217	SCKCR 1010 H2	.787	3.940	CCMT 21.51

See page 198 about Insert selections

Turning & Chamfering Tools 50° RH & LH

Utilizes ANSI Standard CCMT Style Inserts
(not included)

Each Tool Holder includes a High Precision
M2.5 x T-8
Torx Screw and Torx Key
(part # 16-1020)

IMPORTED
Products

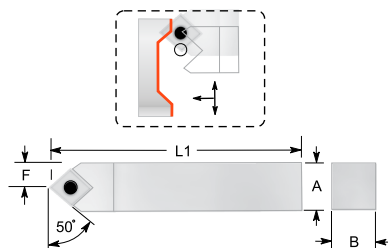
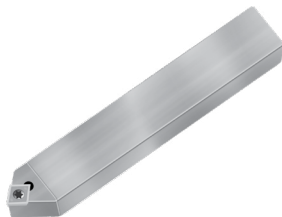

TOOL	TOOL HOLDER	"F" Dimension Over Insert (F)	Overall Length (L1)	Insert Style
Catalog No.	Nomenclature	inch	inch	
1/4" Square Shanks - A/B				
10-3311	SCMCN 0404 D2	.157	2.360	CCMT 21.51
5/16" Square Shanks - A/B				
10-3312	SCMCN 0505 D2	.157	2.360	CCMT 21.51
3/8" Square Shanks - A/B				
10-3313	SCMCN 0606 E2	.189	2.750	CCMT 21.51
1/2" Square Shanks - A/B				
10-3314	SCMCN 0808 F2	.250	3.150	CCMT 21.51
5/8" Square Shanks - A/B				
10-3315	SCMCN 1010 H2	.315	3.940	CCMT 21.51

See page 198 about Insert selections

Chamfering Tools 45° RH & 55° LH

Utilizes ANSI Standard CCMT 21.51
Inserts
(not included)

Each Tool Holder includes a High
Precision M2.5 x T-8
Torx Screw and Torx Key
(part # 16-1020)

IMPORTED
Products

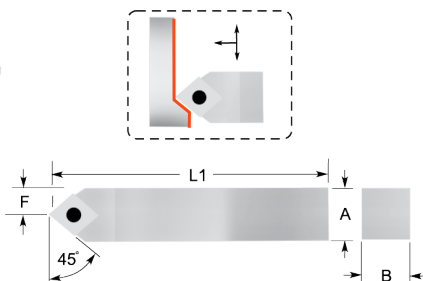
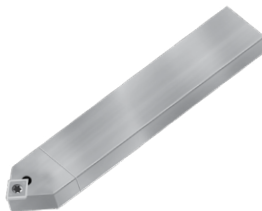

TOOL	TOOL HOLDER	"F" Dimension Over Insert (F)	Overall Length (L1)	Insert Style
Catalog No.	Nomenclature	inch	inch	
1/4" Square Shanks - A/B				
10-3351	SCSCR 0404 D2	.157	2.360	CCMT 21.51
5/16" Square Shanks - A/B				
10-3353	SCSCR 0505 D2	.157	2.360	CCMT 21.51
3/8" Square Shanks - A/B				
10-3355	SCSCR 0606 E2	.189	2.750	CCMT 21.51
1/2" Square Shanks - A/B				
10-3357	SCSCR 0808 F2	.250	3.150	CCMT 21.51
5/8" Square Shanks - A/B				
10-3359	SCSCR 1010 H2	.315	3.940	CCMT 21.51
3/4" Square Shanks - A/B				
10-3365	SCSCR 1212 J3	.390	4.920	CCMT 21.51

See page 198 about Insert selections

55° Threading Tools - 'V' Turning

Utilizes ANSI Standard DCMT Style Inserts (not included)

Each Tool Holder includes a High Precision M2.5 x T-8 Torx Screw and Torx Key (part # 16-1020)

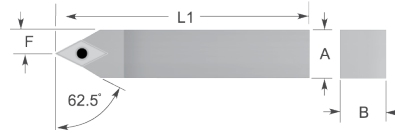
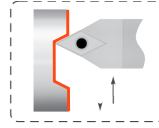

IMPORTED Products

TOOL		TOOL HOLDER	"F" Dimension Over Insert (F)	Overall Length (L1)	Insert Style
Catalog No.	Nomenclature		inch	inch	
5/16" Square Shanks - A/B					
10-3761		SDNCN 0505 H2	.157	3.940	DCMT 21.51
3/8" Square Shanks - A/B					
10-3762		SDNCN 0606 H2	.189	3.940	DCMT 21.51
1/2" Square Shanks - A/B					
10-3763		SDNCN 0808 H2	.250	3.940	DCMT 21.51
5/8" Square Shanks - A/B					
10-3764		SDNCN 1010 H2	.313	3.940	DCMT 21.51

See page 198 about Insert selections

Coolant-Thru Boring Bars 90° Boring & Facing with 95 Approach

Utilizes ANSI Standard CCMT Style Inserts not included)

Each Tool Holder includes a High Precision M2.5 x T-8 Torx Screw and Torx Key (part # 16-1020)

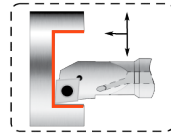

Right Hand Shown

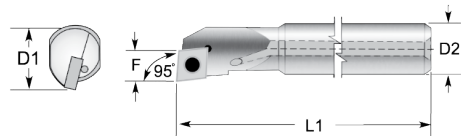

IMPORTED Products

TOOL		TOOL HOLDER	Minimum Bore Diameter (D1)	"F" Dimension Over Insert (F)	Overall Length (L1)	Insert Style
RIGHT Hand Catalog No.	LEFT Hand Catalog No.	Nomenclature				
1/4" Shanks - D2						
20-0821	20-0822	A04F SCLCR/L 2	.330	.177	3.150	CCMT 21.51
5/16" Shanks - D2						
20-0823	20-0824	A05H SCLCR/L 2	.380	.197	3.940	CCMT 21.51
3/8" Shanks - D2						
20-0825	20-0826	A06J SCLCR/L 2	.490	.275	4.330	CCMT 21.51
1/2" Shanks - D2						
20-0827	20-0828	A08K SCLCR/L 2	.630	.354	4.920	CCMT 21.51
20-0850	20-0851	A08K SCLCR/L 3	.630	.354	4.920	CCMT 31.51
5/8" Shanks - D2						
20-0829	20-0830	A010M SCLCR/L 2	.775	.433	5.900	CCMT 21.51
20-0852	20-0853	A010M SCLCR/L 3	.775	.433	5.900	CCMT 31.51
3/4" Shanks - D2						
20-0854	20-0855	A012Q SCLCR/L 3	.887	.511	7.080	CCMT 31.51

See page 198 about Insert selections

Coolant-Thru Boring Bars
Profile Boring & Facing

Utilizes ANSI Standard DCMT
Style Inserts
(not included)

Each Tool Holder includes a High
Precision M2.5 x T-8
Torx Screw and Torx Key
(part # 16-1020)

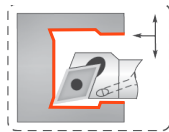

Right Hand
Shown

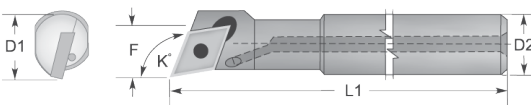

IMPORTED
Products

TOOL		TOOL HOLDER	Minimum Bore Diameter (D1) inch	"F" Dimension Over Insert (F) inch	"K" Angle (K) degree	Overall Length (L1) inch	Insert Style
RIGHT Hand Catalog No.	LEFT Hand Catalog No.	Nomenclature					
5/16" Shanks - D2							
20-0901	20-0902	A05H/L 2	.425	.197	107.5°	3.940	DCMT 21.51
3/8" Shanks - D2							
20-0931	20-0932	A06J SDUCR/L 2	.490	.275	93°	4.330	DCMT 21.51
1/2" Shanks - D2							
20-0933	20-0934	A08K SDUCR/L 2	.605	.354	93°	4.920	DCMT 21.51
5/8" Shanks - D2							
20-0935	20-0936	A010M SDUCR/L 2	.775	.433	93°	5.900	DCMT 21.51

See page 198 about Insert selections



Coolant-Thru Boring Bars
for Blind Bores Utilizing 90° Insert Face

Utilizes ANSI Standard TCMT
Style Inserts
(not included)

Each Tool Holder includes a High
Precision M2.5 x T-8
Torx Screw and Torx Key
(part # 16-1020)

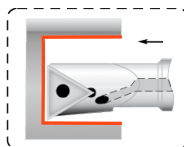

Right Hand
Shown

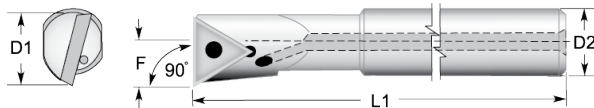

IMPORTED
Products

TOOL		TOOL HOLDER	Minimum Bore Diameter (D1) inch	"F" Dimension Over Insert (F) inch	Overall Length (L1) inch	Insert Style
RIGHT Hand Catalog No.	LEFT Hand Catalog No.	Nomenclature				
3/8" Shanks - D2						
20-1031	20-1032	A06J STFCR/L 2	.490	.275	4.330	TCMT 21.51
1/2" Shanks - D2						
20-1033	20-1034	A08K STFCR/L 2	.605	.354	4.920	TCMT 21.51
5/8" Shanks - D2						
20-1035	20-1036	A10M STFCR/L 2	.775	.433	5.900	TCMT 21.51

See page 198 about Insert selections

Indexable Insert Milling Tools

Utilizes ANSI Standard APKT Style Inserts (not included)

Each Tool Holder includes a High Precision M2.5 x T-8 Torx Screw and Torx Key (part # 16-1020)

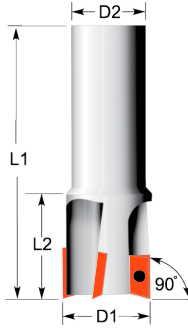

**IMPORTED
Products**

TOOL LEFT Hand Catalog No.	TOOL HOLDER Nomenclature	Cutter Diameter (D1)	Cutter Length (L2)	Number of Flutes	Overall Length (L1)	Insert Style
		inch	inch		inch	
1/2" Shanks - D2						
31-1216	BAAP 1216 2	.375	1.500	1	3.000	APKT 1003 PDR
31-1616	BAAP 1616 2	.500	1.500	1	3.000	APKT 1003 PDR
31-1816	BAAP 1816 2	.625	1.500	2	3.000	APKT 1003 PDR
3/4" Shanks - D2						
31-2424	BAAP 2424 2	.750	2.000	3	4.375	APKT 1003 PDR
31-3224	BAAP 3224 2	1.000	2.000	4	4.375	APKT 1003 PDR
31-4024	BAAP 4024 2	1.250	2.000	5	4.375	APKT 1003 PDR

See page 198 about Insert selections

G

**Coolant-Thru Indexable
Insert Milling Tools**

Utilizes ANSI Standard APKT Style Inserts (not included)

Each Tool Holder includes a High Precision M2.5 x T-8 Torx Screw and Torx Key (part # 16-1020)

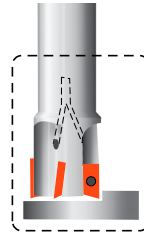
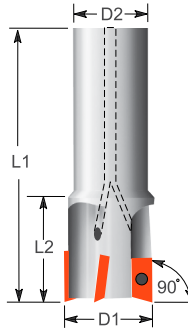

**IMPORTED
Products**

TOOL LEFT Hand Catalog No.	TOOL HOLDER Nomenclature	Cutter Diameter (D1)	Cutter Length (L2)	Number of Flutes	Overall Length (L1)	Insert Style
		inch	inch		inch	
1/2" Shanks - D2						
30-1216	AAAP 1216 2	.375	1.500	1	3.000	APKT 1003 PDR
30-1616	AAAP 1616 2	.500	1.500	1	3.000	APKT 1003 PDR
30-1816	AAAP 1816 2	.625	1.500	2	3.000	APKT 1003 PDR
3/4" Shanks - D2						
30-2424	AAAP 2424 2	.750	2.000	3	4.375	APKT 1003 PDR
30-3224	AAAP 3224 2	1.000	2.000	4	4.375	APKT 1003 PDR
30-4024	AAAP 4024 2	1.250	2.000	5	4.375	APKT 1003 PDR

See page 198 about Insert selections

M100 DEX™

Indexable carbide tools

are very user friendly...
only 4 types of ANSI Standard
Indexable Carbide Inserts required to
cover most ranges of **BORING,**
TURNING, MILLING, and
THREADING Applications!



**COST
EFFECTIVE
SETS**



**IMPORTED
Products**

Proudly offered by
MICRO 100 Tool Corporation

4 Piece SCLCR Type Coolant-Thru Boring Bar Set



SET Catalog No.	Tool Shank Diameters	Set Contents & Descriptions
40-0100	1/4 5/16 3/8 1/2	4 - SCLCR Type Boring Bars (w/Torx Screw) 4 - CCMT 21.51 Indexable Carbide Inserts 1 - Torx Key 1 - Furnished in a Hard Plastic Protective Hinged Case

G

3 Piece STFCR Type Coolant-Thru Boring Bar Set



SET Catalog No.	Tool Shank Diameters	Set Contents & Descriptions
40-2100	3/8 1/2 5/8	3 - STFCR Coolant-Thru Type Boring Bars (w/Torx Screw) 3 - TCMT 21.51 Indexable Carbide Inserts 1 - Torx Key 1 - Furnished in a Hard Plastic Protective Hinged Case

Sets include an insert for each bar featured in the set. Additional inserts available (see page 210 for selections).
For pricing and availability, contact your local Authorized Micro 100 Distributor or
contact us 1 (800) 421-8065

For current pricing and availability please visit our website at www.micro100.com



3 Piece SDUCR Type Coolant-Thru Boring Bar Set

SET Catalog No.	Tool Shank Diameters	Set Contents & Descriptions
40-2400	3/8 1/2 5/8	3 - SDUCR Coolant-Thru Type Boring Bars (w/Torx Screw) 3 - DCMT 21.51 Indexable Carbide Inserts 1 - Torx Key Furnished in a Hard Plastic Protective Hinged Case



3 Piece Coolant-Thru Milling Tool Set

SET Catalog No.	Tool Shank Diameters	Set Contents & Descriptions
40-2500	1/2 5/8 3/4	1 - #20-0850 Round 1 - #20-0852 Round 1 - #20-0854 Round (All Tools w/Insert & torx screw) 1 - Torx Key. Furnished in a Hard Plastic Protective Hinged Case

7 Piece Multi-Purpose Sets



SET Catalog No.	Tool Shank Diameters	Set Contents & Descriptions
40-7101	1/4	1 - SCLCR Square Shank 1 - SCLCL Square Shank
40-7102	5/16	1 - SCBCR Square Shank 1 - SCKCR Square Shank
40-7103	3/8	1 - SCMCN Square Shank 1 - SCSCR Square Shank (All Tools w/Torx Screw)
40-7104	1/2	7 - CCMT 21.51 Indexable Carbide Inserts 1 - Torx Key
40-7105	5/8	Furnished in a Hard Plastic Protective Hinged Case

Sets include an insert for each bar featured in the set. Additional inserts available (see page 210 for selections). For pricing and availability, contact your local Authorized Micro 100 Distributor or contact us 1 (800) 421-8065



4 Piece Coolant-Thru Boring Bar Set

SET Catalog No.	Tool Shank Diameters	Set Contents & Descriptions
40-7150	3/4	1 - #10-3251 1 - #10-3252 1 - #10-3365 1 - #20-0854 (All Tools w/Insert & torx screw) 1 - Torx Key. Furnished in a Hard Plastic Protective Hinged Case



4 Piece Multi-Purpose Sets

SET Catalog No.	Tool Shank Diameters	Set Contents & Descriptions
40-7200	5/16	1 - SDJCR Square Shank Tool
40-7201	3/8	1 - SDJCL Square Shank Tool
40-7202	1/2	1 - SDNCN Square Shank Tool 1 - SDUCR Round Shank Tool
40-7203	5/8	4 - DCMT 21.51 Indexable Carbide Inserts 1 - Torx Key Furnished in a Hard Plastic Protective Hinged Case



3 Piece Coolant-Thru Milling Tool Set

SET Catalog No.	Tool Shank Diameters	Set Contents & Descriptions
60-3003	1/2	3 - AAAP Tool Holders (Tool Holders complete with Torx Screws and APKT 1003 PDR Indexable Carbide Inserts) 1 - Torx Key Furnished in a Hard Plastic Protective Hinged Case

**IMPORTED
Products**

Proudly offered by MICRO 100 Tool Corporation

For current pricing and availability please visit our website at www.micro100.com

M100 DEX Requires ONLY 4 types of ANSI standard carbide inserts required to completely cover the entire range of products for Boring, Chamfering, Facing, Milling, Threading and Turning Applications

**IMPORTED
Products**



Styles
CCMT 21.51
CCMT 31.51



Style
DCMT 21.51



Style
TCMT 21.51



Style
APKT 1003 PDR

ANSI
Standard
Nomenclature

INSERT Type	INSERT Catalog No.	ANSI STANDARD Nomenclature	4 LAYER Coating
	50-1100 *	CCMT 21.51	TiC TiCN AL ₂ O ₃ TiN
	50-1105 *	CCMT 31.51	
	50-1200 *	DCMT 21.51	TiC TiCN AL ₂ O ₃ TiN
	50-1300 *	TCMT 21.51	TiC TiCN AL ₂ O ₃ TiN
	50-2100 *	APKT 1003 PDR	TiC TiCN AL ₂ O ₃ TiN

ACCESSORY Type	ACCESSORY Catalog No.	ACCESSORY Description
	16-1020	M2.5 x T-8 Torx Screw
	16-1030	M3.5 x T-15 Torx Screw
	16-1060	Torx Key M2.5 x TK-8
	16-1070	Torx Key M3.5 x TK-15

* Must be ordered in quantities of 10's

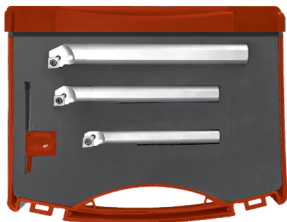

G

*World Class Quality
Through Manufacturing Excellence*

MICRO 100®
super carbide tools

*Combined with Superior Strength and
Wear Characteristics Proving Unmatched
High Performance Productivity at it's BEST!*



Miniature Boring Tools

Boring Tools

Retaining Ring Grooving Tools

Internal Threading Tools

Tool Holders

H



**WILL NOT CHIP OR BREAK
UNDER NORMAL MACHINING CONDITIONS**



Miniature Boring Tools
Style MBBM
page 201

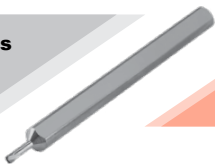

Retaining Ring Boring Tools
Style RRM
pages 204, 205



Boring Tools
Style BBM
pages 202, 203

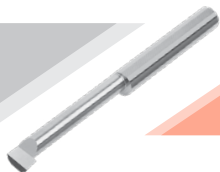

Internal Threading Tools
Style ITM
page 206

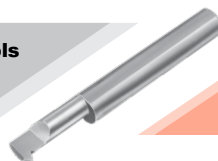

Heat Treated Tool Holders
Style THM
page 207

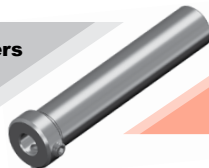

Tool Coatings... page 274



AlTiN
Aluminum
Titanium
Nitride

nACRo®
Aluminum
Chromium
Nitride
Silicone

TiN
Titanium
Nitride

ZrN
Zirconium
Nitride

MoS2
Molybdenum
Disulfide

TiCN
Titanium
Carbonitride

TiAlN
Titanium
Aluminum
Nitride

For current pricing and availability please visit our website at www.micro100.com

Page 274
for Coating
Info

Tolerances (mm):
Shank Diameter: -.0025-.0076
Minimum Bore Diameter: 0-.05
Maximum Bore Depth: +.635/-0
Overall Length: ±0.4

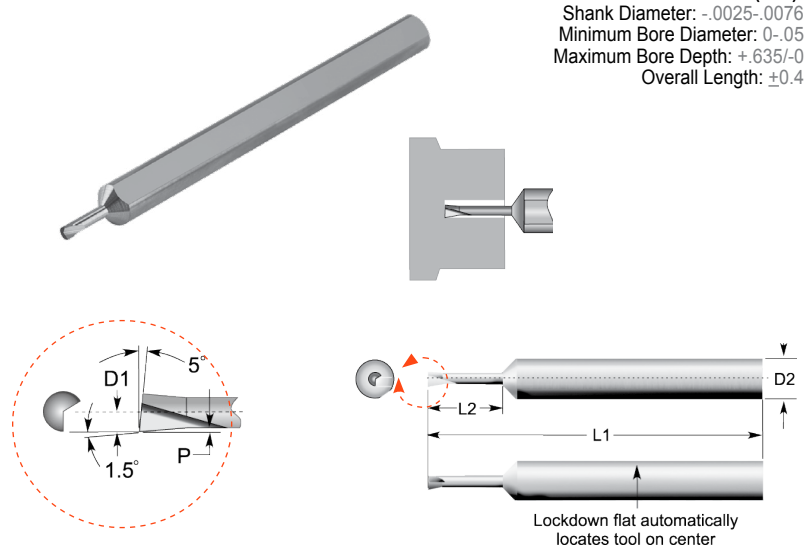

AITiN – Add “X” to the end of Catalog No.

TiN – Add “G” to the end of Catalog No.

LEFT HAND TOOLS AVAILABLE as SPECIALS

MBBM Catalog No.	Minimum Bore Diameter (T) mm	Maximum Bore Depth (W) mm	Overall Length (L) mm
3mm Shanks - D2			
MBBM-005020	0.5	2.00	38
MBBM-006025	0.6	2.50	38
MBBM-007030	0.7	3.00	38
MBBM-007040 ♦	0.7	4.00	38
MBBM-008030	0.8	3.00	38
MBBM-008040	0.8	4.00	38
MBBM-009030 ♦	0.9	3.00	38
MBBM-009040 ♦	0.9	4.00	38
MBBM-009050 ♦	0.9	5.00	38
MBBM-010030 ♦	1.0	3.00	38
MBBM-010040 ♦	1.0	4.00	38
MBBM-010050 ♦	1.0	5.00	38

♦ WHILE SUPPLIES LAST - Discontinued

For current pricing and availability please visit our website at www.micro100.com

Tolerances (mm):
Shank Diameter: -.0025-.0076
Minimum Bore Diameter: +.0-.125
Maximum Bore Depth: +1.250/-0
Overall Length: ±0.4

**Page 274
for Coating
Info**

AITiN – Add “X” to the end of Catalog No.

TiN – Add “G” to the end of Catalog No.

LEFT HAND TOOLS AVAILABLE as SPECIALS.

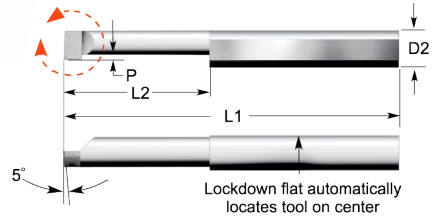
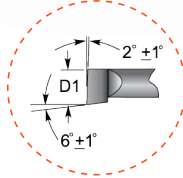
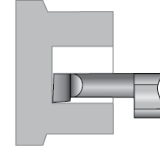

BBM Sharp Point Catalog No.	Minimum Bore Diameter (D1) mm	Maximum Bore Depth (L2) mm	Projection (P) mm	Overall Length (L1) mm
4mm Shanks - D2				
BBM-040104	1	4	0.25	50
BBM-040106	1	6	0.25	50
BBM-040108	1	8	0.25	50
BBM-040204	2	4	0.50	50
BBM-040206	2	6	0.50	50
BBM-040208	2	8	0.50	50
BBM-040210	2	10	0.50	50
BBM-040213	2	13	0.50	50
BBM-040308	3	8	0.75	50
BBM-040310	3	10	0.75	50
BBM-040313	3	13	0.75	50
BBM-040315	3	15	0.75	50
BBM-040320	3	20	0.75	50
BBM-040408	4	8	1.00	50
BBM-040410	4	10	1.00	50
BBM-040415	4	15	1.00	50
BBM-040420	4	20	1.00	50
BBM-040425	4	25	1.00	50
6mm Shanks - D2				
BBM-060510	5	10	1.25	57
BBM-060515	5	15	1.25	57
BBM-060520	5	20	1.25	57
BBM-060525	5	25	1.25	57
BBM-060528	5	28	1.25	57
BBM-060610	6	10	1.50	57
BBM-060615	6	15	1.50	57
BBM-060620	6	20	1.50	57
BBM-060625	6	25	1.50	57
BBM-060630	6	30	1.50	57
BBM-060635	6	35	1.50	57
BBM-060638	6	38	1.50	57

H

Tolerances (mm):
 Shank Diameter: -.0025-.0076
 Minimum Bore Diameter: +.0-.125
 Maximum Bore Depth: +1.250/-0
 Overall Length: ±0.4

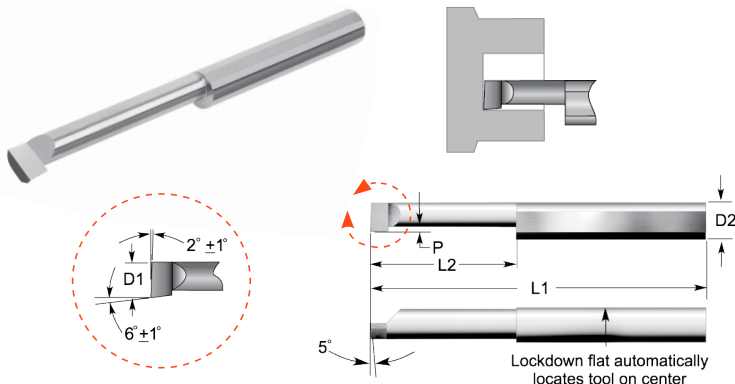

AITiN – Add “X” to the end of Catalog No.

TiN – Add “G” to the end of Catalog No.

LEFT HAND TOOLS AVAILABLE as SPECIALS.

BBM	Minimum Bore Diameter (D1)	Maximum Bore Depth (L2)	Projection (P)	Overall Length (L1)
Sharp Point Catalog No.	mm	mm	mm	mm
8mm Shanks - D2				
BBM-080715	7	15	1.75	63
BBM-080720	7	20	1.75	63
BBM-080725	7	25	1.75	63
BBM-080732	7	32	1.75	63
BBM-080738	7	38	1.75	63
BBM-080746	7	46	1.75	63
BBM-080813	8	13	2.00	63
BBM-080820	8	20	2.00	63
BBM-080825	8	25	2.00	63
BBM-080832	8	32	2.00	63
BBM-080838	8	38	2.00	63
BBM-080846	8	46	2.00	63
BBM-080850	8	50	2.00	63
10mm Shanks - D2				
BBM-100913 ♦	9	13	2.25	72
BBM-100925	9	25	2.25	72
BBM-100932	9	32	2.25	72
BBM-100938	9	38	2.25	72
BBM-100946	9	46	2.25	72
BBM-100950	9	50	2.25	72
BBM-101015	10	15	2.50	72
BBM-101020 ♦	10	20	2.50	72
BBM-101025	10	25	2.50	72
BBM-101032	10	32	2.50	72
BBM-101038	10	38	2.50	72
BBM-101050	10	50	2.50	72
12mm Shanks - D2				
BBM-121220	12	20	3.00	83
BBM-121232	12	32	3.00	83
BBM-121246	12	46	3.00	83
BBM-121260	12	60	3.00	83

♦ WHILE SUPPLIES LAST - Discontinued

Tolerances (mm):
Groove Width: +.05-0
Shank Diameter: -.0025-.0076
Minimum Bore Diameter: +0/-0.125
Maximum Bore Depth: +1.250/-0
Overall Length: ±0.4

Page 274
for Coating
Info

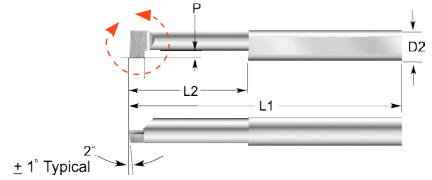
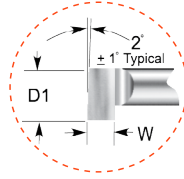
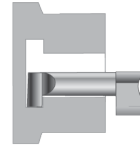
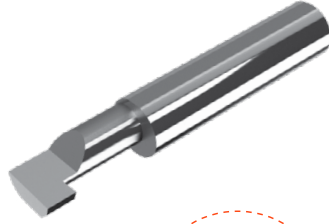

AiTIn – Add “X” to the end of Catalog No.

TiN – Add “G” to the end of Catalog No.

LEFT HAND TOOLS AVAILABLE as SPECIALS.

RRM Catalog No.	Groove Width (W)	Projection (P)	Minimum Bore Diameter (D1)	Maximum Bore Depth (L2)	Overall Length (L1)
	mm	mm	mm	mm	mm
4mm Shanks - D2					
RRM-030-10	.30	0.60	3	10	50
RRM-030-15	.30	0.60	3	15	50
RRM-040-10	.40	0.80	4	10	50
RRM-040-15	.40	0.80	4	15	50
RRM-040-20	.40	0.80	4	20	50
RRM-040-25 ♦	.40	0.80	4	25	50
6mm Shanks - D2					
RRM-050-10	.50	1.25	6	10	57
RRM-050-20	.50	1.25	6	20	57
RRM-050-25	.50	1.25	6	25	57
RRM-060-30 ♦	.60	1.25	6	30	57
RRM-070-10	.70	1.25	6	10	57
RRM-070-15 ♦	.70	1.25	6	15	57
RRM-070-20 ♦	.70	1.25	6	20	57
RRM-070-25	.70	1.25	6	25	57
RRM-080-15	.80	1.25	6	15	57
RRM-080-20	.80	1.25	6	20	57
RRM-080-25	.80	1.25	6	25	57
8mm Shanks - D2					
RRM-090-20	.90	2.50	8	20	63
RRM-090-30	.90	2.50	8	30	63
RRM-090-40 ♦	.90	2.50	8	40	63
RRM-100-10	1.00	2.50	8	10	63
RRM-100-20	1.00	2.50	8	20	63
RRM-100-30	1.00	2.50	8	30	63
RRM-100-40	1.00	2.50	8	40	63
RRM-110-10	1.10	2.50	8	10	63
RRM-110-20	1.10	2.50	8	20	63
RRM-110-40	1.10	2.50	8	40	63

♦ WHILE SUPPLIES LAST - Discontinued

Tolerances (mm):

Groove Width: +.05-0
 Shank Diameter: -.0025-.0076
 Minimum Bore Diameter: +0/-0.125
 Maximum Bore Depth: +1.250/-0
 Overall Length: ±0.4

Page 274
for Coating
Info

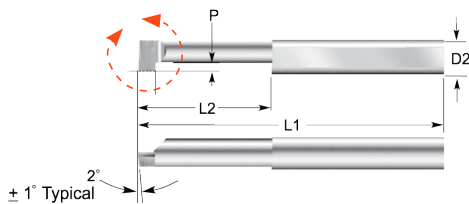
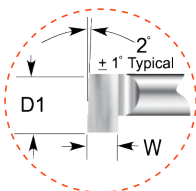
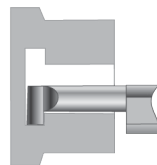
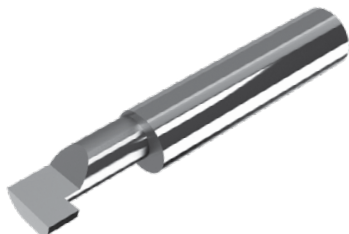

AITiN – Add “X” to the end of Catalog No.

TiN – Add “G” to the end of Catalog No.

LEFT HAND TOOLS AVAILABLE as SPECIALS.

RRM Catalog No.	Groove Width (W)	Projection (P)	Minimum Bore Diameter (D1)	Maximum Bore Depth (L2)	Overall Length (L1)
	mm	mm	mm	mm	mm
10mm Shanks - D2					
RRM-120-20	1.20	2.75	10	20	72
RRM-120-30 ♦	1.20	2.75	10	30	72
RRM-120-40 ♦	1.20	2.75	10	40	72
RRM-130-10 ♦	1.30	2.75	10	10	72
RRM-180-30 ♦	1.80	2.75	10	30	72
RRM-200-10 ♦	2.00	2.75	10	10	72
RRM-200-20	2.00	2.75	10	20	72
RRM-200-30	2.00	2.75	10	30	72
RRM-200-40 ♦	2.00	2.75	10	40	72
12mm Shanks - D2					
RRM-300-20	3.00	3.75	12	20	83
RRM-300-30	3.00	3.75	12	30	83
RRM-300-40	3.00	3.75	12	40	83
RRM-400-50 ♦	4.00	3.75	12	50	83
RRM-500-30	5.00	3.75	12	30	83
RRM-500-40	5.00	3.75	12	40	83
RRM-500-50	5.00	3.75	12	50	83
RRM-600-40 ♦	6.00	3.75	12	40	83
RRM-600-50	6.00	3.75	12	50	83

♦ WHILE SUPPLIES LAST - Discontinued

For current pricing and availability please visit our website at www.micro100.com

Tolerances (mm):
Shank Diameter: -.0025-.0076
Minimum Bore Diameter: +.0-.127
Maximum Bore Depth: +1.270/-0
Overall Length: ±.38

Page 274
for Coating
Info

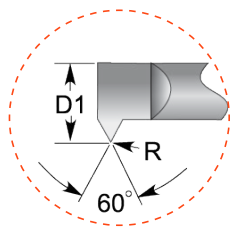
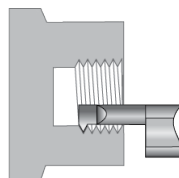

Tool Radius:
.05mm (±.03mm)

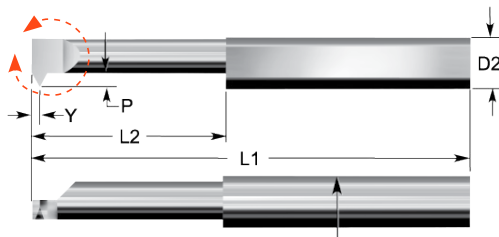

Lockdown flat automatically
locates tool on center

AITiN – Add “X” to the end of
Catalog No.

TiN – Add “G” to the end of
Catalog No.

LEFT HAND TOOLS AVAILABLE as SPECIALS.

ITM Catalog No.	Metric Threads	Minimum Bore Diameter (D1)	Projection	Maximum Bore Depth (L2)	Offset Point	Overall Length
	* (Pitch) mm	mm	(P) mm	mm	(Y) mm	(L1) mm
6mm Shanks - D2						
ITM-064613	.7 – 1.5	4.60	1.22	13	.71	57
ITM-064625	.7 – 1.5	4.60	1.22	25	.71	57
ITM-065115	1.25 – 1.75	5.10	1.32	15	.76	57
ITM-065128	1.25 – 1.75	5.10	1.32	28	.76	57
8mm Shanks - D2						
ITM-085815	1.25 – 2.0	5.80	1.50	15	.86	63
ITM-085825	1.25 – 2.0	5.80	1.50	25	.86	63
ITM-085838	1.25 – 2.0	5.80	1.50	38	.86	63
ITM-087420	.75 – 2.25	7.40	1.91	20	1.09	63
ITM-087432	.75 – 2.25	7.40	1.91	32	1.09	63
ITM-087446	.75 – 2.25	7.40	1.91	46	1.09	63
10mm Shanks - D2						
ITM-109620 ♦	1.75 – 3.0	9.60	2.41	20	1.40	72
ITM-109632 ♦	1.75 – 3.0	9.60	2.41	32	1.40	72
ITM-109646 ♦	1.75 – 3.0	9.60	2.41	46	1.40	72
12mm Shanks - D2						
ITM-121120 ♦	2.0 – 4.0	11.40	3.23	20	1.85	83
ITM-121132 ♦	2.0 – 4.0	11.40	3.23	32	1.85	83
ITM-121150 ♦	2.0 – 4.0	11.40	3.23	50	1.85	83

♦ WHILE SUPPLIES LAST - Discontinued

*Thread ranges are based on height of sharp thread (.866P) and Projection.



FEATURING:

- Precision Ground Heat Treated Steel Shanks
- 2 lockdown screws 90° apart

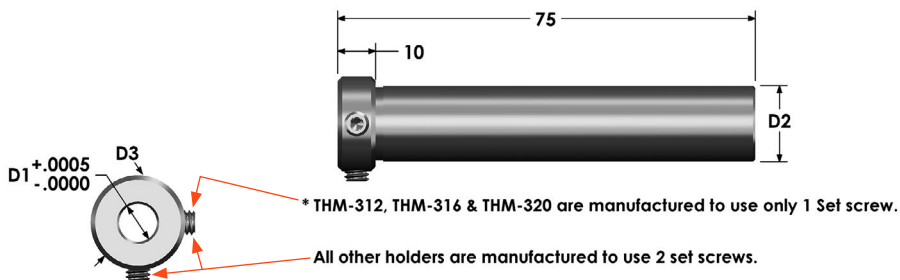

THM Catalog No.	Bore Diameter (D1)	Collar Diameter (D3)
	mm	mm
12mm Shanks - D2		
THM-312	3	15
THM-412	4	15
THM-612	6	15
THM-812	8	15
16mm Shanks - D2		
THM-316	3	19
THM-416	4	19
THM-616	6	19
THM-816	8	19
THM-1016	10	19
THM-1216	12	19
20mm Shanks - D2		
THM-320	3	25
THM-420	4	25
THM-620	6	25
THM-820	8	25
THM-1020	10	25
THM-1220	12	25

For current pricing and availability please visit our website at www.micro100.com

**World Class Quality
Carbide Tooling Through
Manufacturing Excellence!**

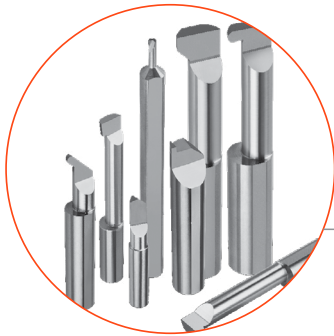
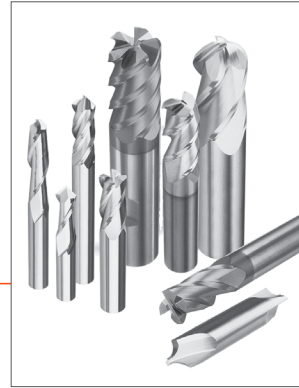

**Proprietary Micro-Grain
carbide with highest
transverse rupture strength.**

**Unmatched in toughness and application versatility. Superior in
material removal and tool life.**

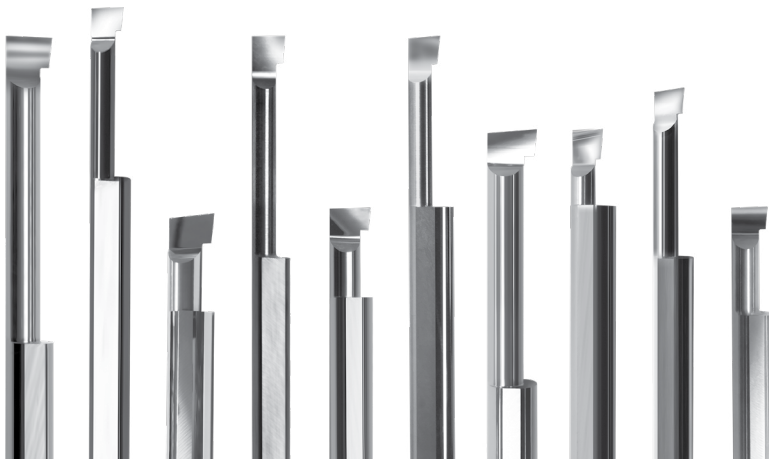

*World Class Quality
Through Manufacturing Excellence*

MICRO 100®
super carbide tools

*Combined with Superior Strength and
Wear Characteristics Providing Unmatched
High Performance Productivity at it's BEST!*



Thread Mills

Single Flute Routers

Engraving Tools

Full Radius Tools

Combined Drill and Countersink Tools



**WILL NOT CHIP OR BREAK
UNDER NORMAL MACHINING CONDITIONS**



Thread Mills

Style TMM
page 211

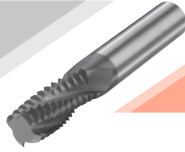

Engraving Tools

Styles RTCM / RSCM / RNCM
pages 215 - 217



Single Flute Routers

Right / Left Hand Spiral, Right Hand Cut
Styles SFPM / SFLM
pages 212, 213

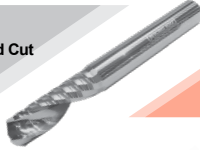

Full Radius Tools

Style RSFM
page 218

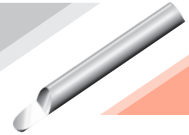

Single Flute Routers

for Aluminum Style SFAM
page 214



Combined Drill & Countersinks

Style DCM
page 219

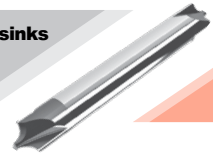

MICRO 100®
super carbide tools

World Class Quality
Carbide Tooling Through
Manufacturing Excellence!

For current pricing and availability please visit our website at www.micro100.com

FEATURING:

- Helical flute design for reducing cutting forces, smoother cuts, longest tool life, and maximum thread milling performances.
- 100% thread form, superior threads vs. tapping.
- Cuts right hand and left hand high quality threads.
- Suitable for all types of materials, especially heat treated and difficult to machine workpiece metals.
- Uncoated thread mills are also available from stock.

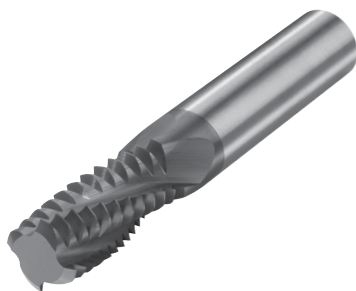

Tolerances (mm):
 Cutter Diameter: h8
 Shank Diameter: -.0025-.0076
 Length of Cut: +1.3-.0
 T.I.R. MAX: .013
 Overall Length: ±0.38

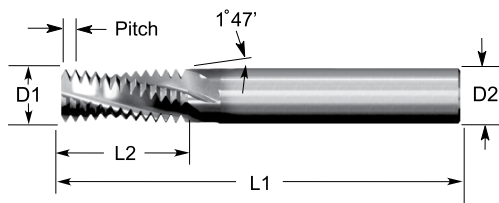

End Mills Coated with:

AlTiN

TMM Catalog No.	Minimum Thread Size	Pitch	Cutter Diameter (D1)	Number of Flutes	Length of Cut (T.P.I.)	Overall Length (L1)
	mm	mm	mm		mm	mm
6mm Shanks - D2						
TMM-045075X	M4.5	0.75	3.00	3	6	57
TMM-050080X	M5.0	0.80	3.00	3	8	57
TMM-060100X	M6.0	1.00	4.30	3	12	57
TMM-080075X	M8.0	0.75	6.00	3	16	57
TMM-080125X	M8.0	1.25	6.00	3	16	57
8mm Shanks - D2						
TMM-100150X	M10.0	1.50	7.62	4	20	75
10mm Shanks - D2						
TMM-120100X	M12.0	1.00	9.15	4	22	100
TMM-120175X	M12.0	1.75	9.15	4	22	100
TMM-140150X ♦	M14.0	1.50	9.40	4	22	100
12mm Shanks - D2						
TMM-180150X	M18.0	1.50	11.94	4	32	100
TMM-200250X	M20.0	2.50	11.94	4	32	100
16mm Shanks - D2						
TMM-240300X ♦	M24.0	3.00	15.75	4	35	100

♦ WHILE SUPPLIES LAST - Discontinued

For programming and technical assistance, go to www.micro100.com to download our "Thread Mill Auto Assist" program or call us to obtain your free disk.

FEATURING:

- High speed, solid carbide routers for plastic and composite materials.
- Optimized rake and clearance angles produce highest material removal rates and improved surface finishes.
- Innovative "O" flute design avoids chip melting and chip re-welding problems and evacuates chips efficiently.
- Open flute design with polished, mirror-like flute finish.
- Left-hand spiral routers are ideal for driving chips downward and when cutting forces on multi-layer workpieces require a down-cut operation.

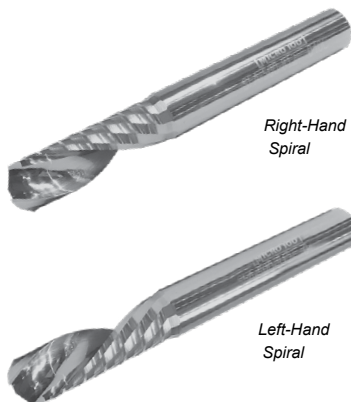

Tolerances (mm):
Cutter Diameter: +.000-.05
Shank Diameter: -.0025-.0076
T.I.R. MAX: .013
Overall Length: ±0.4

**HIGH PERFORMANCE
SINGLE FLUTE
ROUTERS**

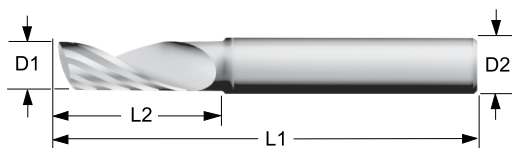

SFPM Catalog No.	SFLM Catalog No.	Cutter Diameter (D1) mm	Flute Length (L2) mm	Overall Length (L1) mm
3mm Shanks - D2				
SFPM-010-10	SFLM-010-10	1	5	57
SFPM-020-10	SFLM-020-10	2	6	57
SFPM-020-20	SFLM-020-20	2	10	38
SFPM-020-30	SFLM-020-30 ♦	2	12	57
SFPM-020-40	SFLM-020-40 ♦	2	14	75
SFPM-030-10	SFLM-030-10	3	8	57
SFPM-030-20	SFLM-030-20	3	12	38
4mm Shanks - D2				
SFPM-040-10	SFLM-040-10	4	12	57
SFPM-040-20	SFLM-040-20	4	15	40
5mm Shanks - D2				
SFPM-050-10	SFLM-050-10 ♦	5	16	50
6mm Shanks - D2				
SFPM-030-50	SFPM-030-50 ♦	3	8	57
SFPM-030-60	SFPM-030-60 ♦	3	18	57
SFPM-030-70	SFPM-030-70 ♦	3	18	75
SFPM-040-50	SFLM-040-50	4	12	57
SFPM-040-60	SFLM-040-60	4	20	57
SFPM-040-70	SFLM-040-70 ♦	4	20	75
SFPM-050-40	SFLM-050-40	5	16	50
SFPM-050-50	SFLM-050-50 ♦	5	28	60
SFPM-050-60	SFLM-050-60 ♦	5	28	75
SFPM-060-10	SFLM-060-10	6	16	50
SFPM-060-20	SFLM-060-20	6	28	60
SFPM-060-30	SFLM-060-30 ♦	6	28	75

♦ WHILE SUPPLIES LAST - Discontinued

FEATURING:

- High speed, solid carbide routers for plastic and composite materials.
- Optimized rake and clearance angles produce highest material removal rates and improved surface finishes.
- Innovative "O" flute design avoids chip melting and chip re-welding problems and evacuates chips efficiently.
- Open flute design with polished, mirror-like flute finish.
- Left-hand spiral routers are ideal for driving chips downward and when cutting forces on multi-layer workpieces require a down-cut operation.



Tolerances (mm):
Cutter Diameter: +.000-.005
Shank Diameter: -.0025-.0076
T.I.R. MAX: .013
Overall Length: ±0.4

**HIGH PERFORMANCE
SINGLE FLUTE
ROUTERS**

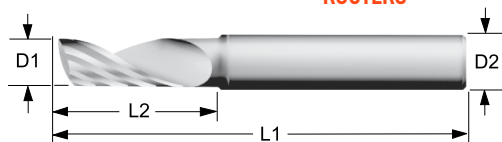

SFPM Catalog No.	SFLM Catalog No.	Cutter Diameter (D1) mm	Flute Length (L2) mm	Overall Length (L1) mm
8mm Shanks - D2				
SFPM-040-80	SFLM-040-80	4	20	95
SFPM-050-70	SFLM-050-70	5	20	95
SFPM-060-50	SFLM-060-50 ♦	6	35	75
SFPM-060-60	SFLM-060-60	6	20	95
SFPM-080-10	–	8	18	50
SFPM-080-20	SFLM-080-20 ♦	8	22	63
SFPM-080-30	–	8	30	75
SFPM-080-40	SFLM-080-40 ♦	8	40	100
10mm Shanks - D2				
SFPM-100-10	SFLM-100-10	10	25	72
SFPM-100-20	SFLM-100-20 ♦	10	55	100
SFPM-100-30	SFLM-100-30 ♦	10	30	150
12mm Shanks - D2				
SFPM-120-10	SFLM-120-10 ♦	12	30	83
SFPM-120-20	–	12	40	150
16mm Shanks - D2				
SFPM-160-20 ♦	–	16	50	150
20mm Shanks - D2				
SFPM-200-20 ♦	SFLM-200-20 ♦	20	50	150

♦ WHILE SUPPLIES LAST - Discontinued

For current pricing and availability please visit our website at www.micro100.com

SFAM

Single Flute Router for Aluminum
Right Hand Spiral, Right Hand
Cut - Metric



FEATURING:

- High speed, solid carbide routers for aluminum and non-ferrous cutting applications.
- Optimized rake and clearance angles produce highest material removal rates and improved surface finishes.
- Innovative single flute end mill geometry avoids chip melting and chip re-welding problems.
- Unique open flute design with polished, mirror-like flute finish.



Tolerances (mm):
 Cutter Diameter: +.00-.05
 Shank Diameter: -.0025-.0076
 T.I.R. MAX: .013
 Overall Length: ±0.8

**HIGH PERFORMANCE
SINGLE FLUTE
ROUTERS**

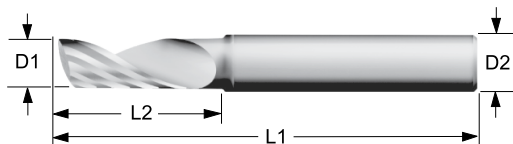

SFAM Catalog No.	Cutter Diameter (D1)	Flute Length (L2)	Overall Length (L1)
	mm	mm	mm
6mm Shanks - D2			
SFAM-020020	2	6	57
SFAM-030020	3	12	57
SFAM-040020	4	16	57
SFAM-050025	5	20	57
SFAM-060030	6	25	57
SFAM-060100	6	20	100
8mm Shanks - D2			
SFAM-080040	8	30	75
SFAM-080100	8	20	100
10mm Shanks - D2			
SFAM-100050	10	35	90
SFAM-100100	10	25	120
12mm Shanks - D2			
SFAM-120050	12	40	90
SFAM-120100	12	25	120
16mm Shanks - D2			
SFAM-160100	16	30	150

For current pricing and availability please visit our website at www.micro100.com

Tolerances (mm):
Shank Diameter:
-.0025-.0076
Split Tolerance
+.025-.000
of tool center
Offset Point: ±.025
Overall Length: ±.38

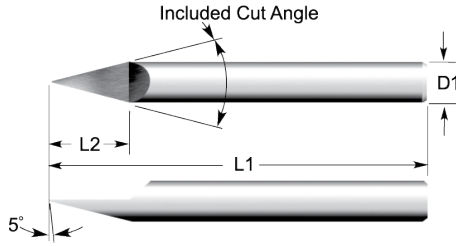
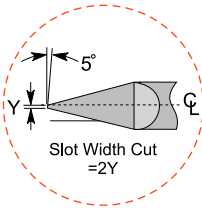

**Relieved for
Right-Hand cut**

AITiN – Add “X” to the end of Catalog No.

RTCM		Included Cut Angle (A)	Split Length (L2)	Offset Point (Y)	Overall Length (L1)
Single End Catalog No.	Double End Catalog No.				
		degree	mm	mm	mm
3mm Shanks - D1					
RTCM-030-1	RTCM-030-2	30°	5	0.10	38
4mm Shanks - D1					
RTCM-040-1	RTCM-040-2	30°	6	0.10	50
5mm Shanks - D1					
RTCM-050-1 ♦	RTCM-050-2 ♦	30°	7	0.10	50
6mm Shanks - D1					
RTCM-060-1	RTCM-060-2	30°	8	0.10	57
8mm Shanks - D1					
RTCM-080-1	RTCM-080-2	30°	10	0.10	63
10mm Shanks - D1					
RTCM-100-1 ♦	RTCM-100-2 ♦	30°	12	0.10	72

♦ WHILE SUPPLIES LAST - Discontinued

For current pricing and availability please visit our website at www.micro100.com

Tolerances (mm):
Shank Diameter: .0025-.0076
Split Tolerance: .025-.000 of tool center
Offset Point: ±.025
Overall Length: .38

**Page 274
for Coating
Info**

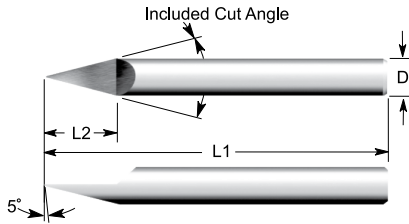
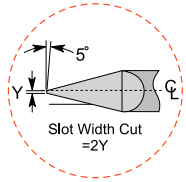
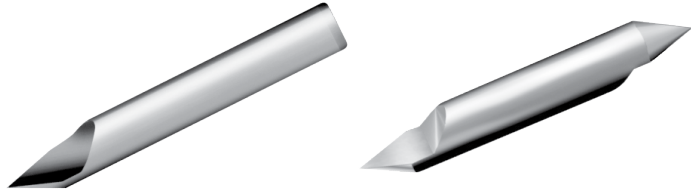

RSCM- Single End

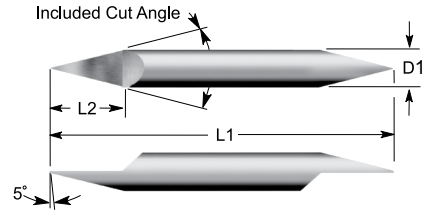

RSCM- Double End

**Relieved for
Right-Hand cut**

AITiN – Add “X” to the end of Catalog No.

RSCM		Included Cut Angle (A)	Split Length (L2)	Offset Point (Y)	Overall Length (L1)
Single End Catalog No.	Double End Catalog No.				
		degree	mm	mm	mm
2mm Shanks - D1					
-	RSCM-020-2 ♦	60°	4	0.10	38
3mm Shanks - D1					
RSCM-030-1	RSCM-030-2	60°	5	0.10	38
4mm Shanks - D1					
RSCM-040-1	RSCM-040-2	60°	6	0.10	50
5mm Shanks - D1					
RSCM-050-1 ♦	RSCM-050-2	60°	7	0.10	50
6mm Shanks - D1					
RSCM-060-1	RSCM-060-2	60°	8	0.10	57
8mm Shanks - D1					
RSCM-080-1	RSCM-080-2 ♦	60°	10	0.10	63
10mm Shanks - D1					
RSCM-100-1 ♦	RSCM-100-2	60°	12	0.10	72
12mm Shanks - D1					
RSCM-120-1	RSCM-120-2	60°	14	0.10	83

♦ WHILE SUPPLIES LAST - Discontinued

For current pricing and availability please visit our website at www.micro100.com

Page 274
for Coating
Info

Tolerances (mm):
Shank Diameter: .0025-.0076
Split Tolerance:
.025-.000 of tool center
Offset Point: ±.025
Overall Length: .38

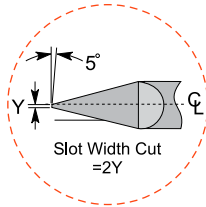
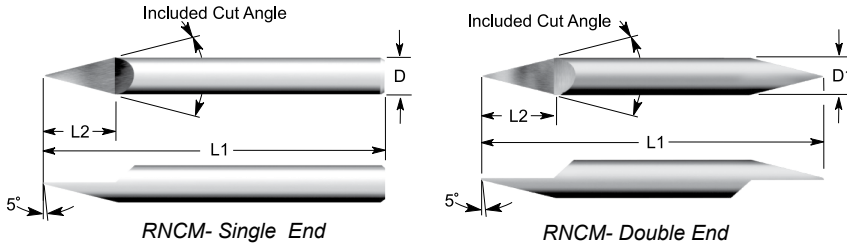
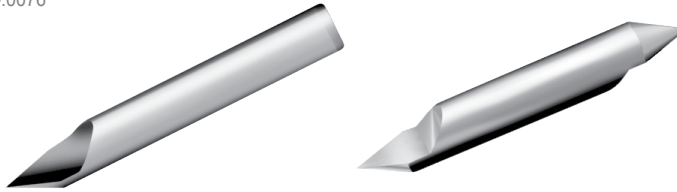

Relieved for
Right-Hand cut

AITin – Add “X” to the end of Catalog No.

RNCM		Included Cut Angle (A)	Split Length (L2)	Offset Point (Y)	Overall Length (L1)
Single End Catalog No.	Double End Catalog No.				
		degree	mm	mm	mm
2mm Shanks - D1					
-	RNCM-020-2 ♦	90°	4	0.10	38
3mm Shanks - D1					
RNCM-030-1	RNCM-030-2	90°	5	0.10	38
4mm Shanks - D1					
RNCM-040-1	RNCM-040-2	90°	6	0.10	50
5mm Shanks - D1					
RNCM-050-1 ♦	RNCM-050-2	90°	7	0.10	50
6mm Shanks - D1					
RNCM-060-1	RNCM-060-2	90°	8	0.10	57
8mm Shanks - D1					
RNCM-080-1 ♦	RNCM-080-2 ♦	90°	10	0.10	63
10mm Shanks - D1					
RNCM-100-1 ♦	-	90°	12	0.10	72
12mm Shanks - D1					
RNCM-120-1 ♦	RNCM-120-2 ♦	90°	14	0.10	83

♦ WHILE SUPPLIES LAST - Discontinued

For current pricing and availability please visit our website at www.micro100.com

RSFM

Single and Double Split End,
Right Hand
Full Radius Tools



Tolerances:

Overall Length: $\pm .38\text{mm}$

Shank Diameter: $-.0025\text{mm}$ to $-.0076\text{mm}$

Split Length in proportion to length of tool.

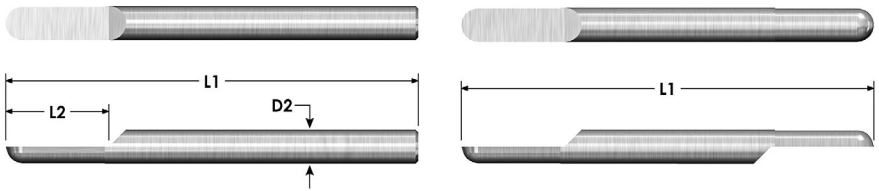
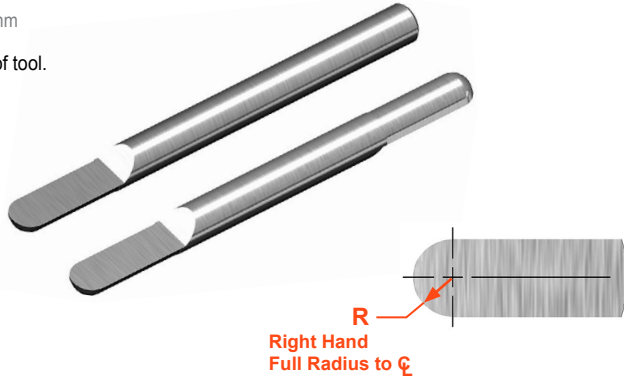

RSFM	RSFM	Split Length (L2)	Overall Length (L1)
SINGLE ENDED Catalog No.	DOUBLE ENDED Catalog No.		
2mm Shanks – D2		metric	metric
RSFM-020-1 ♦	RSFM-020-2 ♦	4	38
3mm Shanks – D2			
RSFM-030-1 ♦	RSFM-030-2 ♦	5	38
4mm Shanks – D2			
RSFM-040-1 ♦	RSFM-040-2 ♦	6	50
5mm Shanks – D2			
RSFM-050-1 ♦	RSFM-050-2 ♦	7	50
6mm Shanks – D2			
RSFM-060-1 ♦	RSFM-060-2 ♦	8	57
8mm Shanks – D2			
RSFM-080-1 ♦	RSFM-080-2 ♦	10	63
10mm Shanks – D2			
RSFM-100-1 ♦	RSFM-100-2 ♦	12	72
12mm Shanks – D2			
RSFM-120-1 ♦	RSFM-120-2 ♦	14	83

♦ WHILE SUPPLIES LAST - Discontinued

For current pricing and availability please visit our website at www.micro100.com

Tolerances (mm):
Pilot Diameter: +.08/-0
Pilot Length: +.76/-0
Shank Diameter:
-.0025 to -.0076

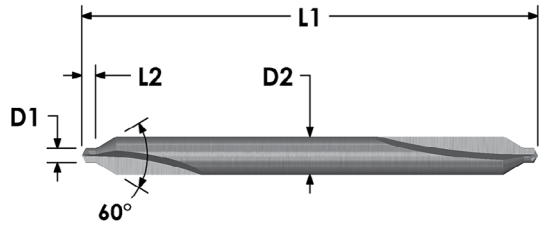
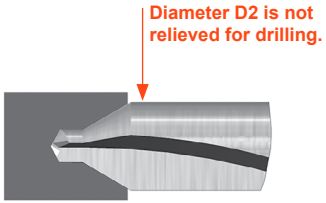
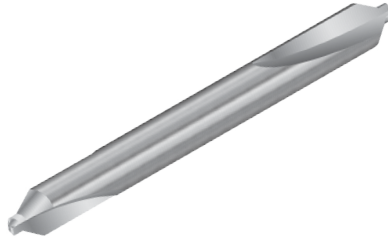

DCM Catalog No.	Pilot Diameter (D1) mm	Pilot Length (L2) mm	Overall Length (L1) mm
3.15mm Shanks - D2			
DCM-005	0.50	0.8	35.0
DCM-008	0.80	1.1	35.0
DCM-010	1.00	1.3	35.0
DCM-013	1.25	1.6	35.0
4mm Shanks - D2			
DCM-016	1.60	2.0	35.5
6.3mm Shanks - D2			
DCM-025	2.50	3.1	45.0
8mm Shanks - D2			
DCM-032	3.15	3.9	50.0

For current pricing and availability please visit our website at www.micro100.com

SPECIAL TOOLING

50 years of unrivaled manufacturing quality.

CUSTOM TOOLS MANUFACTURED FOR YOU

MICRO 100 has built a reputation for manufacturing high-quality tooling. Your custom tools are given the same care and attention to detail that we give while making our standard tools. Talk to your sales representative or give customer service a call to discuss your custom tooling needs.

Customer Service
Toll Free: (800) 421 - 8065

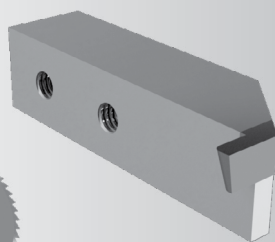
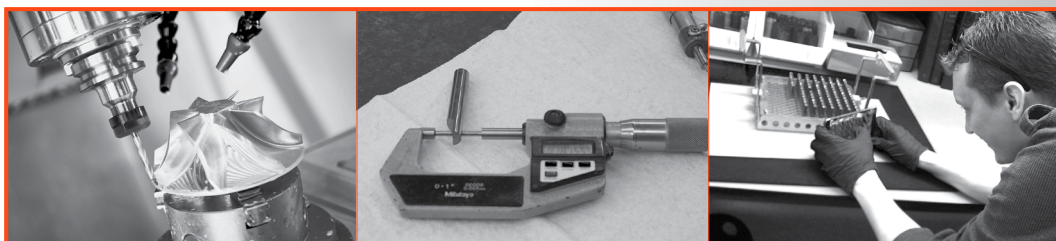

For current pricing and availability please visit our website at www.micro100.com

*Proprietary Micro Grain Carbide
with the Highest Transverse Rupture Strength...*

MICRO 100®
super carbide tools

*are Unmatched in Toughness and Application Versatility
with Superior Material Removal and Tool Life.*



Hard Milling Miniature End Mills

Miniature End Mills

2, 3, 4, 5, 6 Flute End Mills

End Mills for Hard Milling Applications

Stub Length End Mills

the "SHREDDER"

the "V-HEMOTH"

Long Length End Mills

Mold Making End Mills

Corner Rounding End Mills

Tapered End Mills

Drill Mills

Ball Nose End Mills

Spherical Ball Nose End Mills



**WILL NOT CHIP OR BREAK
UNDER NORMAL MACHINING CONDITIONS**



Miniature Hard Milling End Mills
Style MEFM
pages 224 - 228



Hard Milling End Mills
Styles HMCM, HMRM, HMSM, & HMUM
pages 240, 241, 245

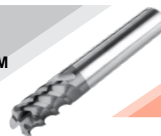

Miniature End Mills
Styles MMRM, AMRM, RMEM
pages 229-230, 232, 233



the "SHREDDER"
Styles SALM, SARM, SHLM & SHRM
pages 244, 247



2/3/4 Flute End Mills
Styles AECM, AEMM, EMSM & GEMM
pages 234 - 237

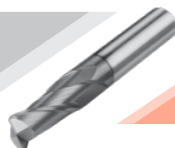

the "V-HEMOTH" 4 FLUTES
Styles VHSM, VHMM & VLRM
pages 246, 248, 250



2/3/4 Flute End Mills
Styles ARMM & ASMM
pages 238, 239



the "V-HEMOTH" 5 FLUTES
Styles VHSM, VHMM
pages 246, 249

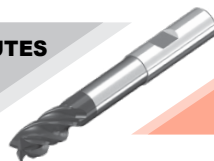

4 & 6 Flute End Mills
Style EMHM
page 243

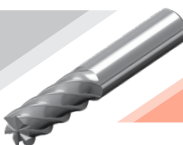

Long Length End Mills
Styles ALMM, AELM, GELM, GLRM
pages 251, 252, 255, 259



3 & 4 Flute End Mills
Style SDHM
page 242



Corner Rounding End Mills
Style CREM
page 253



Drill Mills
Style DMM
page 254

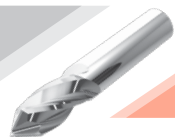

Miniature Ball Nose End Mills
2 FLUTE
Styles BEFM for Hard Milling
pages 256, 257



For current pricing and availability please visit our website at www.micro100.com

Miniature Ball Nose End Mills
Styles BMRM & BMSM
page 231



2/3/4 Flute Ball Nose End Mills
Style BEMM
page 263



Miniature End Mills
Mold Making and Shrink Fit
Styles SFBM & MMBM
pages 258, 260, 261



Spherical Ball Nose End Mills
Style SBMM
page 264



the "V-HEMOTH" Ball Nose End Mills
Style VHBM
page 262



2 & 4 Flute Ball Nose End Mills
Style HMBM
page 265



Long Length Ball Nose End Mills
Styles BELM & BLRM
pages 266, 267



Superior rupture strength for exceptional machining versatility..

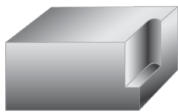

Side Milling



Open End Slot Milling



Plunging



Open End Slot Milling



Closed End Slot Milling

For current pricing and availability please visit our website at www.micro100.com

MEFM

2 Flute, Extra Fine Carbide,
Hard Milling, Miniature End Mills -
Metric



FEATURING:

- These precision miniature end mills are ideal for finishing, and semi-finishing cuts and universal milling applications in soft, medium, and hard materials.
- Machine Hardened Materials 45-68 Rc
- Extra Fine Carbide End Mills Engineered for Hard Milling Applications.

Tolerances (mm):
Shank Diameter: -.0025-.0076
Cutter Diameter: +.0000-.0127
T.I.R. MAX: .0127

Longer necks are reduced neck

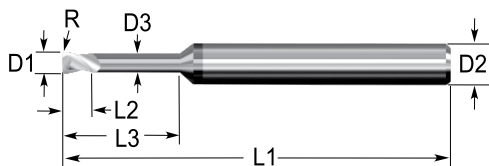
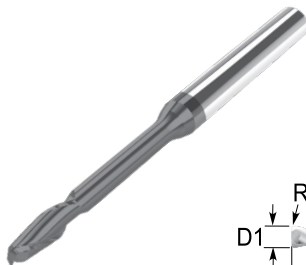

End Mills Coated with
nACRO[®]
(Nanotech "CR")

MEFM		Cutter Diameter (D1)	Flute Length (L2)	Overall Reach (L3)	Neck Diameter (D3)	Corner Radius (R)	Overall Length (L1)
2 FLUTE Catalog No.							
Uncoated	Coated	mm	mm	mm	mm	mm	mm
3mm Shanks - D2							
MEFM-001-015	MEFM-001-015K ♦	0.1	0.15	0.15	N/A	0.00	38
MEFM-015-025	MEFM-015-025K	0.15	0.25	0.25	N/A	0.00	38
MEFM-002-030	MEFM-002-030K	0.2	0.3	0.3	N/A	0.00	38
MEFM-003-045	MEFM-003-045K	0.3	0.45	0.45	N/A	0.00	38
MEFM-004-060	MEFM-004-060K	0.4	0.6	0.6	N/A	0.00	38
MEFM-005-070-05	MEFM-005-070-05K	0.5	0.7	0.7	N/A	0.05	38
MEFM-005-300-05	MEFM-005-300-05K	0.5	0.7	3.0	0.45	0.05	38
MEFM-005-600-05	MEFM-005-600-05K	0.5	0.7	6.0	0.45	0.05	38
MEFM-006-090	MEFM-006-090K	0.6	0.9	0.9	N/A	0.00	38
MEFM-006-300	MEFM-006-300K	0.6	0.9	3.0	0.55	0.00	38
MEFM-006-500	MEFM-006-500K	0.6	0.9	5.0	0.55	0.00	38
MEFM-006-600	MEFM-006-600K	0.6	0.9	6.0	0.55	0.00	38
MEFM-006-090-05	MEFM-006-090-05K	0.6	0.9	0.9	N/A	0.05	38
MEFM-006-300-05	MEFM-006-300-05K	0.6	0.9	3.0	0.55	0.05	38
MEFM-006-500-05	MEFM-006-500-05K	0.6	0.9	5.0	0.55	0.05	38
MEFM-006-600-05	MEFM-006-600-05K	0.6	0.9	6.0	0.55	0.05	38
MEFM-008-120	MEFM-008-120K	0.8	1.2	1.2	N/A	0.00	38
MEFM-008-400	MEFM-008-400K	0.8	1.2	4.0	0.75	0.00	38
MEFM-008-700	MEFM-008-700K	0.8	1.2	7.0	0.75	0.00	38
MEFM-008-900	MEFM-008-900K	0.8	1.2	9.0	0.75	0.00	38
MEFM-008-120-05	MEFM-008-120-05K	0.8	1.2	1.2	N/A	0.05	38
MEFM-008-400-05	MEFM-008-400-05K	0.8	1.2	4.0	0.75	0.05	38
MEFM-008-700-05	MEFM-008-700-05K	0.8	1.2	7.0	0.75	0.05	38
MEFM-008-900-05	MEFM-008-900-05K	0.8	1.2	9.0	0.75	0.05	38
MEFM-010-150	MEFM-010-150K	1.0	1.5	1.5	N/A	0.00	38
MEFM-010-400	MEFM-010-400K	1.0	1.5	4.0	0.95	0.00	38
MEFM-010-700	MEFM-010-700K	1.0	1.5	7.0	0.95	0.00	38
MEFM-010-900	MEFM-010-900K	1.0	1.5	9.0	0.95	0.00	38
MEFM-010-150-10	MEFM-010-150-10K	1.0	1.5	1.5	N/A	0.10	38
MEFM-010-150-20	MEFM-010-150-20K	1.0	1.5	1.5	N/A	0.20	38
MEFM-010-400-10	MEFM-010-400-10K	1.0	1.5	4.0	0.95	0.10	38
MEFM-010-400-20	MEFM-010-400-20K	1.0	1.5	4.0	0.95	0.20	38

♦ WHILE SUPPLIES LAST - Discontinued

FEATURING:

- These precision miniature end mills are ideal for finishing, and semi-finishing cuts and universal milling applications in soft, medium, and hard materials.
- Machine Hardened Materials 45-68 Rc
- Extra Fine Carbide End Mills Engineered for Hard Milling Applications.

End Mills Coated with **nACRo®**
(Nanotech™ CR*)

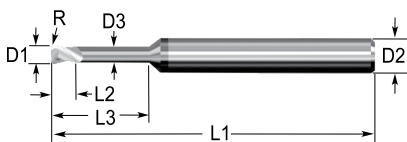
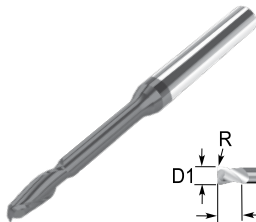

Tolerances (mm):
Shank Diameter: -.0025-.0076
Cutter Diameter: +.0000-.0127
T.I.R. MAX: .0127

Longer necks are reduced neck

MEFM		Cutter Diameter (D1)	Flute Length (L2)	Overall Reach (L3)	Neck Diameter (D3)	Corner Radius (R)	Overall Length (L1)
2 FLUTE Catalog No.							
Uncoated	Coated	mm	mm	mm	mm	mm	mm
3mm Shanks - D2							
MEFM-010-700-10	MEFM-010-700-10K	1.0	1.5	7.0	0.95	0.10	38
MEFM-010-700-20	MEFM-010-700-20K	1.0	1.5	7.0	0.95	0.20	38
MEFM-010-900-10	MEFM-010-900-10K	1.0	1.5	9.0	0.95	0.10	38
MEFM-010-900-20	MEFM-010-900-20K	1.0	1.5	9.0	0.95	0.20	38
MEFM-012-180	MEFM-012-180K	1.2	1.8	1.8	N/A	0.00	38
MEFM-012-600	MEFM-012-600K	1.2	1.8	6.0	1.10	0.00	38
MEFM-012-1000	MEFM-012-1000K	1.2	1.8	10.0	1.10	0.00	38
MEFM-012-1200	MEFM-012-1200K	1.2	1.8	12.0	1.10	0.00	38
MEFM-012-180-10	MEFM-012-180-10K	1.2	1.8	1.8	N/A	0.10	38
MEFM-012-180-20	MEFM-012-180-20K	1.2	1.8	1.8	N/A	0.20	38
MEFM-012-600-10	MEFM-012-600-10K	1.2	1.8	6.0	1.10	0.10	38
MEFM-012-600-20	MEFM-012-600-20K	1.2	1.8	6.0	1.10	0.20	38
MEFM-012-1000-10	MEFM-012-1000-10K	1.2	1.8	10.0	1.10	0.10	38
MEFM-012-1000-20	MEFM-012-1000-20K	1.2	1.8	10.0	1.10	0.20	38
MEFM-012-1200-10	MEFM-012-1200-10K	1.2	1.8	12.0	1.10	0.10	38
MEFM-012-1200-20	MEFM-012-1200-20K	1.2	1.8	12.0	1.10	0.20	38
MEFM-015-220	MEFM-015-220K	1.5	2.2	2.2	N/A	0.00	38
MEFM-015-600	MEFM-015-600K	1.5	2.2	6.0	1.40	0.00	38
MEFM-015-1000	MEFM-015-1000K	1.5	2.2	10.0	1.40	0.00	38
MEFM-015-1200	MEFM-015-1200K	1.5	2.2	12.0	1.40	0.00	38
MEFM-015-1500	MEFM-015-1500K	1.5	2.2	15.0	1.40	0.00	38
MEFM-015-2000	MEFM-015-2000K	1.5	2.2	20.0	1.40	0.00	50
MEFM-015-220-15	MEFM-015-220-15K	1.5	2.2	2.2	N/A	0.15	38
MEFM-015-220-25	MEFM-015-220-25K	1.5	2.2	2.2	N/A	0.25	38
MEFM-015-600-15	MEFM-015-600-15K	1.5	2.2	6.0	1.40	0.15	38
MEFM-015-600-25	MEFM-015-600-25K	1.5	2.2	6.0	1.40	0.25	38
MEFM-015-1000-15	MEFM-015-1000-15K	1.5	2.2	10.0	1.40	0.15	38
MEFM-015-1000-25	MEFM-015-1000-25K	1.5	2.2	10.0	1.40	0.25	38
MEFM-015-1200-15	MEFM-015-1200-15K	1.5	2.2	12.0	1.40	0.15	38
MEFM-015-1200-25	MEFM-015-1200-25K	1.5	2.2	12.0	1.40	0.25	38
MEFM-015-1500-15	MEFM-015-1500-15K	1.5	2.2	15.0	1.40	0.15	38
MEFM-015-1500-25	MEFM-015-1500-25K	1.5	2.2	15.0	1.40	0.25	38
MEFM-015-2000-15	MEFM-015-2000-15K	1.5	2.2	20.0	1.40	0.15	50
MEFM-015-2000-25	MEFM-015-2000-25K	1.5	2.2	20.0	1.40	0.25	50

MEFM

2 Flute, Extra Fine Carbide,
Hard Milling, Miniature End Mills -
Metric

MICRO 100®
super carbide tools

FEATURING:

- These precision miniature end mills are ideal for finishing, and semi-finishing cuts and universal milling applications in soft, medium, and hard materials.
- Machine Hardened Materials 45-68 Rc
- Extra Fine Carbide End Mills Engineered for Hard Milling Applications.

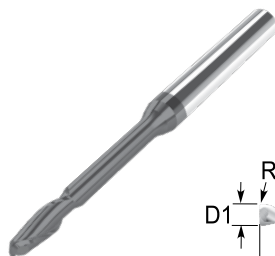

Tolerances (mm):
Shank Diameter: -.0025-.0076
Cutter Diameter: +.0000-.0127
T.I.R. MAX: .0127

Longer necks are reduced neck

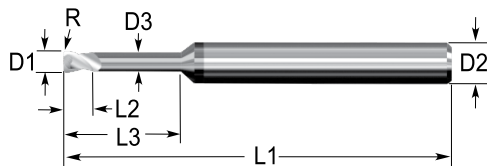

End Mills Coated with

nACRO®

(Nanotech "CR")

MEFM		Cutter Diameter (D1)	Flute Length (L2)	Overall Reach (L3)	Neck Diameter (D3)	Corner Radius (R)	Overall Length (L1)
2 FLUTE Catalog No.							
Uncoated	Coated	mm	mm	mm	mm	mm	mm
3mm Shanks - D2							
MEFM-020-250	MEFM-020-250K	2.0	2.5	2.5	N/A	.00	38
MEFM-020-700	MEFM-020-700K	2.0	2.5	7.0	1.90	.00	38
MEFM-020-1200	MEFM-020-1200K	2.0	2.5	12.0	1.90	.00	38
MEFM-020-1600	MEFM-020-1600K	2.0	2.5	16.0	1.90	.00	38
MEFM-020-2000	MEFM-020-2000K	2.0	2.5	20.0	1.90	.00	50
MEFM-020-2500	MEFM-020-2500K	2.0	2.5	25.0	1.90	.00	50
MEFM-020-250-15	MEFM-020-250-15K	2.0	2.5	2.5	N/A	.15	38
MEFM-020-250-25	MEFM-020-250-25K	2.0	2.5	2.5	N/A	.25	38
MEFM-020-700-15	MEFM-020-700-15K	2.0	2.5	7.0	1.90	.15	38
MEFM-020-700-25	MEFM-020-700-25K	2.0	2.5	7.0	1.90	.25	38
MEFM-020-1200-15	MEFM-020-1200-15K	2.0	2.5	12.0	1.90	.15	38
MEFM-020-1200-25	MEFM-020-1200-25K	2.0	2.5	12.0	1.90	.25	38
MEFM-020-1600-15	MEFM-020-1600-15K	2.0	2.5	16.0	1.90	.15	38
MEFM-020-1600-25	MEFM-020-1600-25K	2.0	2.5	16.0	1.90	.25	38
MEFM-020-2000-15	MEFM-020-2000-15K	2.0	2.5	20.0	1.90	.15	50
MEFM-020-2000-25	MEFM-020-2000-25K	2.0	2.5	20.0	1.90	.25	50
MEFM-020-2500-15	MEFM-020-2500-15K	2.0	2.5	25.0	1.90	.15	50
MEFM-020-2500-25	MEFM-020-2500-25K	2.0	2.5	25.0	1.90	.25	50
MEFM-025-300	MEFM-025-300K	2.5	3.0	3.0	N/A	.00	38
MEFM-025-1000	MEFM-025-1000K	2.5	3.0	10.0	2.40	.00	38
MEFM-025-1500	MEFM-025-1500K	2.5	3.0	15.0	2.40	.00	38
MEFM-025-2000	MEFM-025-2000K	2.5	3.0	20.0	2.40	.00	50
MEFM-025-2500	MEFM-025-2500K	2.5	3.0	25.0	2.40	.00	50
MEFM-025-3000	MEFM-025-3000K	2.5	3.0	30.0	2.40	.00	60
MEFM-025-300-15	MEFM-025-300-15K	2.5	3.0	3.0	N/A	.15	38
MEFM-025-300-25	MEFM-025-300-25K	2.5	3.0	3.0	N/A	.25	38
MEFM-025-1000-15	MEFM-025-1000-15K	2.5	3.0	10.0	2.40	.15	38
MEFM-025-1000-25	MEFM-025-1000-25K	2.5	3.0	10.0	2.40	.25	38
MEFM-025-1500-15	MEFM-025-1500-15K	2.5	3.0	15.0	2.40	.15	38
MEFM-025-1500-25	MEFM-025-1500-25K	2.5	3.0	15.0	2.40	.25	38
MEFM-025-2000-15	MEFM-025-2000-15K	2.5	3.0	20.0	2.40	.15	50
MEFM-025-2000-25	MEFM-025-2000-25K	2.5	3.0	20.0	2.40	.25	50

J

FEATURING:

- These precision miniature end mills are ideal for finishing, and semi-finishing cuts and universal milling applications in soft, medium, and hard materials.
- Machine Hardened Materials 45-68 Rc
- Extra Fine Carbide End Mills Engineered for Hard Milling Applications.



Tolerances (mm):
 Shank Diameter: -.0025-.0076
 Cutter Diameter: +.0000-.0127
 T.I.R. MAX: .0127

Longer necks are reduced neck

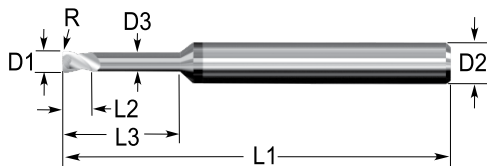

End Mills Coated with **nACRO®**
 (Nanotech "CR")

MEFM		Cutter Diameter (D1)	Flute Length (L2)	Overall Reach (L3)	Neck Diameter (D3)	Corner Radius (R)	Overall Length (L1)
2 FLUTE Catalog No.							
Uncoated	Coated	mm	mm	mm	mm	mm	mm
3mm Shanks - D2							
MEFM-025-2500-15	MEFM-025-2500-15K	2.5	3.0	25.0	2.40	.15	50
MEFM-025-2500-25	MEFM-025-2500-25K	2.5	3.0	25.0	2.40	.25	50
MEFM-025-3000-15	MEFM-025-3000-15K	2.5	3.0	30.0	2.40	.15	60
MEFM-025-3000-25	MEFM-025-3000-25K	2.5	3.0	30.0	2.40	.25	60
6mm Shanks - D2							
MEFM-030-300	MEFM-030-300K	3.0	3.0	3.0	N/A	.00	57
MEFM-030-1000	MEFM-030-1000K	3.0	3.0	10.0	2.90	.00	57
MEFM-030-1500	MEFM-030-1500K	3.0	3.0	15.0	2.90	.00	57
MEFM-030-2500	MEFM-030-2500K	3.0	3.0	25.0	2.90	.00	57
MEFM-030-3000	MEFM-030-3000K	3.0	3.0	30.0	2.90	.00	57
MEFM-030-300-15	MEFM-030-300-15K	3.0	3.0	3.0	N/A	.15	57
MEFM-030-300-25	MEFM-030-300-25K	3.0	3.0	3.0	N/A	.25	57
MEFM-030-1000-15	MEFM-030-1000-15K	3.0	3.0	10.0	2.90	.15	57
MEFM-030-1000-25	MEFM-030-1000-25K	3.0	3.0	10.0	2.90	.25	57
MEFM-030-1500-15	MEFM-030-1500-15K	3.0	3.0	15.0	2.90	.15	57
MEFM-030-1500-25	MEFM-030-1500-25K	3.0	3.0	15.0	2.90	.25	57
MEFM-030-2500-15	MEFM-030-2500-15K	3.0	3.0	25.0	2.90	.15	57
MEFM-030-2500-25	MEFM-030-2500-25K	3.0	3.0	25.0	2.90	.25	57
MEFM-030-3000-15	MEFM-030-3000-15K	3.0	3.0	30.0	2.90	.15	57
MEFM-030-3000-25	MEFM-030-3000-25K	3.0	3.0	30.0	2.90	.25	57
MEFM-040-500	MEFM-040-500K	4.0	5.0	5.0	N/A	.00	57
MEFM-040-1500	MEFM-040-1500K	4.0	5.0	15.0	3.90	.00	57
MEFM-040-2500	MEFM-040-2500K	4.0	5.0	25.0	3.90	.00	57
MEFM-040-3000	MEFM-040-3000K	4.0	5.0	30.0	3.90	.00	57
MEFM-040-500-25	MEFM-040-500-25K	4.0	5.0	5.0	N/A	.25	57
MEFM-040-500-50	MEFM-040-500-50K	4.0	5.0	5.0	N/A	.50	57
MEFM-040-500-100	MEFM-040-500-100K	4.0	5.0	5.0	N/A	1.00	57
MEFM-040-1500-25	MEFM-040-1500-25K	4.0	5.0	15.0	3.90	.25	57
MEFM-040-1500-50	MEFM-040-1500-50K	4.0	5.0	15.0	3.90	.50	57
MEFM-040-1500-100	MEFM-040-1500-100K	4.0	5.0	15.0	3.90	1.00	57

For current pricing and availability please visit our website at www.micro100.com

MEFM

2 Flute, Extra Fine Carbide,
Hard Milling, Miniature End Mills -
Metric

MICRO 100®
super carbide tools

FEATURING:

- These precision miniature end mills are ideal for finishing, and semi-finishing cuts and universal milling applications in soft, medium, and hard materials.
- Machine Hardened Materials 45-68 Rc
- Extra Fine Carbide End Mills Engineered for Hard Milling Applications.



Tolerances (mm):
Shank Diameter:
-0.025-.0076
Cutter Diameter:
+0.000-.0127
T.I.R. MAX: .0127

*Longer necks are
reduced neck*

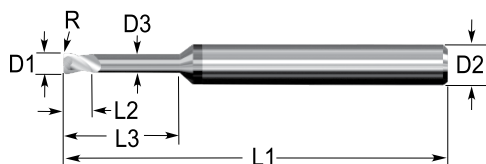

End Mills Coated with
nACRo®
(Nanotech "CR")

MEFM		Cutter Diameter (D1)	Flute Length (L2)	Overall Reach (L3)	Neck Diameter (D3)	Corner Radius (R)	Overall Length (L1)
2 FLUTE Catalog No.							
Uncoated	Coated	mm	mm	mm	mm	mm	mm
6mm Shanks - D2							
MEFM-040-2500-25	MEFM-040-2500-25K	4.0	5.0	25.0	3.90	0.25	57
MEFM-040-2500-50	MEFM-040-2500-50K	4.0	5.0	25.0	3.90	0.50	57
MEFM-040-2500-100	MEFM-040-2500-100K	4.0	5.0	25.0	3.90	1.00	57
MEFM-040-3000-25	MEFM-040-3000-25K	4.0	5.0	30.0	3.90	0.25	57
MEFM-040-3000-50	MEFM-040-3000-50K	4.0	5.0	30.0	3.90	0.50	57
MEFM-040-3000-100	MEFM-040-3000-100K	4.0	5.0	30.0	3.90	1.00	57
MEFM-050-600	MEFM-050-600K	5.0	6.0	6.0	N/A	0.00	57
MEFM-050-1500	MEFM-050-1500K	5.0	6.0	15.0	4.90	0.00	57
MEFM-050-2500	MEFM-050-2500K	5.0	6.0	25.0	4.90	0.00	57
MEFM-050-300	MEFM-050-300K	5.0	6.0	30.0	4.90	0.00	57
MEFM-050-600-25	MEFM-050-600-25K	5.0	6.0	6.0	N/A	0.25	57
MEFM-050-600-50	MEFM-050-600-50K	5.0	6.0	6.0	N/A	0.50	57
MEFM-050-600-100	MEFM-050-600-100K	5.0	6.0	6.0	N/A	1.00	57
MEFM-050-1500-25	MEFM-050-1500-25K	5.0	6.0	15.0	4.90	0.25	57
MEFM-050-1500-50	MEFM-050-1500-50K	5.0	6.0	15.0	4.90	0.50	57
MEFM-050-1500-100	MEFM-050-1500-100K	5.0	6.0	15.0	4.90	1.00	57
MEFM-050-2500-25	MEFM-050-2500-25K	5.0	6.0	25.0	4.90	0.25	57
MEFM-050-2500-50	MEFM-050-2500-50K	5.0	6.0	25.0	4.90	0.50	57
MEFM-050-2500-100	MEFM-050-2500-100K	5.0	6.0	25.0	4.90	1.00	57
MEFM-050-3000-25	MEFM-050-3000-25K	5.0	6.0	30.0	4.90	0.25	57
MEFM-050-3000-50	MEFM-050-3000-50K	5.0	6.0	30.0	4.90	0.50	57
MEFM-050-3000-100	MEFM-050-3000-100K	5.0	6.0	30.0	4.90	1.00	57

For current pricing and availability please visit our website at www.micro100.com

FEATURING:

- These high precision end mills feature multiple corner radii and multiple neck length dimensions in a wide range of cutting diameters to provide the best available geometry for finishing cuts in mold making applications.
- A positive rake angle supports maximum cutting performance in medium and hard materials for conventional side milling and slotting.



Tolerances (mm):
Shank Diameter: -.025-.0076
Cutter Diameter: h8
Tool Radius: ±.013
T.I.R. MAX: .013

Page 274
for Coating
Info

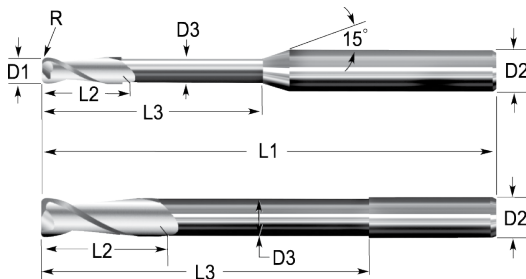

AITiN – Add “X” to the end of Catalog No.

MMRM	Cutter Diameter (D1)	Flute Length (L2)	Reduced Neck Diameter (D3)	Overall Reach (L3)	Corner Radius (R)	Overall Length (L1)
2 FLUTE Catalog No.	mm	mm	mm	mm	mm	mm
4mm Shanks - D2						
MMRM-005-5	0.5	0.5	0.48	5	0.05	50
MMRM-005-10	0.5	0.5	0.48	10	0.05	50
MMRM-006-12	0.6	0.6	0.58	12	0.05	50
MMRM-008-5	0.8	0.8	0.78	5	0.10	50
MMRM-008-10	0.8	0.8	0.78	10	0.10	50
MMRM-008-16	0.8	0.8	0.78	16	0.10	50
6mm Shanks - D2						
MMRM-010-5	1.0	1.0	0.95	5	0.10	57
MMRM-010-8	1.0	1.0	0.95	8	0.10	57
MMRM-010-10	1.0	1.0	0.95	10	0.10	57
MMRM-010-12	1.0	1.0	0.95	12	0.10	57
MMRM-010-20	1.0	1.0	0.95	20	0.10	57
MMRM-012-15	1.2	1.2	1.15	15	0.10	57
MMRM-012-20	1.2	1.2	1.15	20	0.10	57
MMRM-015-7	1.5	1.5	1.45	7	0.15	57
MMRM-015-15	1.5	1.5	1.45	15	0.15	57
MMRM-015-25	1.5	1.5	1.45	25	0.15	72

For current pricing and availability please visit our website at www.micro100.com

MMRM
 2 Flute, Center Cutting, 30° Helix,
 Mold Making End Mills
 - Metric



FEATURING:

- These high precision end mills feature multiple corner radii and multiple neck length dimensions in a wide range of cutting diameters to provide the best available geometry for finishing cuts in mold making applications.
- A positive rake angle supports maximum cutting performance in medium and hard materials for conventional side milling and slotting.

Tolerances (mm):
 Shank Diameter: $-.002-.0076$
 Cutter Diameter: $h8$
 Tool Radius: $\pm .013$
 T.I.R. MAX: $.013$

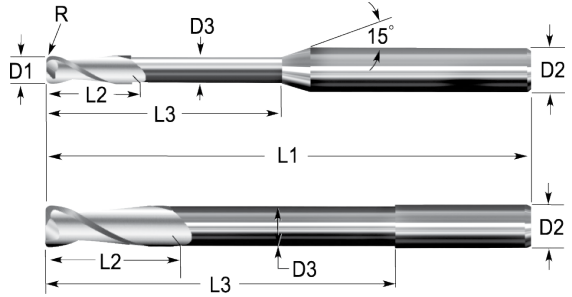
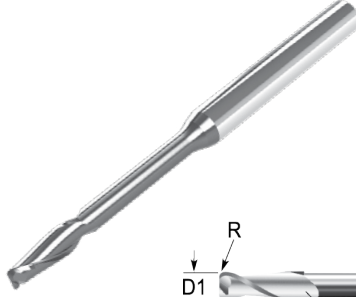

Page 274
 for Coating
 Info

AITiN – Add “X” to the end of Catalog No.

MMRM	Cutter Diameter (D1)	Flute Length (L2)	Reduced Neck Diameter (LD3)	Reduced Neck Length (L3)	Corner Radius (R)	Overall Length (L1)
2 FLUTE Catalog No.	mm	mm	mm	mm	mm	mm
6mm Shanks - D2						
MMRM-020-7	2.0	2.0	1.90	7	0.20	57
MMRM-020-15	2.0	2.0	1.90	15	0.20	57
MMRM-020-30	2.0	2.0	1.90	30	0.20	72
MMRM-030-8	3.0	3.0	2.90	8	0.25	57
MMRM-030-15	3.0	3.0	2.90	15	0.25	57
MMRM-030-30	3.0	3.0	2.90	30	0.25	72
MMRM-040-9	4.0	4.0	3.80	9	0.25	57
MMRM-040-15	4.0	4.0	3.80	15	0.25	57
MMRM-040-30	4.0	4.0	3.80	30	0.25	72
MMRM-050-10	5.0	5.0	4.80	10	.050	57
MMRM-050-15	5.0	5.0	4.80	15	.050	57
MMRM-050-30	5.0	5.0	4.80	30	.050	72
MMRM-060-11	6.0	6.0	5.80	11	1.00	57
MMRM-060-16	6.0	6.0	5.80	16	1.00	57
MMRM-060-30	6.0	6.0	5.80	30	1.00	72
8mm Shanks - D2						
MMRM-080-16	8.0	8.0	7.80	16	1.00	63
MMRM-080-25	8.0	8.0	7.80	25	1.00	72
10mm Shanks - D2						
MMRM-100-20	10.0	10.0	9.80	20	1.00	72
MMRM-100-25	10.0	10.0	9.80	25	1.00	72
12mm Shanks - D2						
MMRM-120-25	12.0	12.0	11.80	25	1.50	83

For current pricing and availability please visit our website at www.micro100.com

Tolerances (mm):

Shank Diameter: -.0025-.0076

Cutter Diameter:
h8

T.I.R MAX: .013

Page 274
for Coating
Info

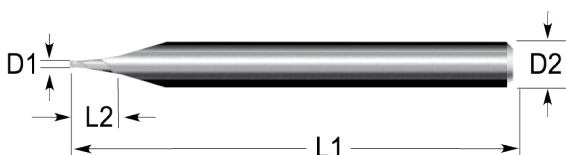

AITIN – Add “X” to the end of Catalog No.

BMRM		Cutter Diameter (D1)	Flute Length (L2)	Overall Length (L1)	BMSM		Cutter Diameter (D1)	Flute Length (L2)	Overall Length (L1)
2 FLUTE Catalog No.	4 FLUTE Catalog No.				2 FLUTE Catalog No.	4 FLUTE Catalog No.			
4mm Shanks - D2					3mm Shanks - D2				
-	-				BMSM-003-2	-	0.3	0.5	38
-	-				BMSM-004-2	-	0.4	0.6	38
BMRM-005-2	-	0.5	1.5	50	BMSM-005-2	-	0.5	0.8	38
BMRM-006-2	-	0.6	1.8	50	BMSM-006-2	-	0.6	0.9	38
BMRM-007-2	-	0.7	2.1	50	BMSM-007-2	-	0.7	1.1	38
BMRM-008-2	-	0.8	2.4	50	BMSM-008-2	-	0.8	1.2	38
BMRM-009-2	-	0.9	2.7	50	BMSM-009-2	-	0.9	1.4	38
BMRM-010-2	BMRM-010-4	1.0	3.0	50	BMSM-010-2	BMSM-010-4	1.0	1.5	38
BMRM-011-2	BMRM-011-4	1.1	3.3	50	BMSM-011-2 ♦	-	1.1	1.7	38
	BMRM-012-4 ♦	1.2	3.8	50	-	BMSM-012-4 ♦	1.2	1.8	38
BMRM-013-2 ♦	BMRM-013-4	1.3	3.9	50	BMSM-013-2	BMSM-013-4 ♦	1.3	2.0	38
BMRM-015-2	BMRM-015-4	1.5	4.2	50	BMSM-014-2 ♦	-	1.4	2.1	38
BMRM-016-2	-	1.6	4.8	50	BMSM-015-2	BMSM-015-4 ♦	1.5	2.3	38
BMRM-018-2 ♦	BMRM-018-4	1.8	5.3	50	BMSM-016-2	BMSM-016-4 ♦	1.6	2.4	38
BMRM-020-2	BMRM-020-4	2.0	6.0	50	BMSM-017-2 ♦	BMSM-017-4	1.7	2.5	38
BMRM-025-2	-	2.5	8.0	50	BMSM-018-2	BMSM-018-4 ♦	1.8	2.7	38
BMRM-030-2	BMRM-030-4	3.0	9.0	50	BMSM-019-2	BMSM-019-4	1.9	2.8	38
BMRM-035-2	-	3.5	10.5	50	BMSM-020-2	BMSM-020-4 ♦	2.0	3.0	38
-	-				BMSM-025-2	BMSM-025-4 ♦	2.5	3.8	38

♦ WHILE SUPPLIES LAST - Discontinued

For current pricing and availability please visit our website at www.micro100.com

FEATURING:

- These precision miniature end mills are ideal for finishing, and semi-finishing cuts and universal milling applications in soft, medium, and hard materials.
- Machine Hardened Materials 45-68 Rc

Page 274
 for Coating
 Info



Tolerances (mm):
 Shank Diameter:
 -.0025-.0076
 Cutter Diameter: h8
 T.I.R. MAX: .0127

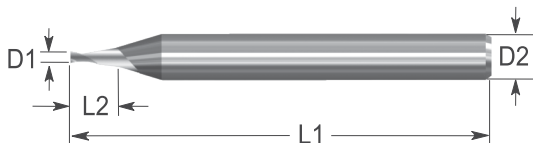

AITiN – Add “X” to the end of Catalog No.

AMRM	Cutter Diameter (D1)	Flute Length (L2)	Overall Length (L1)
2 FLUTE			
Catalog No.	mm	mm	fraction
4mm Shanks - D2			
AMRM-002-2	0.2	0.4	50
AMRM-003-2	0.3	0.9	50
AMRM-004-2	0.4	1.2	50
AMRM-005-2	0.5	1.5	50
AMRM-006-2 ♦	0.6	1.8	50
AMRM-007-2	0.7	2.1	50
AMRM-008-2	0.8	2.4	50
AMRM-009-2 ♦	0.9	2.7	50
AMRM-010-2	1.0	3.0	50
AMRM-011-2	1.1	3.3	50
AMRM-012-2	1.2	3.8	50
AMRM-013-2	1.3	3.9	50
AMRM-014-2	1.4	4.2	50
AMRM-015-2	1.5	4.2	50
AMRM-016-2	1.6	4.8	50
AMRM-017-2	1.7	5.1	50
AMRM-018-2	1.8	5.3	50
AMRM-019-2	1.9	5.7	50
AMRM-020-2	2.0	6.0	50
AMRM-025-2	2.5	8.0	50
AMRM-030-2	3.0	9.0	50
AMRM-035-2 ♦	3.5	10.5	50

♦ WHILE SUPPLIES LAST - Discontinued

For current pricing and availability please visit our website at www.micro100.com

FEATURING:

- These precision miniature end mills are ideal for finishing, and semi-finishing cuts and universal milling applications in soft, medium, and hard materials.
- Machine Hardened Materials 45-68 Rc



Tolerances (mm):
Shank Diameter:
-.0025-.0076
Cutter Diameter: h8
T.I.R. MAX: .0127

Page 274
for Coating
Info

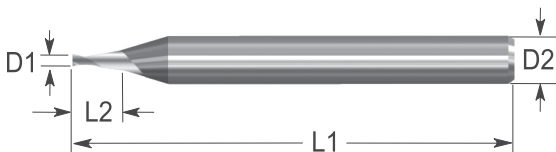

AITiN – Add “X” to the end of Catalog No.

RMEM	Cutter Diameter (D1)	Flute Length (L2)	Overall Length (L1)
2 FLUTE Catalog No.	mm	mm	fraction
3mm Shanks - D2			
RMEM-002-2	0.2	0.4	50
RMEM-003-2	0.3	0.9	50
RMEM-004-2	0.4	1.2	50
RMEM-005-2	0.5	1.5	50
RMEM-006-2	0.6	1.8	50
RMEM-007-2	0.7	2.1	50
RMEM-008-2	0.8	2.4	50
RMEM-009-2	0.9	2.7	50
RMEM-010-2	1.0	3.0	50
RMEM-011-2	1.1	3.3	50
RMEM-012-2	1.2	3.8	50
RMEM-013-2	1.3	3.9	50
RMEM-014-2	1.4	4.2	50
RMEM-015-2	1.5	4.2	50
RMEM-016-2	1.6	4.8	50
RMEM-017-2	1.7	5.1	50
RMEM-018-2	1.8	5.3	50
RMEM-019-2	1.9	5.7	50
RMEM-020-2	2.0	6.0	50
RMEM-025-2	2.5	8.0	50

For current pricing and availability please visit our website at www.micro100.com

FEATURING:

- These universal application type end mills feature a slightly increased flute and overall length for greatest versatility.
- Engineered with various corner radii per cutting diameter, these end mills are **ideally suited for heavier cuts in medium and hard materials.**

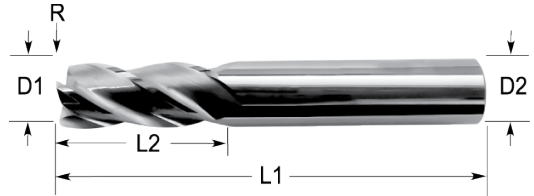
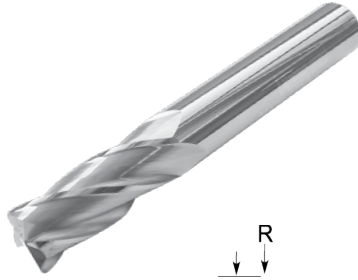

Tolerances (mm):
Shank Diameter: -.0025-.0076
Cutter Diameter:
1-6: h8
8-12: h9
Tool Radius: ±.013
T.I.R. MAX: .013

AITIN – Add “X” to the end of Catalog No.

AECM	Cutter Diameter (D1)	Flute Length (L2)	Corner Radius (R)	Overall Length (L1)
4 FLUTE Catalog No.	mm	mm	mm	mm
4mm Shanks - D2				
AECM-0101-4	1	4	0.1	50
AECM-0102-4	1	4	0.2	50
AECM-0202-4	2	5	0.2	50
AECM-0205-4	2	5	0.5	50
6mm Shanks - D2				
AECM-0305-4	3	8	0.5	57
AECM-0402-4	4	11	0.2	57
AECM-0405-4	4	11	0.5	57
AECM-0603-4	6	16	0.3	57
AECM-0605-4	6	16	0.5	57
AECM-0610-4	6	16	1.0	57
8mm Shanks - D2				
AECM-0805-4	8	22	0.5	63
AECM-0810-4	8	22	1.0	63
AECM-0815-4	8	22	1.5	63
10mm Shanks - D2				
AECM-1005-4	10	25	0.5	72
AECM-1010-4 ♦	10	25	1.0	72
12mm Shanks - D2				
AECM-1205-4	12	30	0.5	83
AECM-1210-4	12	30	1.0	83
AECM-1215-4	12	30	1.5	83

♦ WHILE SUPPLIES LAST - Discontinued

For current pricing and availability please visit our website at www.micro100.com

FEATURING:

- These universal application type end mills feature a slightly increases flute and overall length for greatest versatility.
- Engineered with various corner radii per cutting diameter, these end mills are **ideally suited for heavier cuts in medium and hard materials.**

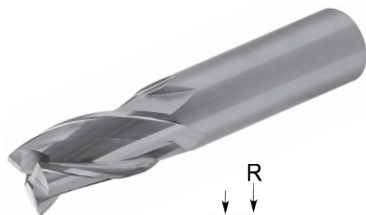

Tolerances (mm):
 Shank Diameter: -.002-.0076
 Cutter Diameter:
 1-7: h8
 8-25: h9
 T.I.R. MAX: .013

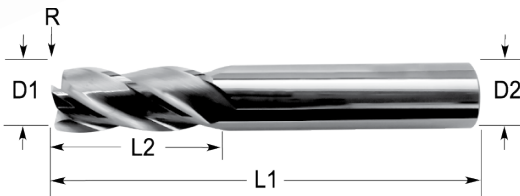

AITiN – Add “X” to the end of Catalog No.

AEMM			Cutter Diameter (D1)	Flute Length (L2)	Overall Length (L1)
2 FLUTE Catalog No.	3 FLUTE Catalog No.	4 FLUTE Catalog No.			
			mm	mm	mm
4mm Shanks - D2					
AEMM-010-2	AEMM-010-3	AEMM-010-4	1.0	4	50
AEMM-015-2	AEMM-015-3	AEMM-015-4	1.5	4	50
AEMM-020-2	AEMM-020-3	AEMM-020-4	2.0	5	50
AEMM-025-2	AEMM-025-3	AEMM-025-4	2.5	6	50
6mm Shanks - D2					
AEMM-030-2	AEMM-030-3	AEMM-030-4	3.0	8	57
AEMM-035-2	AEMM-035-3	AEMM-035-4	3.5	10	57
AEMM-040-2	AEMM-040-3	AEMM-040-4	4.0	11	57
-	AEMM-045-3	AEMM-045-4	4.5	11	57
AEMM-050-2	AEMM-050-3	AEMM-050-4	5.0	16	57
AEMM-055-2	AEMM-055-3	AEMM-055-4	5.5	16	57
AEMM-060-2	AEMM-060-3	AEMM-060-4	6.0	16	57
8mm Shanks - D2					
-	AEMM-070-3	AEMM-070-4	7.0	22	63
AEMM-080-2	AEMM-080-3	AEMM-080-4	8.0	22	63
10mm Shanks - D2					
AEMM-090-2 ♦	-	-	9.0	22	72
AEMM-100-2	AEMM-100-3	AEMM-100-4	10.0	22	72
12mm Shanks - D2					
AEMM-110-2 ♦	AEMM-110-3 ♦	-	11.0	30	83
AEMM-120-2	AEMM-120-3	AEMM-120-4	12.0	30	83
14mm Shanks - D2					
AEMM-140-2	AEMM-140-3	AEMM-140-4	14.0	35	83
16mm Shanks - D2					
-	AEMM-160-3	AEMM-160-4	16.0	35	92
18mm Shanks - D2					
AEMM180-2 ♦	AEMM-180-3 ♦	-	18.0	45	92
20mm Shanks - D2					
AEMM-200-2 ♦	AEMM-200-3	AEMM-200-4	20.0	45	104
25mm Shanks - D2					
AEMM-250-2 ♦	AEMM-250-3 ♦	AEMM-250-4	25.0	50	127

♦ WHILE SUPPLIES LAST - Discontinued

FEATURING:

- These end mills feature a +.025mm plus tolerance on the cutting diameter.

Tolerances (mm):
 Shank Diameter: -.0025-.0076
 Cutter Diameter: +.025-.000
 T.I.R. MAX: .013

**Page 274
 for Coating
 Info**

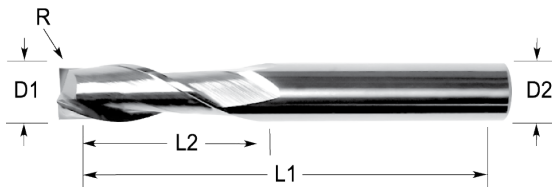

AITiN – Add “X” to the end of Catalog No.

EMSM			Cutter Diameter (D1)	Flute Length (L2)	Overall Length (L1)
2 FLUTE Catalog No.	3 FLUTE Catalog No.	4 FLUTE Catalog No.			
2mm Shanks - D2			mm	mm	mm
EMSM-020-2	EMSM-020-3	EMSM-020-4	2	10	38
3mm Shanks - D2					
EMSM-030-2	–	EMSM-030-4	3	15	38
4mm Shanks - D2					
EMSM-040-2	–	EMSM-040-4	4	18	50
6mm Shanks - D2					
EMSM-060-2	–	EMSM-060-4	6	18	57
8mm Shanks - D2					
EMSM-080-2 ♦	EMSM-080-3 ♦	EMSM-080-4 ♦	8	22	63
10mm Shanks - D2					
EMSM-100-2 ♦	EMSM-100-3 ♦	EMSM-100-4 ♦	10	25	72
12mm Shanks - D2					
–	EMSM-120-3 ♦	–	12	30	83
16mm Shanks - D2					
EMSM-160-2 ♦	EMSM-160-3 ♦	–	16	35	92
20mm Shanks - D2					
–	EMSM-200-3 ♦	EMSM-200-4 ♦	20	45	104

♦ WHILE SUPPLIES LAST - Discontinued

For current pricing and availability please visit our website at www.micro100.com

FEATURING:

- These universal application type end mills feature a slightly increased flute and overall length for greatest versatility.
- The conventional tool geometry supports applications in a wide scope of different materials, ranging from soft to hard.



Tolerances (mm):
Shank Diameter: -.0025-.0076
Cutter Diameter: h9
T.I.R. MAX: .013

**Page 274
for Coating
Info**

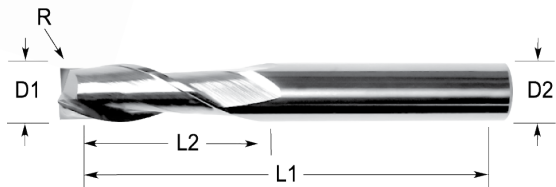

AITiN – Add “X” to the end of Catalog No.

GEMM			Cutter Diameter (D1)	Flute Length (L2)		Overall Length (L1)
2 FLUTE Catalog No.	3 FLUTE Catalog No.	4 FLUTE Catalog No.		2/3 flute	4 flute	
3mm Shanks - D2						
GEMM-010-2	GEMM-010-3	GEMM-010-4	1	3	3	38
GEMM-020-2	GEMM-020-3	GEMM-020-4	2	6	7	38
GEMM-030-2	GEMM-030-3	GEMM-030-4	3	7	8	38
4mm Shanks - D2						
GEMM-040-2	GEMM-040-3	GEMM-040-4	4	8	11	50
6mm Shanks - D2						
GEMM-050-2	–	GEMM-050-4	5	10	13	57
GEMM-060-2	GEMM-060-3	GEMM-060-4	6	10	13	57
8mm Shanks - D2						
GEMM-080-2	–	GEMM-080-4	8	16	19	63
10mm Shanks - D2						
GEMM-100-2	GEMM-100-3	GEMM-100-4	10	19	22	72
12mm Shanks - D2						
GEMM-120-2	GEMM-120-3	GEMM-120-4	12	22	26	83
14mm Shanks - D2						
GEMM-140-2 ♦	GEMM-140-3 ♦	GEMM-140-4 ♦	14	22	26	83
16mm Shanks - D2						
GEMM-160-2	–	GEMM-160-4	16	26	32	92
18mm Shanks - D2						
GEMM-180-2 ♦	GEMM-180-3 ♦	GEMM-180-4	18	26	32	92
20mm Shanks - D2						
–	GEMM-200-3 ♦	GEMM-200-4	20	32	38	104

♦ WHILE SUPPLIES LAST - Discontinued

For current pricing and availability please visit our website at www.micro100.com

FEATURING:

- These high performance end mills feature a 45° helix and are engineered for high speed cutting in aluminum, non-ferrous and soft materials.
- The special flute geometry provides an extremely smooth and silent cutting action for an exceptional surface finish.

Page 274
for Coating
Info

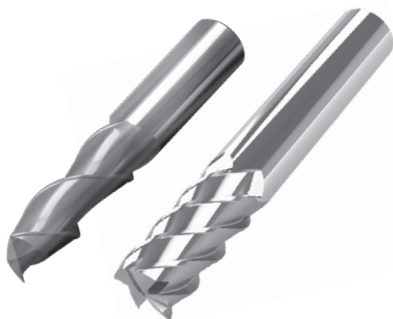

Tolerances (mm):
Shank Diameter: -.0025-.0076
Cutter Diameter: h8
T.I.R. MAX: .013

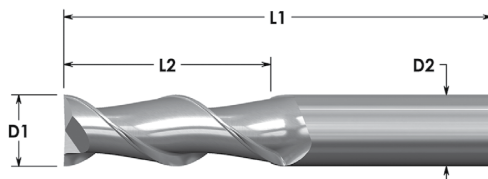

ZrN – Add “S” to the end of Catalog No.
(Only for 2/3 Fluted End Mills)

AlTiN – Add “X” to the end of Catalog No.
(Only for 5 Fluted End Mills)

ASMM		Cutter Diameter (D1)	Flute Length (L2)	Overall Length (L1)
2 FLUTE Catalog No.	5 FLUTE Catalog No.			
4mm Shanks - D2				
ASMM-020-2 ♦	–	2	4	50
6mm Shanks - D2				
ASMM-030-2	ASMM-030-5	3	6	57
–	ASMM-040-5	4	8	57
ASMM-050-2 ♦	ASMM-050-5	5	10	57
ASMM-060-2	ASMM-060-5	6	10	57
8mm Shanks - D2				
–	ASMM-080-5	8	16	63
10mm Shanks - D2				
ASMM-100-2 ♦	ASMM-100-5	10	19	72
12mm Shanks - D2				
–	ASMM-120-5 ♦	12	22	83

♦ WHILE SUPPLIES LAST - Discontinued

For current pricing and availability please visit our website at www.micro100.com

FEATURING:

- These end mills feature a 45° helix for **roughing, finishing, and slotting** in medium to hard steels, stainless steels, and high temperature alloys.
- The high helix angle **aids in reducing chatter** and helps to increase metal removal rates, while **providing the highest surface finish quality.**



Tolerances (mm):
Shank Diameter: -.0025-.0076
Cutter Diameter: h8
T.I.R. MAX: .013

**Page 274
for Coating
Info**

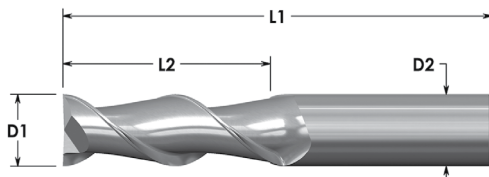

ZrN – Add “S” to the end of Catalog No.
(Only for 2/3 Fluted End Mills)

AlTiN – Add “X” to the end of Catalog No.
(Only for 5 Fluted End Mills)

ARMM			Cutter Diameter (D1)	Flute Length (L2)	Overall Length (L1)
2 FLUTE Catalog No.	3 FLUTE Catalog No.	5 FLUTE Catalog No.			
			mm	mm	mm
4mm Shanks - D2					
ARMM-010-2	–	–	1	3	50
ARMM-020-2	–	–	2	6	50
6mm Shanks - D2					
ARMM-030-2	–	ARMM-030-5	3	10	57
ARMM-040-2	–	ARMM-040-5	4	15	57
ARMM-050-2	–	–	5	20	57
ARMM-060-2	ARMM-060-3	ARMM-060-5	6	20	57
8mm Shanks - D2					
ARMM-080-2	ARMM-080-3	ARMM-080-5	8	25	63
10mm Shanks - D2					
ARMM-100-2	ARMM-100-3	ARMM-100-5	10	25	72
12mm Shanks - D2					
ARMM-120-2	ARMM-120-3	–	12	30	83
16mm Shanks - D2					
ARMM-160-2	ARMM-160-3 ♦	ARMM-160-5	16	35	92
18mm Shanks - D2					
ARMM-180-2 ♦	ARMM-180-3 ♦	ARMM-180-4 ♦	18	45	92
20mm Shanks - D2					
ARMM-200-2	ARMM-200-3	ARMM-200-5	20	45	104

♦ WHILE SUPPLIES LAST - Discontinued

For current pricing and availability please visit our website at www.micro100.com

HMSM/HMRM

4 Flute, Center Cutting, Hard Milling,
Stub / Regular Length End Mills
- Metric



FEATURING:

- Engineered with special 4 flute stub length tool geometry, specifically suitable for milling operations with a shallow cutting depth in hard materials
- The unique tool geometry provides maximum milling performance in semi-finishing and finishing as well as in roughing cuts.

Page 274
for Coating
Info



Tolerances (mm):
Shank Diameter: -.0025-.0076
Cutter Diameter: h8
T.I.R. MAX: .013

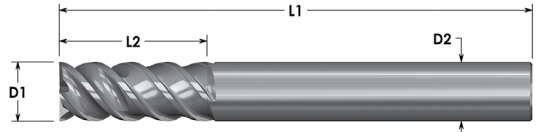

End Mills Coated with: AITiN

HMSM 4 FLUTE Catalog No.	Cutter Diameter (D1)	Flute Length (L2)	Overall Length (L1)
	mm	mm	mm
6mm Shanks - D2			
HMSM-030-4X ♦	3	4.5	57
HMSM-040-4X ♦	4	6	57
HMSM-050-4X ♦	5	7.5	57
HMSM-060-4X ♦	6	9	57
8mm Shanks - D2			
HMSM-080-4X ♦	8	12	75
10mm Shanks - D2			
HMSM-100-4X ♦	10	15	80
12mm Shanks - D2			
HMSM120-4X ♦	12	18	100
16mm Shanks - D2			
HMSM-160-4X ♦	16	24	110
20mm Shanks - D2			
HMSM-200-4X ♦	20	30	125

HMRM 4 FLUTE Catalog No.	Cutter Diameter (D1)	Flute Length (L2)	Overall Length (L1)
	mm	mm	mm
12mm Shanks - D2			
HMRM-120-4X ♦	12	26	100
16mm Shanks - D2			
HMRM-160-4X ♦	16	32	110
20mm Shanks - D2			
HMRM-200-4X ♦	20	38	125

♦ WHILE SUPPLIES LAST - Discontinued

For current pricing and availability please visit our website at www.micro100.com

FEATURING:

- Engineered with negative rake angle, these high-tech end mills are specifically engineered for numerous milling applications in hard materials.
- The unique tool geometry provides maximum milling performance in semi-finishing and finishing as well as in roughing cuts.



Tolerances (mm):
Shank Diameter: -.0025-.0076
Cutter Diameter: h8
T.I.R. MAX: .013

**Page 274
for Coating
Info**

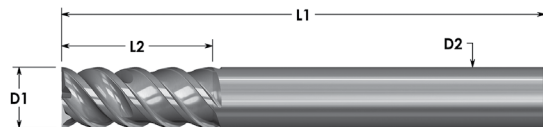

End Mills Coated with:

AlTiN

HMUM 4 FLUTE Catalog No.	Cutter Diameter (D1)	Flute Length (L2)	Overall Length (L1)
	mm	mm	mm
6mm Shanks - D2			
HMUM-040-4X ♦	4	12	57
HMUM-060-4X ♦	6	15	57
8mm Shanks - D2			
HMUM-080-4X ♦	8	20	75
10mm Shanks - D2			
HMUM-100-4X ♦	10	25	80
12mm Shanks - D2			
HMUM-120-4X ♦	12	30	100
16mm Shanks - D2			
HMUM-160-4X ♦	16	40	110
20mm Shanks - D2			
HMUM-200-4X ♦	20	45	125

♦ WHILE SUPPLIES LAST - Discontinued

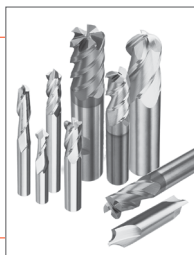

MICRO 100[®]
super carbide tools

World Class Quality
Carbide Tooling Through
Manufacturing Excellence!

For current pricing and availability please visit our website at www.micro100.com

SDHM
3 & 4 Flute,
60° Helix End Mills
- Metric



FEATURING:

- These 60° high helix end mills generate the highest metal removal rate in most applications.
- The 3 flute geometry is ideal for roughing and slotting in all mild steels and stainless steels.
- The 4 flute geometry is ideally suited for milling inconel, waspalloy, titanium, and high temperature alloys.

Page 274
for Coating
Info



Tolerances (mm):
Shank Diameter: -.0025-.0076
Cutter Diameter: h9
T.I.R. MAX: .013

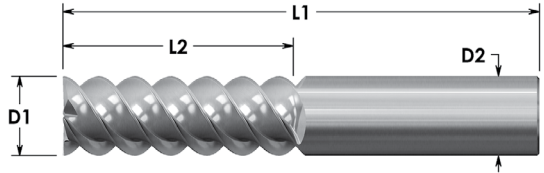

AITiN – Add “X” to the end of Catalog No.

SDHM		Cutter Diameter (D1)	Flute Length (L2)	Overall Length (L1)
3 FLUTE Catalog No.	4 FLUTE Catalog No.			
		mm	mm	mm
6mm Shanks - D2				
SDHM-050-3 ♦	–	5	15	57
SDHM-060-3	–	6	18	57
8mm Shanks - D2				
SDHM-080-3	–	8	22	63
10mm Shanks - D2				
SDHM-100-3	SDHM-100-4	10	25	72
12mm Shanks - D2				
SDHM-120-3	SDHM-120-4	12	30	83
14mm Shanks - D2				
SDHM-140-3 ♦	–	14	35	83
16mm Shanks - D2				
SDHM-160-3	SDHM-160-4 ♦	16	35	92
20mm Shanks - D2				
SDHM-200-3 ♦	SDHM-200-4 ♦	20	35	104

♦ WHILE SUPPLIES LAST - Discontinued

For current pricing and availability please visit our website at www.micro100.com

FEATURING:

- These 38° helix end mills provide a superior work piece finish in all milling applications.
- These end mills are very suitable for milling steels, stainless steels, and heat treated materials.
- The 6 flute geometry provides excellent shearing action, resulting in the highest dimensional accuracy and reduced work piece distortion, especially in thin wall slotting applications.

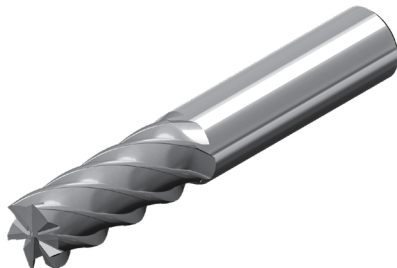

Tolerances (mm):
Shank Diameter: -.0025-.0076
Cutter Diameter: h9
T.I.R. MAX: .013

Page 274
for Coating
Info

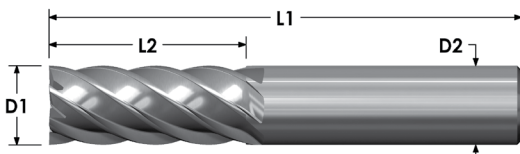

AITiN – Add “X” to the end of Catalog No.

EMHM		Cutter Diameter (D1)	Flute Length (L2)	Overall Length (L1)
4 FLUTE Catalog No.	6 FLUTE Catalog No.			
		mm	mm	mm
4mm Shanks - D2				
EMHM-030-4	–	3	8	50
EMHM-040-4	–	4	12	50
6mm Shanks - D2				
EMHM-050-4	–	5	15	57
EMHM-060-4	EMHM-060-6	6	18	57
8mm Shanks - D2				
EMHM-080-4	EMHM-080-6	8	20	63
10mm Shanks - D2				
EMHM-100-4	EMHM-100-6	10	22	72
12mm Shanks - D2				
EMHM-120-4	EMHM-120-6	12	25	83
14mm Shanks - D2				
–	EMHM-140-6	14	30	83
16mm Shanks - D2				
–	EMHM-160-6	16	35	92
20mm Shanks - D2				
–	EMHM-200-6	20	45	104

For current pricing and availability please visit our website at www.micro100.com

SALM/SARM

3 Flute, 38° Helix, Regular / Long Length, Roughing End Mills for Aluminum - Metric

MICRO 100®
super carbide tools

FEATURING:

- Designed and engineered to generate **maximum metal removal rates** in most applications.

Page 274
for Coating
Info

THE SHREDDER

Tolerances (mm):
Shank Diameter: -.0025-.0076
Cutter Diameter: h9
T.I.R. MAX: .013

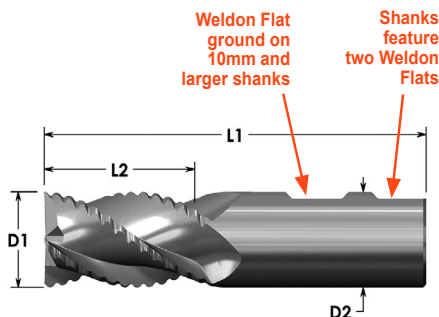

ZrN – Add “S” to the end of Catalog No.

SARM 3 FLUTE Catalog No.	Cutter Diameter (D1) mm	Flute Length (L2) mm	Overall Length (L1) mm
14mm Shanks - D2			
SARM-140-3 ♦	14	35	83
18mm Shanks - D2			
SARM-180-3 ♦	18	45	92

♦ WHILE SUPPLIES LAST - Discontinued

SALM 3 FLUTE Catalog No.	Cutter Diameter (D1) mm	Effective Length Of Cut (L2) mm	Overall Length (L1) mm
6mm Shanks - D2			
SALM-060-3 ♦	6	25	75
8mm Shanks - D2			
SALM-080-3 ♦	8	30	75
12mm Shanks - D2			
SALM-120-3 ♦	12	50	100
16mm Shanks - D2			
SALM-160-3 ♦	16	75	150

J

For current pricing and availability please visit our website at www.micro100.com

FEATURING:

- Engineered with multiple corner radii per cutting diameter and a special 4-flute geometry, these high tech end mills are designed for hard material milling applications
- The various corner radii reduce cutting forces on the tip of the cutting edge and therefore support heavier cuts and longer tool life.
- Unique tool geometry provides maximum milling performance in semi-finishing and finishing as well as in rough cuts.



Tolerances (mm):
 Shank Diameter: -.0025-.0076
 Cutter Diameter: h8
 T.I.R. MAX: .013

Page 274
 for Coating
 Info

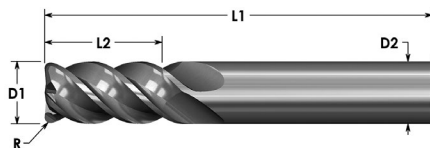

End Mills Coated with:

AITIN

HMCM 4 FLUTE Catalog No.	Cutter Diameter (D1) mm	Flute Length (L2) mm	Corner Radius (R) mm	Overall Length (L1) mm
6mm Shanks - D2				
HMCM-0302-4X	3	8	0.2	57
HMCM-0305-4X	3	8	0.5	57
HMCM-0402-4X	4	11	0.2	57
HMCM-0405-4X	4	11	0.5	57
HMCM-0410-4X	4	11	1.0	57
HMCM-0505-4X ♦	5	13	0.5	57
HMCM-0510-4X	5	13	1.0	57
HMCM-0603-4X ♦	6	13	0.3	57
HMCM-0605-4X	6	13	0.5	57
HMCM-0610-4X	6	13	1.0	57
8mm Shanks - D2				
HMCM-0803-4X	8	19	0.3	75
HMCM-0805-4X	8	19	0.5	75
HMCM-0810-4X ♦	8	19	1.0	75
HMCM-0815-4X ♦	8	19	1.5	75
10mm Shanks - D2				
HMCM-1005-4X	10	22	0.5	80
HMCM-1020-4X ♦	10	22	1.0	80
12mm Shanks - D2				
HMCM-1205-4X ♦	12	26	0.5	100
HMCM-1210-4X ♦	12	26	0.5	100
HMCM-1220-4X ♦	12	26	2.0	100
16mm Shanks - D2				
HMCM-1605-4X	16	32	1.0	110
HMCM-1620-4X ♦	16	32	2.0	110
20mm Shanks - D2				
HMCM-2010-4X ♦	20	38	1.0	125
HMCM-2015-4X ♦	20	38	1.5	125
HMCM-2020-4X ♦	20	38	2.0	125
HMCM-2030-4X ♦	20	38	3.0	125

♦ WHILE SUPPLIES LAST - Discontinued

FEATURING:

- Stub Length
- Variable Pitch
- High-Production / High Speed Milling
- Excellent Surface Finish
- Eliminates Chatter
- Reduces Machine Vibration

Page 274
for Coating
Info

THE V-HEMOTH
HIGH VELOCITY VARIABLE HELIX

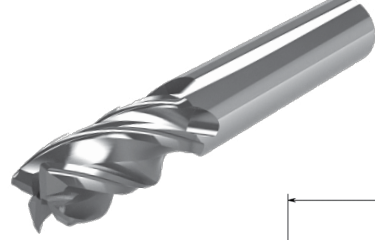

Tolerances (mm):
Shank Diameter: -.0025-.0076
Cutter Diameter: h9
Corner Radius: ±.013
T.I.R. MAX: .013



Weld on Flat ground on 10mm and larger shanks

Flutes Offset for Vibration Reduction

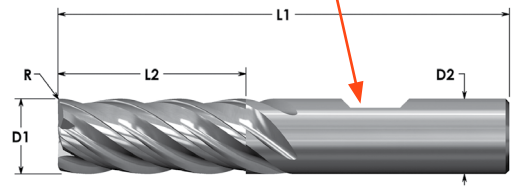

End Mills Coated with:
AITiN

VHSM 4 FLUTE Catalog No.	Cutter Diameter (D1) mm	Flute Length (L2) mm	Corner Radius (R) mm	Overall Length (L1) mm
4mm Shanks - D2				
VHSM-030-4X	3	6	0.5	50
VHSM-040-4X	4	8	0.5	50
6mm Shanks - D2				
VHSM-060-4X	6	10	0.5	57
8mm Shanks - D2				
VHSM-080-4X	8	16	0.5	63
10mm Shanks - D2				
VHSM-100-4X	10	19	0.5	72
12mm Shanks - D2				
VHSM-120-4X	12	22	0.5	83

End Mills Coated with
nACRo® (Nanotech "CR")

VHSM 5 FLUTE Catalog No.	Cutter Diameter (D1) mm	Flute Length (L2) mm	Corner Radius (R) mm	Overall Length (L1) mm
4mm Shanks - D2				
VHSM-030-5K	3	6	0.3	50
VHSM-040-5K	4	8	0.3	50
6mm Shanks - D2				
VHSM-060-5K	6	10	0.5	57
8mm Shanks - D2				
VHSM-080-5K	8	16	0.5	63
10mm Shanks - D2				
VHSM-100-5K	10	19	0.5	72
12mm Shanks - D2				
VHSM-120-5K	12	22	0.5	83

FEATURING:

- Designed and engineered to generate maximum metal removal rates in most applications.

THE SHREDDER

Tolerances (mm):
Shank Diameter: -.0025-.0076
Cutter Diameter: h9
T.I.R. MAX: .013

Page 274
for Coating
Info

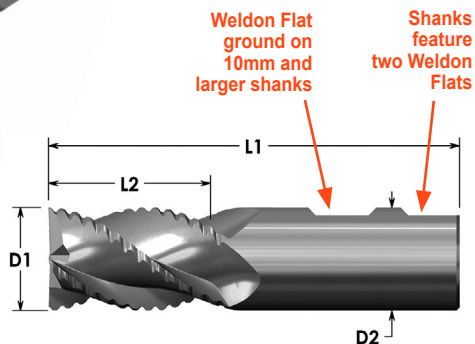

End Mills Coated with:

AlTiN

SHRM	Cutter Diameter (D1)	Flute Length (L2)	Overall Length (L1)
4 FLUTE Catalog No.	mm	mm	mm
6mm Shanks - D2			
SHRM-060-4X	6	16	57
8mm Shanks - D2			
SHRM-080-4X	8	22	63
10mm Shanks - D2			
SHRM-100-4X	10	25	72
12mm Shanks - D2			
SHRM-120-4X	12	30	83
16mm Shanks - D2			
SHRM-160-4X	16	35	92
20mm Shanks - D2			
SHRM-200-4X	20	45	104
25mm Shanks - D2			
SHRM-250-4X ♦	25	50	127

SHLM	Cutter Diameter (D1)	Flute Length (L2)	Overall Length (L1)
4 FLUTE Catalog No.	mm	mm	mm
6mm Shanks - D2			
SHLM-060-4X	6	25	75
8mm Shanks - D2			
SHLM-080-4X	8	30	75
10mm Shanks - D2			
SHLM-100-4X	10	38	100
12mm Shanks - D2			
SHLM-120-4X	12	50	100
16mm Shanks - D2			
SHLM-160-4X	16	75	150
18mm Shanks - D2			
SHLM-180-4X ♦	18	75	150
20mm Shanks - D2			
SHLM-200-4X	20	75	150

♦ WHILE SUPPLIES LAST - Discontinued

For current pricing and availability please visit our website at www.micro100.com

FEATURING:

- Variable Pitch
- High-Production / High Speed Milling
- Excellent Surface Finish
- Eliminates Chatter
- Reduces Machine Vibration

Page 274
for Coating
Info

THE V-HEMOTH
HIGH VELOCITY VARIABLE HELIX

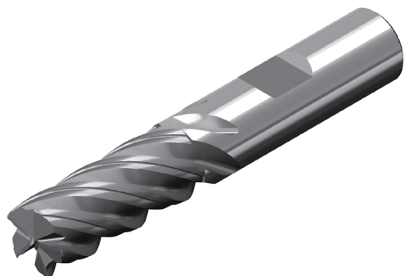

Tolerances (mm):
Shank Diameter: -.0025-.0076
Cutter Diameter:
4: +.000-.050
6-25: +.000-.080
Corner Radius: ±.013
T.I.R. MAX: .013



Flutes Offset for
Vibration Reduction

Weldon Flat
ground on
10mm and
larger shanks

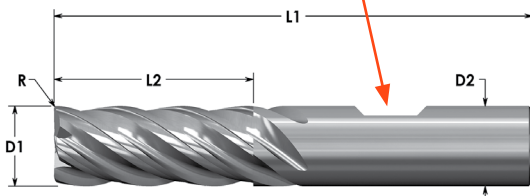

End Mills Coated with:

AlTiN

VHMM	Cutter Diameter (D1)	Flute Length (L2)	Corner Radius (R)	Overall Length (L1)
4 FLUTE Catalog No.	mm	mm	mm	mm
4mm Shanks - D2				
VHMM-030-4X	3	6	0.5	50
VHMM-040-4X	4	11	0.5	50
6mm Shanks - D2				
VHMM-050-4X	5	16	0.5	57
VHMM-060-4X	6	16	0.5	57
8mm Shanks - D2				
VHMM-080-4X	8	19	0.5	63
10mm Shanks - D2				
VHMM-100-4X	10	22	0.6	72
12mm Shanks - D2				
VHMM-120-4X	12	26	0.6	83
14mm Shanks - D2				
VHMM-140-4X ♦	14	26	0.7	83
18mm Shanks - D2				
VHMM-180-4X ♦	18	32	0.7	92
20mm Shanks - D2				
VHMM-200-4X ♦	20	38	0.8	104
25mm Shanks - D2				
VHMM-250-4X ♦	25	38	0.8	127

♦ WHILE SUPPLIES LAST - Discontinued

FEATURING:

- Variable Pitch
- High-Production / High Speed Milling
- Excellent Surface Finish
- Eliminates Chatter
- Reduces Machine Vibration

THE V-HEMOTH
HIGH VELOCITY VARIABLE HELIX

Tolerances (mm):
Shank Diameter: -.0025-.0076
Cutter Diameter: h9
Corner Radius: ±.013
T.I.R. MAX: .013



Flutes Offset for Vibration Reduction

Page 274
for Coating
Info



Weldon Flat ground on 10mm and larger shanks

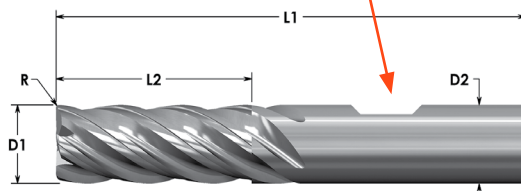

End Mills Coated with
nACro®
(Nanotech "CR")

VHMM	Cutter Diameter (D1)	Flute Length (L2)	Corner Radius (R)	Overall Length (L1)
5 FLUTE Catalog No.	mm	mm	mm	mm
4mm Shanks - D2				
VHMM-030-5K	3	8	0.3	50
VHMM-040-5K	4	11	0.3	50
6mm Shanks - D2				
VHMM-050-5K ♦	5	16	0.5	57
VHMM-060-5K	6	16	0.5	57
8mm Shanks - D2				
VHMM-080-5K	8	19	0.5	63
10mm Shanks - D2				
VHMM-100-5K	10	22	0.5	72
12mm Shanks - D2				
VHMM-120-5K	12	26	0.5	83

♦ WHILE SUPPLIES LAST - Discontinued

For current pricing and availability please visit our website at www.micro100.com

VLRM

4 Flute, Variable Helix High Velocity
Reduced Neck, Long Reach
End Mills - Metric

MICRO 100®
super carbide tools

FEATURING:

- Variable Pitch
- High-Production / High Speed Milling
- Reduced Neck for Greater Clearance
- Excellent Surface Finish
- Eliminates Chatter
- Reduces Machine Vibration

**Page 274
for Coating
Info**

**THE
V-HEMOTH
HIGH VELOCITY VARIABLE HELIX**

Tolerances (mm):
Shank Diameter: -.0025-.0076
Cutter Diameter:
4: +.000-.050
6-25: +.000-.080
Corner Radius: ±.013
T.I.R. MAX: .013

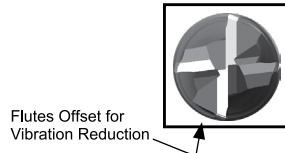
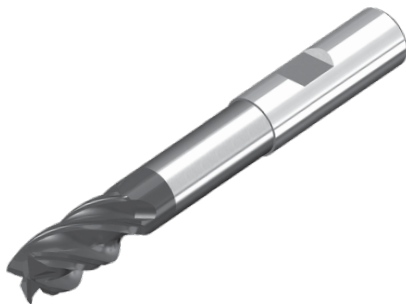

Weldon Flat ground on 10mm and larger shanks

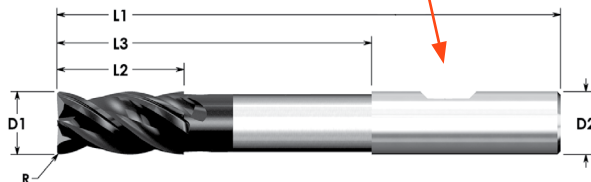

End Mills Coated with:

AlTiN

VLRM	Cutter Diameter (D1)	Flute Length (L2)	Corner Radius (R)	Overall Reach (L3)	Overall Length (L1)
4 FLUTE Catalog No.	mm	mm	mm	mm	mm
6mm Shanks - D2					
VLRM-040-4X	4	5	0.5	15	57
VLRM-060-4X	6	8	0.5	30	75
8mm Shanks - D2					
VLRM-080-4X	8	10	0.5	50	100
10mm Shanks - D2					
VLRM-100-4X ♦	10	12	0.6	50	100
14mm Shanks - D2					
VLRM-140-4X ♦	14	18	0.7	65	120
16mm Shanks - D2					
VLRM-160-4X ♦	16	22	0.7	80	130

♦ WHILE SUPPLIES LAST - Discontinued

J

For current pricing and availability please visit our website at www.micro100.com

FEATURING:

- These 5 flute high tech end mills feature a 45° Helix for roughing, finishing, and slotting in medium to hard steels, stainless steels, and high temperature alloys.
- Ideal for continuous full depth milling.
- Higher metal removal rates as well as excellent finishes are achieved with these 5 flute end mills.
- 45° Helix diminishes chatter corner milling application.

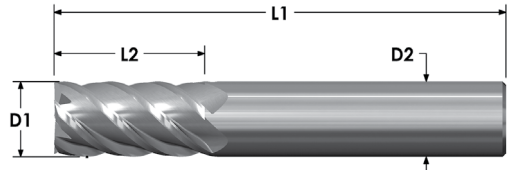

Tolerances (mm):
Shank Diameter: -.0025-.0076
Cutter Diameter: h9
T.I.R. MAX: .013

Page 274
for Coating
Info

AITiN – Add “X” to the end of Catalog No.

ALMM Catalog No.	Cutter Diameter (D1)	Flute Length (L2)	Overall Length (L1)
	mm	mm	mm
6mm Shanks - D2			
ALMM-030-5 ♦	3	25	75
ALMM-040-5 ♦	4	25	75
ALMM-050-5 ♦	5	25	75
10mm Shanks - D2			
ALMM-100-5 ♦	10	38	100
12mm Shanks - D2			
ALMM-120-5 ♦	12	50	100

♦ WHILE SUPPLIES LAST - Discontinued



For current pricing and availability please visit our website at www.micro100.com

AELM

2 & 4 Flute, Center Cutting,
30° Helix, Extra Long Length End Mills
- Metric

MICRO 100®
super carbide tools

Tolerances (mm):
Shank Diameter: -.0025-.0076
Cutter Diameter: h9
T.I.R. MAX: .013

Page 274
for Coating
Info

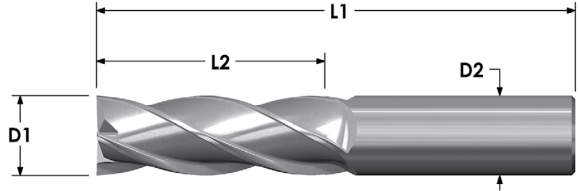
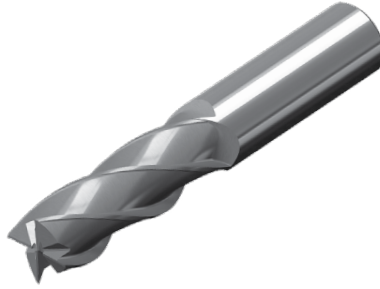

AITiN – Add “X” to the end of Catalog No.

AELM		Cutter Diameter (D1)	Flute Length (L2)	Overall Length (L1)
2 FLUTE Catalog No.	4 FLUTE Catalog No.			
		mm	mm	mm
6mm Shanks - D2				
AELM-020-2	AELM-020-4	2	10	75
AELM-030-2	AELM-030-4	3	15	75
AELM-040-2	AELM-040-4	4	20	75
-	AELM-050-4	5	25	100
AELM-060-2	AELM-060-4	6	30	100
-	AELM-070-4	7	35	100
8mm Shanks - D2				
AELM-080-2	AELM-080-4 ♦	8	40	100
10mm Shanks - D2				
AELM-100-2	AELM-100-4	10	50	120
AELM-110-2 ♦	AELM-110-4 ♦	11	50	120
12mm Shanks - D2				
-	AELM-120-4	12	55	130
AELM-140-2 ♦	-	14	60	140
16mm Shanks - D2				
-	AELM-160-4	16	65	150
20mm Shanks - D2				
AELM-200-2 ♦	AELM-200-4	20	75	150

♦ WHILE SUPPLIES LAST - Discontinued

For current pricing and availability please visit our website at www.micro100.com

Tolerances (mm):
Shank Diameter: -.0025-.0076
Cutter Diameter:
+.000-.076
Tool Radius:
+.000-.013

Page 274
for Coating
Info

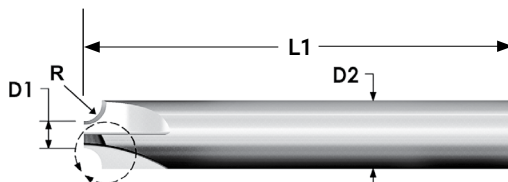
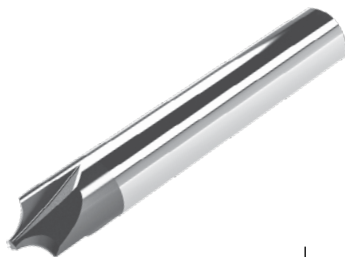

AITiN – Add “X” to the end of Catalog No.

CREM	Minor Diameter (D1)	Radius (R)	Overall Length (L1)
3 FLUTE			
Catalog No.	mm	mm	mm
6mm Shanks - D2			
CREM-060-030	1.5	0.30	57
CREM-060-050	1.5	0.50	57
CREM-060-080	1.5	0.80	57
CREM-060-100	1.5	1.00	57
CREM-060-125 ♦	1.5	1.25	57
CREM-060-150	1.5	1.50	57
CREM-060-200	1.5	2.00	57
8mm Shanks - D2			
CREM-080-250	1.5	2.50	63
CREM-080-300	1.5	3.00	63
10mm Shanks - D2			
CREM-100-350 ♦	1.5	3.50	73
CREM-100-400	1.5	4.00	73
12mm Shanks - D2			
CREM-120-450 ♦	1.5	5.00	83
CREM-120-500	1.5	5.00	83
18mm Shanks - D2			
CREM-180-700 ♦	3	7.00	92
20mm Shanks - D2			
CREM-200-800 ♦	3	8.00	104

♦ WHILE SUPPLIES LAST - Discontinued

For current pricing and availability please visit our website at www.micro100.com

DMM
2 & 4 Flute, 90° & 120° Included
Point Angle, Drill Mills
- Metric



Tolerances (mm):
 Shank Diameter: -.0025-.0076
 Cutter Diameter: h9
 T.I.R. MAX: .013



FEATURING:
 • Multi-purpose Drill-Mills for:
 Drilling
 Milling
 Chamfering
 Countersinking

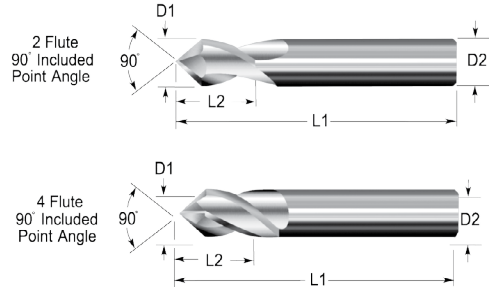
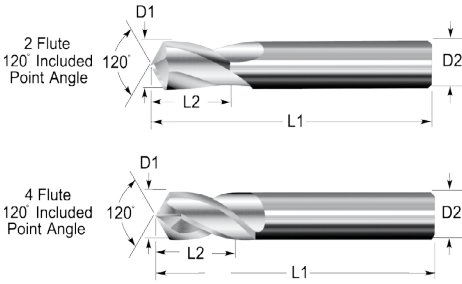

AITiN – Add “X” to the end of Catalog No.

DMM				Cutter Diameter (D1) mm	Flute Length (L2) mm	Overall Length (L1) mm
2 FLUTE 90° Catalog No.	4 FLUTE 90° Catalog No.	2 FLUTE 120° Catalog No.	4 FLUTE 120° Catalog No.			
3mm Shanks - D2						
DMM-030-290	DMM-030-490	DMM-030-2120	DMM-030-4120	3	8	38
4mm Shanks - D2						
DMM-040-290	DMM-040-490	DMM-040-2120	DMM-040-4120	4	11	50
6mm Shanks - D2						
DMM-050-290	DMM-050-490 ♦	DMM-050-2120	DMM-050-4120 ♦	5	13	57
DMM-060-290	DMM-060-490	DMM-060-2120	DMM-060-4120 ♦	6	16	57
8mm Shanks - D2						
DMM-080-290	DMM-080-490	DMM-080-2120	DMM-080-4120	8	22	63
10mm Shanks - D2						
DMM-100-290	DMM-100-490	DMM-100-2120	DMM-100-4120 ♦	10	25	72
12mm Shanks - D2						
DMM-120-290	DMM-120-490	DMM-120-2120	DMM-120-4120 ♦	12	30	83
16mm Shanks - D2						
DMM-160-290 ♦	DMM-160-490 ♦	DMM-160-2120 ♦	DMM-160-4120 ♦	16	35	92
18mm Shanks - D2						
-	-	-	DMM-180-4120 ♦	18	45	92
20mm Shanks - D2						
DMM-200-290 ♦	DMM-200-490 ♦	-	-	20	45	104

♦ WHILE SUPPLIES LAST - Discontinued

For current pricing and availability please visit our website at www.micro100.com

Tolerances (mm):
Shank Diameter: -.0025-.0076
Cutter Diameter: h9
T.I.R. MAX: .013

Page 274
for Coating
Info

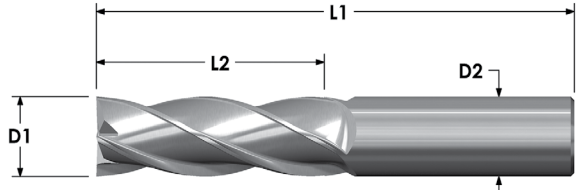
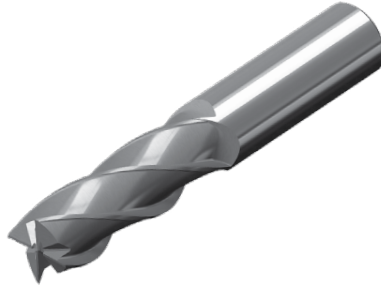

AITin – Add “X” to the end of Catalog No.

GELM			Cutter Diameter (D1)	Flute Length (L2)	Overall Length (L1)
2 FLUTE Catalog No.	3 FLUTE Catalog No.	4 FLUTE Catalog No.	mm	mm	mm
3mm Shanks - D2					
GELM-030-2	GELM-030-3	GELM-030-4	3	25	75
4mm Shanks - D2					
GELM-040-2	GELM-040-3	GELM-040-4	4	25	75
5mm Shanks - D2					
-	GELM-050-3 ♦	GELM-050-4 ♦	5	25	75
6mm Shanks - D2					
GELM-060-2	GELM-060-3	GELM-060-4	6	25	75
8mm Shanks - D2					
GELM-080-2 ♦	GELM-080-3	-	8	30	100
10mm Shanks - D2					
GELM-100-2 ♦	GELM-100-3	-	10	38	120
12mm Shanks - D2					
GELM-120-2 ♦	GELM-120-3 ♦	-	12	50	100
14mm Shanks - D2					
GELM-140-2 ♦	GELM-140-3 ♦	GELM-140-4 ♦	14	75	150
16mm Shanks - D2					
-	-	GELM-160-4 ♦	16	75	150
18mm Shanks - D2					
GELM-180-2 ♦	GELM-180-3 ♦	GELM-180-4 ♦	18	75	150
25mm Shanks - D2					
GELM-250-2 ♦	GELM-250-3 ♦	GELM-250-4 ♦	25	75	150

♦ WHILE SUPPLIES LAST - Discontinued

J

BEFM
 2 Flute, Extra Fine Carbide
 Reduced Neck, Hard Milling,
 Miniature Ball Nose End Mills - Metric



FEATURING:

- These precision miniature ball nose end mills are highly wear resistant and are ideal for finishing, and semi-finishing cuts, and universal milling applications in soft, medium to hard materials.
- Machine Hardened Materials 45-68 Rc
- Extra Fine Carbide End Mills Engineered for Hard Milling Applications.

Page 274
 for Coating
 Info

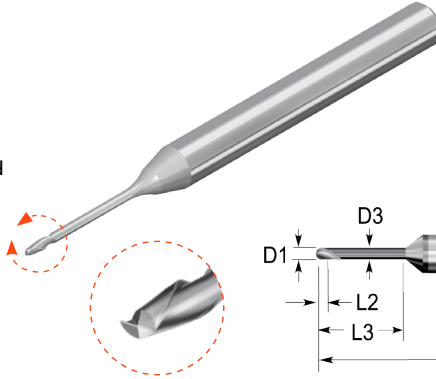

Tolerances (mm):
 Shank Diameter: -.0025-.0076
 Cutter Diameter: +.000-.0127
 T.I.R. MAX: .013
Longer necks are reduced neck

End Mills Coated with
nACRo[®]
 (Nanotech "CR")

BEFM		Cutter Diameter (D1)	Length of Cut (L2)	Overall Reach (L3)	Neck Diameter (D3)	Overall Length (L1)
2 FLUTE Catalog No.						
Uncoated	Coated	mm	mm	mm	mm	mm
6mm Shanks - D2						
BEFM-002-030	BEFM-002-030K	0.2	0.3	0.3	0.2	38
BEFM-003-045	BEFM-003-045K	0.3	0.45	0.45	0.3	38
BEFM-004-060	BEFM-004-060K	0.4	0.6	0.6	0.4	38
BEFM-005-070	BEFM-005-070K	0.5	0.7	0.7	0.45	38
BEFM-005-300	BEFM-005-300K	0.5	0.7	3.0	0.45	38
BEFM-005-600	BEFM-005-600K	0.5	0.7	6.0	0.45	38
BEFM-006-090	BEFM-006-090K	0.6	0.9	0.9	0.6	38
BEFM-006-300	BEFM-006-300K	0.6	0.9	3.0	0.55	38
BEFM-006-500	BEFM-006-500K	0.6	0.9	5.0	0.55	38
BEFM-006-600	BEFM-006-600K	0.6	0.9	6.0	0.55	38
BEFM-008-120	BEFM-008-120K	0.8	1.2	1.2	0.8	38
BEFM-008-400	BEFM-008-400K	0.8	1.2	4.0	0.75	38
BEFM-008-700	BEFM-008-700K	0.8	1.2	7.0	0.75	38
BEFM-008-900	BEFM-008-900K	0.8	1.2	9.0	0.75	38
BEFM-010-150	BEFM-010-150K	1.0	1.5	1.5	1.00	38
BEFM-010-400	BEFM-010-400K	1.0	1.5	4.0	0.95	38
BEFM-010-700	BEFM-010-700K	1.0	1.5	7.0	0.95	38
BEFM-010-900	BEFM-010-900K	1.0	1.5	9.0	0.95	38
BEFM-012-180	BEFM-012-180K	1.2	1.8	1.8	1.20	38
BEFM-012-600	BEFM-012-600K	1.2	1.8	6.0	1.10	38
BEFM-012-1000	BEFM-012-1000K	1.2	1.8	10.0	1.10	38
BEFM-012-1200	BEFM-012-1200K	1.2	1.8	12.0	1.10	38
BEFM-015-220	BEFM-015-220K	1.5	2.2	2.2	1.50	38
BEFM-015-600	BEFM-015-600K	1.5	2.2	6.0	1.40	38
BEFM-015-1000	BEFM-015-1000K	1.5	2.2	10.0	1.40	38
BEFM-015-1200	BEFM-015-1200K	1.5	2.2	12.0	1.40	38
BEFM-015-1500	BEFM-015-1500K	1.5	2.2	15.0	1.40	38
BEFM-015-2000	BEFM-015-2000K	1.5	2.2	20.0	1.40	50

For current pricing and availability please visit our website at www.micro100.com

FEATURING:

- These precision miniature ball nose end mills are highly wear resistant and are ideal for finishing, and semi-finishing cuts, and universal milling applications in soft, medium to hard materials.
- Machine Hardened Materials 45-68 Rc
- Extra Fine Carbide End Mills Engineered for Hard Milling Applications.

Tolerances (mm):
 Shank Diameter: -.0025-.0076
 Cutter Diameter: +.000-.0127
 T.I.R. MAX: .013
Longer necks are reduced neck

Page 274
for Coating
Info

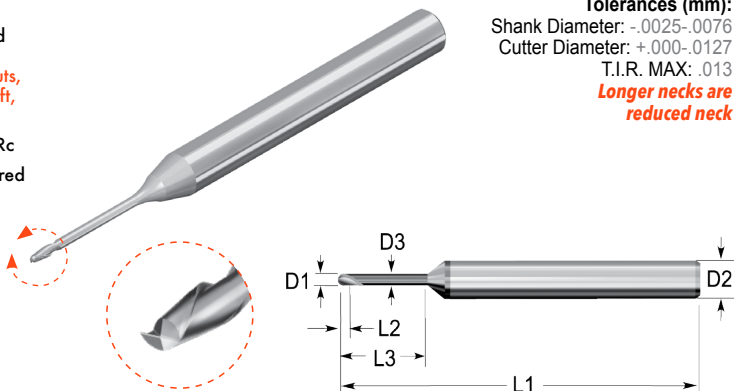

End Mills Coated with
nACRo[®]
(Nanotech "CR")

BEFM		Cutter Diameter (D1)	Length of Cut (L2)	Overall Reach (L3)	Neck Diameter (D3)	Overall Length (L1)
2 FLUTE Catalog No.						
Uncoated	Coated	mm	mm	mm	mm	mm
3mm Shanks - D2						
BEFM-020-250	BEFM-020-250K	2.0	2.5	2.5	2.0	38
BEFM-020-700	BEFM-020-700K	2.0	2.5	7.0	1.9	38
BEFM-020-1200	BEFM-020-1200K	2.0	2.5	12.0	1.9	38
BEFM-020-1600	BEFM-020-1600K	2.0	2.5	16.0	1.9	38
BEFM-020-2000	BEFM-020-2000K	2.0	2.5	20.0	1.9	50
BEFM-020-2500	BEFM-020-2500K	2.0	2.5	25.0	1.9	50
BEFM-025-300	BEFM-025-300K	2.5	3.0	3.0	2.5	32
BEFM-025-1000	BEFM-025-1000K	2.5	3.0	10.0	2.4	38
BEFM-025-1500	BEFM-025-1500K	2.5	3.0	15.0	2.4	38
BEFM-025-2000	BEFM-025-2000K	2.5	3.0	20.0	2.4	50
BEFM-025-2500	BEFM-025-2500K	2.5	3.0	25.0	2.4	50
BEFM-025-3000	BEFM-025-3000K	2.5	3.0	30.0	2.4	60
6mm Shanks - D2						
BEFM-030-300	BEFM-030-300K	3.0	3.0	3.0	3.0	57
BEFM-030-1000	BEFM-030-1000K	3.0	3.0	10.0	2.9	57
BEFM-030-1500	BEFM-030-1500K	3.0	3.0	15.0	2.9	57
BEFM-030-2500	BEFM-030-2500K	3.0	3.0	25.0	2.9	57
BEFM-030-3000	BEFM-030-3000K	3.0	3.0	30.0	2.9	57
BEFM-040-500	BEFM-040-500K	4.0	5.0	5.0	4.0	57
BEFM-040-1500	BEFM-040-1500K	4.0	5.0	15.0	3.9	57
BEFM-040-2500	BEFM-040-2500K	4.0	5.0	25.0	3.9	57
BEFM-040-3000	BEFM-040-3000K	4.0	5.0	30.0	3.9	57
BEFM-050-600	BEFM-050-600K	5.0	6.0	6.0	5.0	57
BEFM-050-1500	BEFM-050-1500K	5.0	6.0	15.0	4.9	57
BEFM-050-2500	BEFM-050-2500K	5.0	6.0	25.0	4.9	57
BEFM-050-3000	BEFM-050-3000K	5.0	6.0	30.0	4.9	57

For current pricing and availability please visit our website at www.micro100.com

SFBM

2 Flute, Center Cutting, 30° Helix
HSC Shrink Fit, Ball Nose
End Mills - Metric



FEATURING:

- These high precision ball nose end mills feature multiple neck length dimensions in a wide range of cutting diameters to provide the best available geometry for finishing cuts in mold making applications.
- A positive rake angle supports maximum cutting performance in medium and hard materials for conventional side milling and slotting.

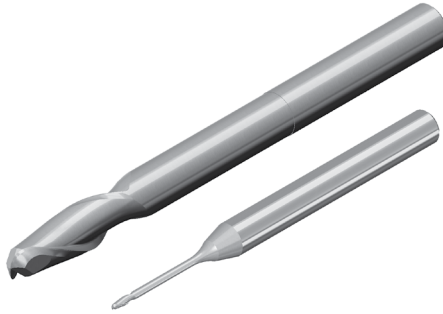

Tolerances (mm):
Shank Diameter: -.0025-.0076
Cutter Diameter: h8
T.I.R. MAX: .013

Page 274
for Coating
Info

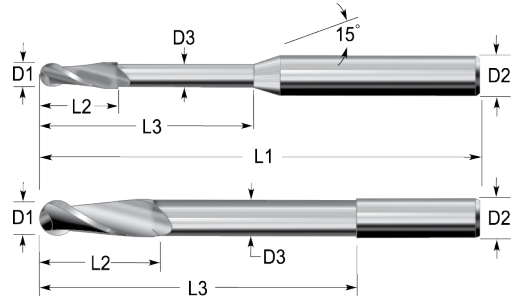

AITiN – Add “X” to the end of Catalog No.

SFBM	Cutter Diameter (D1)	Flute Length (L2)	Reduced Neck Diameter (D3)	Overall Reach (L3)	Overall Length (L1)
2 FLUTE Catalog No.	mm	mm	mm	mm	mm
6mm Shanks - D2					
SFBM-002-0	0.2	0.3	N/A	N/A	57
SFBM-003-0 ♦	0.3	0.4	N/A	N/A	57
SFBM-003-1	0.3	0.4	0.25	1.0	57
SFBM-004-1 ♦	0.4	0.5	0.35	1.2	57
SFBM-005-1	0.5	0.6	0.45	1.6	57
SFBM-005-3 ♦	0.5	0.5	0.45	3.3	57
SFBM-008-2 ♦	0.8	1.0	0.75	2.5	57
SFBM-008-5	0.8	0.8	0.75	5.2	57
SFBM-008-8	0.8	0.8	0.75	8.0	57
SFBM-010-3	1.0	1.3	0.95	3.3	57
SFBM-012-3 ♦	1.2	1.5	1.15	3.5	57
SFBM-012-8 ♦	1.2	1.2	1.15	8.0	57
SFBM-015-9	1.5	1.5	1.45	9.5	57
SFBM-020-9	2.0	2.5	1.95	9.5	57
SFBM-030-8	3.0	4.0	2.90	8.0	57
SFBM-030-15	3.0	4.0	2.90	15.0	57
SFBM-040-20	4.0	5.0	3.90	20.0	57
SFBM-050-11	5.0	6.0	4.90	11.0	57
SFBM-060-12	6.0	7.5	5.90	12.5	57
SFBM-060-25	6.0	7.5	5.90	25.0	57

♦ WHILE SUPPLIES LAST - Discontinued

J

Tolerances (mm):
Shank Diameter: -.0025-.0076
Cutter Diameter: h9
T.I.R. MAX: .013

Page 274
for Coating
Info

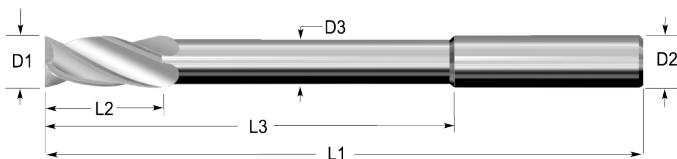

AITIN – Add “X” to the end of Catalog No.

GLRM		Cutter Diameter (D1)	Flute Length (L2)	Reduced Neck Diameter (D3)	Overall Reach (L3)	Overall Length (L1)
2 FLUTE Catalog No.	4 FLUTE Catalog No.					
		mm	mm	mm	mm	mm
6mm Shanks - D2						
GLRM-020-2	GLRM-020-4	2	5	1.5	15	57
GLRM-030-2	GLRM-030-4	3	8	2.5	30	75
GLRM-040-2	GLRM-040-4	4	8	3.5	30	75
GLRM-050-2	GLRM-050-4	5	10	4.5	50	100
GLRM-060-2	GLRM-060-4	6	12	5.5	50	100
8mm Shanks - D2						
-	GLRM-080-4	8	14	7.5	50	100
10mm Shanks - D2						
GLRM-100-2	GLRM-100-4	10	18	9.5	65	120
12mm Shanks - D2						
GLRM-120-2	GLRM-120-4	12	22	11.5	80	130
16mm Shanks - D2						
GLRM-160-2 ♦	-	16	30	15.5	100	150

♦ WHILE SUPPLIES LAST - Discontinued

J

For current pricing and availability please visit our website at www.micro100.com

MMBM

2 Flute, Center Cutting, 30° Helix Mold Making, Reduced Neck Ball Nose End Mills - Metric

MICRO 100®
super carbide tools

FEATURING:

- These high precision ball nose end mills feature multiple neck length dimensions in a wide range of cutting diameters to provide the best available geometry for finishing cuts in mold making applications.
- A positive rake angle supports maximum cutting performance in medium and hard materials for conventional side milling and slotting.

Tolerances (mm):
Shank Diameter: -.0025-.0076
Cutter Diameter: h8
T.I.R. MAX: .013



**Page 274
for Coating
Info**

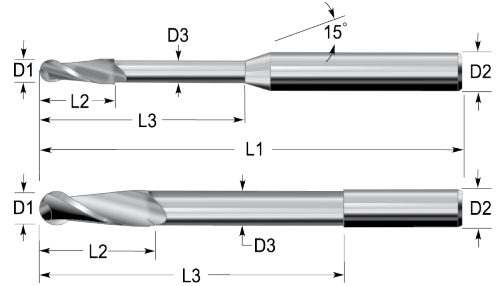

AITiN – Add “X” to the end of Catalog No.

MMBM	Cutter Diameter (D1)	Flute Length (L2)	Reduced Neck Diameter (D3)	Overall Reach (L3)	Overall Length (L1)
2 FLUTE Catalog No.	mm	mm	mm	mm	mm
4mm Shanks - D2					
MMBM-003-3	0.3	0.3	0.28	3	50
MMBM-003-6 ♦	0.3	0.3	0.28	6	50
MMBM-004-3	0.4	0.4	0.38	3	50
MMBM-004-8	0.4	0.4	0.38	8	50
MMBM-005-5	0.5	0.5	0.48	5	50
MMBM-005-10	0.5	0.5	0.48	10	50
MMBM-006-5	0.6	0.6	0.58	5	50
MMBM-006-12	0.6	0.6	0.58	12	50
MMBM-007-5	0.7	0.7	0.68	5	50
MMBM-008-5	0.8	0.8	0.78	5	50
MMBM-008-10	0.8	0.8	0.78	10	50
MMBM-008-16	0.8	0.8	0.78	16	50
MMBM-009-10 ♦	0.9	0.9	0.88	10	50

♦ WHILE SUPPLIES LAST - Discontinued

For current pricing and availability please visit our website at www.micro100.com

FEATURING:

- These high precision ball nose end mills feature multiple neck length dimensions in a wide range of cutting diameters to provide the best available geometry for finishing cuts in mold making applications.
- A positive rake angle supports maximum cutting performance in medium and hard materials for conventional side milling and slotting.

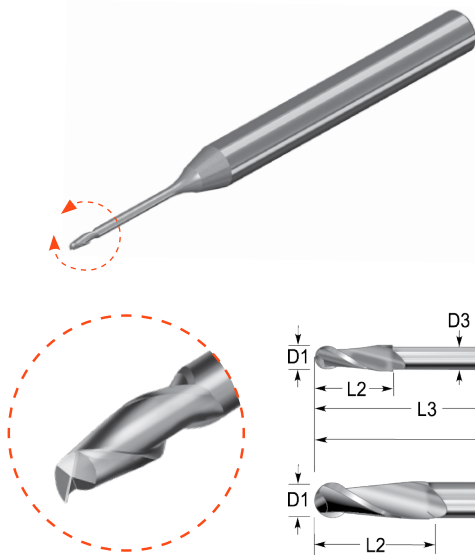

Tolerances (mm):
Shank Diameter: -.0025-.0076
Cutter Diameter: h8
T.I.R. MAX: .013

Page 274
for Coating
Info

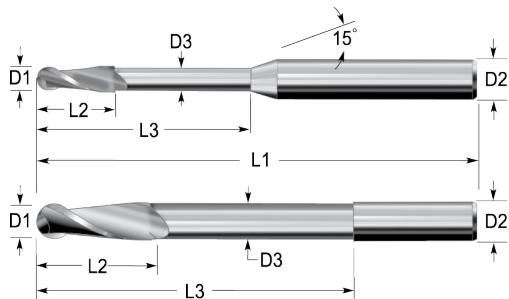

AITiN – Add “X” to the end of Catalog No.

MMBM	Cutter Diameter (D1)	Flute Length (L2)	Reduced Neck Diameter (D3)	Overall Reach (L3)	Overall Length (L1)
2 FLUTE	mm	mm	mm	mm	mm
Catalog No.	mm	mm	mm	mm	mm
6mm Shanks - D2					
MMBM-010-6	1.0	1.0	0.95	6	57
MMBM-010-8	1.0	1.0	0.95	8	57
MMBM-010-11	1.0	1.0	0.95	11	57
MMBM-010-12 ♦	1.0	1.0	0.95	12	57
MMBM-010-15	1.0	1.0	0.95	15	57
MMBM-010-20	1.0	1.0	0.95	20	57
MMBM-012-7	1.2	1.2	1.15	7	57
MMBM-012-15	1.2	1.2	1.15	15	57
MMBM-012-20 ♦	1.2	1.2	1.15	20	57
MMBM-015-7	1.5	1.5	1.45	7	57
MMBM-015-15	1.5	1.5	1.45	15	57
MMBM-015-20	1.5	1.5	1.45	20	57
MMBM-020-7	2.0	2.0	1.90	7	57
MMBM-020-15	2.0	2.0	1.90	15	57
MMBM-020-20	2.0	2.0	1.90	20	57
MMBM-030-12	3.0	3.0	2.90	12	57
MMBM-030-15	3.0	3.0	2.90	15	57
MMBM-040-15	4.0	4.0	3.80	15	57
MMBM-050-15	5.0	5.0	4.80	15	57

♦ WHILE SUPPLIES LAST - Discontinued

For current pricing and availability please visit our website at www.micro100.com

FEATURING:

- Variable Pitch
- High-Production / High Speed Milling
- Excellent Surface Finish
- Eliminates Chatter
- Reduced Machine Vibration

Page 274
for Coating
Info

**THE
V-HEMOTH
HIGH VELOCITY VARIABLE HELIX**

Tolerances (mm):
Shank Diameter: -.0025-.0076
Cutter Diameter: h9
T.I.R. MAX: .013

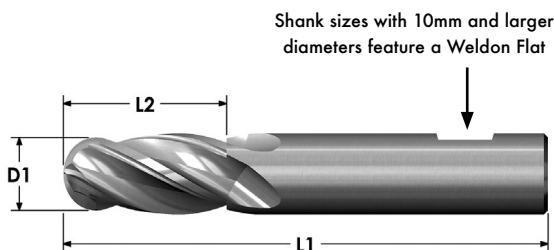

End Mills Coated with:

AlTiN

VHBM	Cutter Diameter (D1)	Flute Length (L2)	Overall Length (L1)
4 FLUTE Catalog No.	mm	mm	mm
12mm Shanks - D2			
VHBM-120-4X ♦	12	26	83
14mm Shanks - D2			
VHBM-140-4X ♦	14	26	83
16mm Shanks - D2			
VHBM-160-4X ♦	16	32	92

♦ WHILE SUPPLIES LAST - Discontinued

J

For current pricing and availability please visit our website at www.micro100.com

FEATURING:

- High performance ball nose end mills with a 2, 3 & 4 flute geometry and a helix of 30°.

These end mills are ideal for semi-finishing, finishing, and slotting in steels, stainless steels, high temperature alloys, and other difficult to machine materials.



Tolerances (mm):
Shank Diameter: -.0025-.0076
Cutter Diameter: h9
T.I.R. MAX: .013

Page 274
for Coating
Info

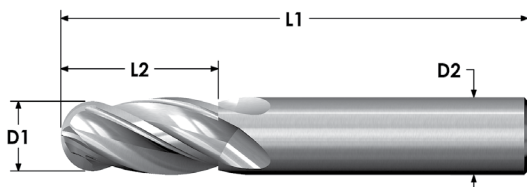

AITiN – Add “X” to the end of Catalog No.

BEMM			Cutter Diameter (D1)	Flute Length (L2)	Overall Length (L1)
2 FLUTE Catalog No.	3 FLUTE Catalog No.	4 FLUTE Catalog No.			
			mm	mm	mm
3mm Shanks - D2					
BEMM-030-2	BEMM-030-3	BEMM-030-4	3	15	38
4mm Shanks - D2					
BEMM-040-2	BEMM-040-3	BEMM-040-4	4	18	50
6mm Shanks - D2					
-	BEMM-050-3 ♦	-	5	18	50
BEMM-060-2	BEMM-060-3 ♦	BEMM-060-4	6	18	57
8mm Shanks - D2					
BEMM-080-2	BEMM-080-3 ♦	BEMM-080-4	8	22	63
10mm Shanks - D2					
BEMM-100-2	BEMM-100-3	BEMM-100-4	10	25	72
12mm Shanks - D2					
-	BEMM-120-3 ♦	BEMM-120-4	12	30	83
16mm Shanks - D2					
-	BEMM-160-3 ♦	-	16	35	92
18mm Shanks - D2					
BEMM-180-2 ♦	-	BEMM-180-4 ♦	18	45	92
20mm Shanks - D2					
BEMM-200-2 ♦	BEMM-200-3 ♦	BEMM-200-4 ♦	20	45	104

♦ WHILE SUPPLIES LAST - Discontinued

For current pricing and availability please visit our website at www.micro100.com

FEATURING:

- These short flute 220° spherical ball nose end mills feature a reduced neck diameter and are ideal for copy milling and deep pocket milling applications.
- The special geometry allows inclination of up to 15° with optimal chip evacuation for increased feed rates.

Page 274
for Coating
Info

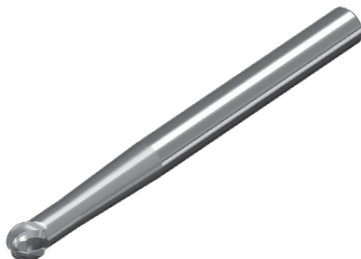

Tolerances (mm):
Shank Diameter: -.0025-.0076
Cutter Diameter:
2-6 +0/-0.051
8 & up: +0/-0.076
T.I.R. MAX: .013

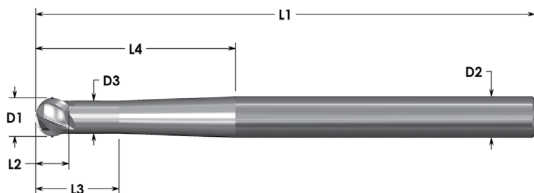

AiTIn – Add “X” to the end of Catalog No.

SBMM			Cutter Diameter (D1)	Flute Length (L2)	Neck Diameter (D3)	Neck Length (L3)	Overall Reach (L4)	Radius	Overall Length (L1)
2 FLUTE Catalog No.	3 FLUTE Catalog No.	4 FLUTE Catalog No.							
6mm Shanks - D2									
SBMM-020-206	–	SBMM-020-406	2	1.3	1.3	6	32	1.0	75
SBMM-020-210	–	SBMM-020-410	2	1.3	1.3	10	36	1.0	75
SBMM-020-216	SBMM-020-316	SBMM-020-416	2	1.3	1.3	16	42	1.0	75
SBMM-030-209	–	SBMM-030-409	3	2.0	2.0	9	31	1.5	75
SBMM-030-215	–	SBMM-030-415	3	2.0	2.0	15	37	1.5	75
SBMM-030-221	SBMM-030-321	SBMM-030-421	3	2.0	2.0	21	43	1.5	75
SBMM-040-212	–	SBMM-040-412	4	2.7	2.7	12	30	2.0	75
SBMM-040-220	–	SBMM-040-420	4	2.7	2.7	20	36	2.0	75
SBMM-040-232	–	SBMM-040-432	4	2.7	2.7	32	44	2.0	100
SBMM-060-218♦	SBMM-060-318♦	SBMM-060-418	6	4.0	4.0	18	29	3.0	75
SBMM-060-230	–	SBMM-060-430	6	4.0	4.0	30	41	3.0	75
SBMM-060-248♦	SBMM-060-348♦	SBMM-060-448	6	4.0	4.0	32	44	3.0	100
8mm Shanks - D2									
SBMM-080-224♦	SBMM-080-324♦	SBMM-080-424	8	5.4	5.4	24	39	4.0	100
SBMM-080-240♦	SBMM-080-340♦	SBMM-080-440	8	5.4	5.4	40	55	4.0	100
SBMM-080-264♦	–	SBMM-080-464	8	5.4	5.4	55	68	4.0	100
10mm Shanks - D2									
SBMM-100-230	–	SBMM-100-430	10	6.7	6.7	30	48	5.0	100
SBMM-100-250	–	SBMM-100-450	10	6.7	6.7	50	59	5.0	100
SBMM-100-272	–	SBMM-100-472	10	6.7	6.7	55	68	5.0	100
12mm Shanks - D2									
SBMM-120-236	–	SBMM-120-436	12	8.0	8.0	36	58	6.0	100
–	–	SBMM-120-472	12	8.0	8.0	55	68	6.0	100
16mm Shanks - D2									
SBMM-160-248♦	–	SBMM-160-448♦	16	10.7	10.7	48	55	8.0	100
–	–	SBMM-160-472♦	16	10.7	10.7	55	68	8.0	100

♦ WHILE SUPPLIES LAST - Discontinued

FEATURING:

- Engineered with a negative rake angle, these high-tech end mills are specifically engineered for numerous milling applications in hard materials.
- The unique tool geometry provides maximum milling performance in semi-finishing and finishing as well as roughing cuts.



Tolerances (mm):
Shank Diameter: -.0025-.0076
Cutter Diameter: h9
T.I.R. MAX: .013

Page 274
for Coating
Info

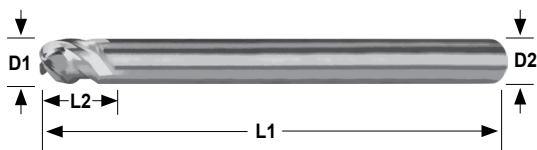

AITiN – Add “X” to the end of Catalog No.

HMBM		Cutter Diameter (D1) mm	Flute Length (L2) mm	Overall Length (L1) mm
2 FLUTE Catalog No.	4 FLUTE Catalog No.			
4mm Shanks - D2				
HMBM-010-2 ♦	–	1.0	1.5	50
6mm Shanks - D2				
HMBM-025-2 ♦	–	2.5	4.0	57
HMBM-050-2 ♦	–	5.0	7.5	80
HMBM-060-2 ♦	HMBM-060-4 ♦	6.0	9.0	90
8mm Shanks - D2				
HMBM-080-2 ♦	HMBM-060-4 ♦	8.0	12.0	100
10mm Shanks - D2				
HMBM-100-2 ♦	HMBM-100-4 ♦	10.0	15.0	100
12mm Shanks - D2				
HMBM-120-2 ♦	HMBM-120-4 ♦	12.0	18.0	110
16mm Shanks - D2				
HMBM-160-2 ♦	HMBM-160-4 ♦	16.0	24.0	140
20mm Shanks - D2				
HMBM-200-2 ♦	–	20.0	30.0	160

♦ WHILE SUPPLIES LAST - Discontinued

For current pricing and availability please visit our website at www.micro100.com

Tolerances (mm):
Shank Diameter: -.0025-.0076
Cutter Diameter: h9
T.I.R. MAX: .013

Page 274
for Coating
Info

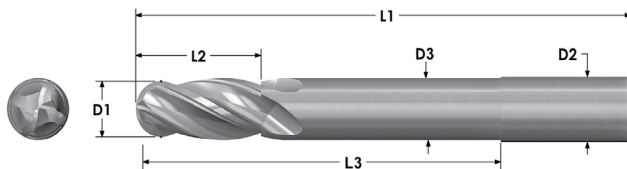

AITiN – Add “X” to the end of Catalog No.

BELM			Cutter Diameter (D1) mm	Flute Length (L2) mm	Overall Length (L1) mm
2 FLUTE Catalog No.	3 FLUTE Catalog No.	4 FLUTE Catalog No.			
3mm Shanks - D2					
BELM-030-2 ♦	BELM-030-3 ♦	BELM-030-4 ♦	3	25	75
5mm Shanks - D2					
BELM-050-2 ♦	–	–	5	25	75
6mm Shanks - D2					
BELM-060-2 ♦	–	BELM-060-4 ♦	6	25	75
8mm Shanks - D2					
BELM-080-2 ♦	BELM-080-3 ♦	–	8	25	75
10mm Shanks - D2					
BELM-100-2 ♦	BELM-100-3 ♦	BELM-100-4 ♦	10	38	100
12mm Shanks - D2					
BELM-120-2 ♦	BELM-120-3 ♦	BELM-120-4 ♦	12	50	100
14mm Shanks - D2					
BELM-140-2 ♦	BELM-140-3 ♦	BELM-140-4 ♦	14	75	150
16mm Shanks - D2					
–	BELM-160-3 ♦	BELM-160-4 ♦	16	75	150
18mm Shanks - D2					
BELM-180-2 ♦	BELM-180-3 ♦	BELM-180-4 ♦	18	75	150
20mm Shanks - D2					
BELM-200-2 ♦	BELM-200-3 ♦	BELM-200-4 ♦	20	75	150
25mm Shanks - D2					
BELM-250-2 ♦	BELM-250-3 ♦	BELM-250-4 ♦	25	75	150

♦ WHILE SUPPLIES LAST - Discontinued

For current pricing and availability please visit our website at www.micro100.com

Page 274
for Coating
Info



Tolerances (mm):
Shank Diameter: -.0025-.0076
Cutter Diameter: h9
T.I.R. MAX: .013

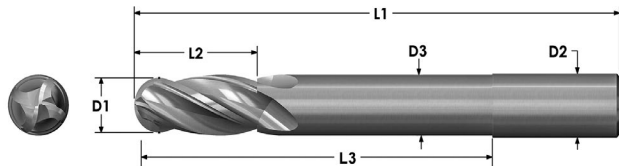

AITiN – Add “X” to the end of Catalog No.

BLRM			Cutter Diameter (D1)	Flute Length (L2)	Reduced Neck Diameter (D3)	Overall Reach (L3)	Overall Length (L1)
2 FLUTE Catalog No.	3 FLUTE Catalog No.	4 FLUTE Catalog No.					
6mm Shanks - D2							
BLRM-020-2	BLRM-020-3 ♦	BLRM-020-4	2	5	1.5	15	57
BLRM-030-2	BLRM-030-3 ♦	BLRM-030-4	3	8	2.5	30	75
BLRM-040-2	BLRM-040-3 ♦	BLRM-040-4	4	8	3.5	30	75
–	–	BLRM-050-4 ♦	5	10	4.5	50	100
BLRM-060-2	BLRM-060-3 ♦	BLRM-060-4	6	12	5.5	50	100
8mm Shanks - D2							
BLRM-080-2	BLRM-080-3 ♦	BLRM-080-4	8	14	7.5	50	100
10mm Shanks - D2							
BLRM-100-2	BLRM-100-3 ♦	BLRM-100-4	10	18	9.5	65	120
12mm Shanks - D2							
BLRM-120-2	BLRM-120-3 ♦	BLRM-120-4	12	22	11.5	80	130
16mm Shanks - D2							
BLRM-160-2 ♦	BLRM-160-3 ♦	BLRM-160-4 ♦	16	30	15.5	100	150
20mm Shanks - D2							
BLRM-200-2 ♦	BLRM-200-3 ♦	BLRM-200-4 ♦	20	38	19.5	100	150

♦ WHILE SUPPLIES LAST - Discontinued

For current pricing and availability please visit our website at www.micro100.com

FUN WITH TOOLS WORD PAGE

WORD SEARCH

Y D R I L L M I L L H L R F H
 E T U L F W B F G N X L W C M
 O T U Z B Y Q P R S A I K A Q
 A Y Y D X J D G O U L M K R O
 T H R E A D C R O S T D P B O
 O L F K C E E H V M I N J I I
 O T K V G F V P I V N E J D O
 L B P D M U X Z N P H H Y E R
 P Y U A F R A B G N I R O B C
 B L H G L N T V W G I B P V I
 S C C M N U G P J Q R P Y V M
 W E L D O N C R O U T E R R I
 Z G N I T A O C K X L V I E O
 C F S S S U T Q K E V F Q O Z
 B T J C O O L A N T M R J T C

ENDMILL COOLANT
 BORINGBAR SLUDGE
 FLUTE CHIP
 ROUTER CHAMFER
 TOOL DRILLMILL
 COATING GROOVING
 ALTIN THREAD
 CARBIDE WELDON
 MICRO100

CROSSWORD PUZZLE

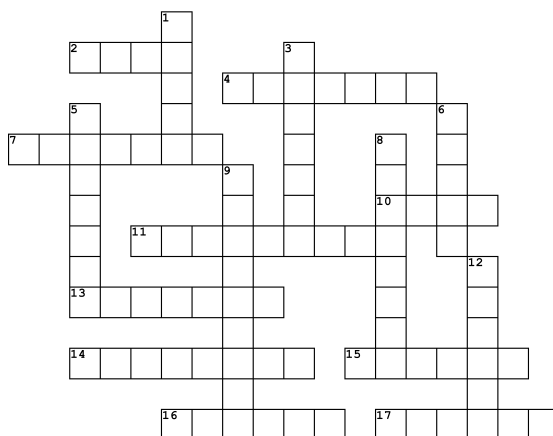

Across

2. Helps accomplishing a task
4. An ant that needs a heater
7. Cut made in material
10. Not the Doritos flying off your bits
11. Snoozing with a beer
13. Removes Material
14. What you do to 70's music
15. Sharpen your bit
16. 'very good'
17. Mudlike deposits

Down

1. Musical Instrument
3. Covers a surface
5. Hard stuff
6. Not TiN
8. Excellence in Carbide Prep
9. 2 or more cutting edges
12. Can go in the eye of a needle

*World Class Quality
Through Manufacturing Excellence*



*Combined with Superior Strength and
Wear Characteristics Providing Unmatched
High Performance Productivity at it's BEST!*



Half Round Blanks
Round Blanks
Split End Blanks



**WILL NOT CHIP OR BREAK
UNDER NORMAL MACHINING CONDITIONS**



Blanks

1 & 2 Split Ends

- Metric



Tolerances (mm):

Shank Diameter: $-.0025-.0076$

Split Tolerance: $+.038\text{mm}/-.762\text{mm}$

Overall Length: $\pm.38$

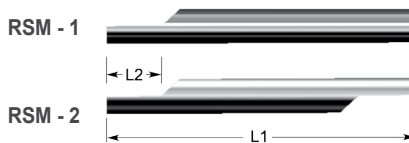
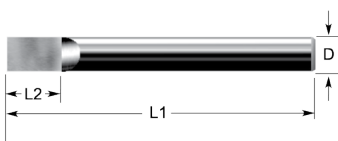

RSM	RSM	Split Length (L2)	Overall Length (L1)
Single End Catalog No.	Double End Catalog No.		
		mm	mm
2mm Shanks - D2			
RSM-020-1 ♦	RSM-020-2	4	38
3mm Shanks - D2			
-	RSM-030-2	5	38
4mm Shanks - D2			
RSM-040-1	RSM-040-2	6	50
5mm Shanks - D2			
-	RSM-050-2 ♦	7	50
6mm Shanks - D2			
RSM-060-1	RSM-060-2	8	57
8mm Shanks - D2			
RSM-080-1	RSM-080-2	10	63
10mm Shanks - D2			
RSM-100-1	RSM-100-2	12	72
12mm Shanks - D2			
-	RSM-120-2 ♦	14	83

♦ WHILE SUPPLIES LAST - Discontinued

K

For current pricing and availability please visit our website at www.micro100.com

Style "HRM" by SPECIAL ORDER once current inventories are depleted.

Tolerances (mm):
Shank Diameter: +0.01/0.0

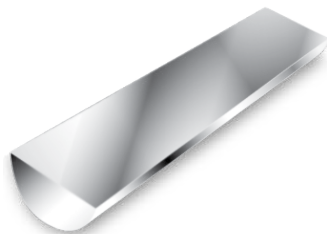

HRM Catalog No.	Cutter Diameter (D1) mm	Overall Length (L1) mm
2mm Shanks - D1		
HRM-020-38 ♦	1.0	38
3mm Shanks - D1		
HRM-030-38 ♦	1.5	38
4mm Shanks - D1		
HRM-040-50	2.0	50
5mm Shanks - D1		
HRM-050-50	2.5	50
6mm Shanks - D1		
HRM-060-57	3.0	57
8mm Shanks - D1		
HRM-080-63	4.0	63
10mm Shanks - D1		
HRM-100-72 ♦	5.0	72
12mm Shanks - D1		
HRM-120-83 ♦	6.0	83

♦ WHILE SUPPLIES LAST - Discontinued



For current pricing and availability please visit our website at www.micro100.com

Tolerances (mm):
 Shank Diameter:
 -.0025-.0076

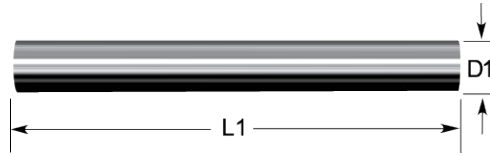

SRM Catalog No.	Overall Length (L1) mm
1mm Shanks - D1	
SRM-010-030	30
SRM-010-310	310
1.5mm Shanks - D1	
SRM-015-100	100
2mm Shanks - D1	
SRM-020-038	38
SRM-020-100	100
SRM-020-310	310
2.5mm Shanks - D1	
SRM-025-100	100
3mm Shanks - D1	
SRM-030-038	38
SRM-030-100	100
SRM-030-310	310
3.5mm Shanks - D1	
SRM-035-100	100
4mm Shanks - D1	
SRM-040-050	50
SRM-040-100	100
SRM-040-310	310
4.5mm Shanks - D1	
SRM-045-100	100
5mm Shanks - D1	
SRM-050-050	50
SRM-050-100	100
SRM-050-310	310
5.5mm Shanks - D1	
SRM-055-100	100
6mm Shanks - D1	
SRM-060-057	57
SRM-060-100	100
SRM-060-310	310
6.5mm Shanks - D1	
SRM-065-100	100

SRM Catalog No.	Overall Length (L1) mm
7mm Shanks - D1	
SRM-070-100	100
SRM-070-310	310
8mm Shanks - D1	
SRM-080-063	63
SRM-080-100	100
SRM-080-310	310
9mm Shanks - D1	
SRM-090-100	100
SRM-090-310	310
10mm Shanks - D1	
SRM-100-072	72
SRM-100-100	100
SRM-100-310	310
11mm Shanks - D1	
SRM-110-310	310
12mm Shanks - D1	
SRM-120-083	83
SRM-120-100	100
SRM-120-310	310
13mm Shanks - D1	
SRM-130-310	310
14mm Shanks - D1	
SRM-140-100	100
16mm Shanks - D1	
SRM-160-100	100
SRM-160-310	310
18mm Shanks - D1	
SRM-180-100 ♦	100
19mm Shanks - D1	
SRM-190-310 ♦	310
20mm Shanks - D1	
SRM-200-100 ♦	100
25mm Shanks - D1	
SRM-250-310 ♦	310

♦ WHILE SUPPLIES LAST - Discontinued

K

MICRO 100®
super carbide tools

*World Class Quality
Through Manufacturing Excellence*

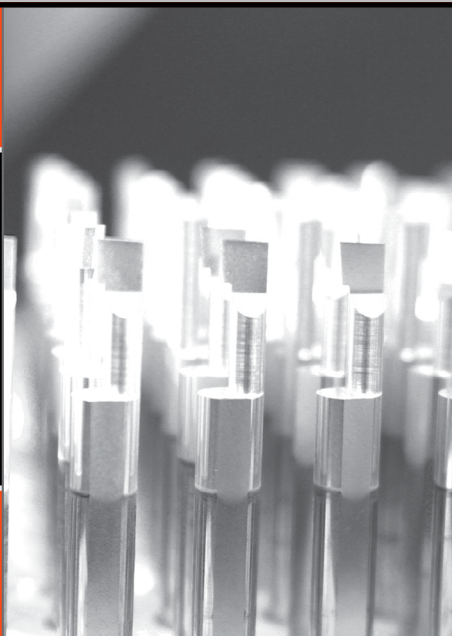

- Technical Data
- Coatings Chart
- Coating Services
- Machining Formulas
- Boring Tools
- Grooving Tools
- Internal Threading Tools
- End Mills
- End Mills - Ball Nose
- End Mills Trouble Shooting
- Thread Mill Assist
- Engraving Tools



**WILL NOT CHIP OR BREAK
UNDER NORMAL MACHINING CONDITIONS**



Technical Data
page 275



Internal Threading Tools
page 282, 283

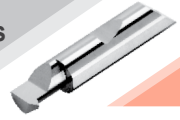

Coatings Chart
page 276



End Mills
page 284-299



Coating Services
page 277



End Mills - Ball Nose
page 300, 301

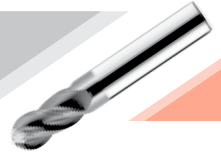

Machining Formulas
page 278

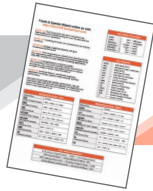

End Mills
Trouble Shooting
page 302



Boring Tools
page 279

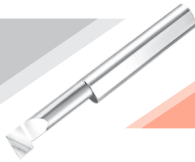

Thread Mill Assist
page 303

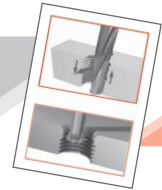

Grooving Tools
page 280, 281



Engraving Tools
page 304, 305



For current pricing and availability please visit our website at www.micro100.com

The recommendations listed in this "Technical Data Section", should only be considered "Safe Starting Points".

Selection of proper tools for the required machining applications and/or conditions include, but, not limited to, rigidity of setups, tool overhang, tool clearances, and finished surface requirements in order to achieve successful machining outcomes.

Surface speeds, feed rates, machine RPM and depth of cut will vary depending on materials being machined. Adjustments and variations may be necessary to achieve the optimum machining performances and superior tool life.

Coated versions of selected tools may allow you to increase Speed/Feed rates by 25% or more. Coating on a tool will not compensate for poor initial tool selection.

MICRO 100 Tool Corporation has no control over the conditions for which the products we manufacture may be subjected to. It is highly recommended that the user(s) of products manufactured by MICRO 100 Tool Corporation abide by the guidelines and/or standards in regard to the type of machinery our products will be used on. Common safety practices and precautions should always be enforced.

During machining applications, "hot flying" chips may be projected from the workpiece or a rotating part of the machine tool. If carbide tool material is subjected to over-stress and/or severe impact, it may fracture causing small fragments to be dispelled. For such instances, precautionary safety methods must be implemented to protect the operator(s) and/or observer(s). These safety measures may include, but not be limited to, appropriate safety glasses with wrap around eye protection and/or safety shields to protect everyone in the immediate area of where machining operations are being performed.

Grinding products manufactured by MICRO 100 Tool Corporation will produce a dust and/or mist that may be hazardous. Using commonly accepted safety practices is recommended.

Any modification(s) of the products manufactured by MICRO 100 Tool Corporation by the customer and/or any end user will void any and all specifications and/or guarantees listed.

Designs, specifications, product improvements and/or pricing of any products manufactured by MICRO 100 Tool Corporation are subject to change without notice.



**THERE ARE MANY BRANDS OF MICRO-GRAIN CARBIDE TOOLS
BUT, THERE IS ONLY ONE**



**MICRO GRAIN CARBIDE +PLUS, YOUR SUPER CARBIDE TOOLS
IN A CLASS OF THEIR OWN!**

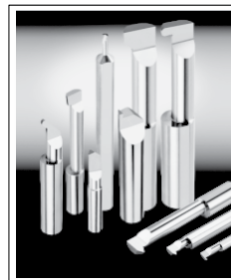

For current pricing and availability please visit our website at www.micro100.com

The information/data provided below, is intended as guidelines for comparing coatings and general application recommendations as to types of materials where performance and optimal tool life may be recognized.

Choose the coating for your machining application and simply add the "Catalog Tool Designation Letter" to the end of the Catalog Tool Number...please see example:
BB-180350X by placing an **"X"** at the end of the Catalog Tool Number, designates the tool will be supplied with an **AITiN** coating.

Coating Name	Recommended Materials	Catalog Tool Designation Letter	Characteristics and Benefits	Coating Color and Structure
AITiN Aluminum Titanium Nitride	Alloy Steels, Stainless Steels, Tool Steels, Nickel Alloys and Titaniums	X	High performance and versatile coating. Higher breakdown temperature. Maintains high surface hardness at elevated temperatures, promotes tool life and allows for faster feeds and speeds. Excellent for dry-machining.	Color: Gray / Black Structure: Multi-Layer Hardness (Vickers): 4500 (90Rc) Oxidation Temperature: 800 °C (1450 °F) Friction Coefficient: 0.45 Thickness: 2-5 microns
nACRo® Aluminum Chromium Nitride Silicone	Aluminum Alloys Steels, Carbon Steels, Stainless Steels, Hardened Steels, Nickel Alloys, Cast Irons Titanium, and most High Temperature Alloys	K	EXTREMELY heat and scratch resistant coating that provides exceptional performance for those "tough and difficult" materials where temperatures increase dramatically during the machining application.	Color: Blue / Gray Structure: Nano Composite Multi-Layer Hardness (Vickers): 4000 (HV 0.05) Oxidation Temperature: 1100 °C (2102 °F) Friction Coefficient: 0.35 Thickness: 1-7 microns
TiN Titanium Nitride	General Purpose and Non-Ferrous Materials	G	General purpose coating with proven performance and increasing tool productivity with higher feeds and speeds in the machining of ferrous materials and in applications that are not generating excessive/extreme heat.	Color: Gold Structure: Mono-Layer Hardness (Vickers): 2300 (81 Rc) Oxidation Temperature: 550 °C (1050 °F) Friction Coefficient: 0.5 Thickness: 2-5 microns
SPECIALTY COATINGS				
ZrN Zirconium Nitride	Abrasive Non-Ferrous Alloys, Brass, Bronze, Copper and most types of Aluminums	S	Better tool performance over uncoated carbide in numerous non-ferrous materials. Characteristics include a high hardness with lubricity and abrasion resistance. Generally, a less expensive alternative to diamond coatings.	Color: Light Silver Structure: Mono-Layer Hardness (Vickers): 2800 (88Rc) Oxidation Temperature: 593 °C (1100 °F) Friction Coefficient: 0.50 Thickness: 2-5 microns
MoS2 Molybdenum Disulfide	6061, 7075 Aluminums or Non-Ferrous Alloys, Low-Silicon Content Applications	M	This coating is best used in dry machining of 6061 and 7075 aluminums. It is initially black in color and turns to clear through chemical changes when used.	Color: Black (Clear when used) Structure: Mono-Layer Hardness (Vickers): N/A (Dry-Film Lubricant) Oxidation Temperature: 316 °C (600 °F) Friction Coefficient: 0.05 Thickness: 0.05 microns
TiCN Titanium Carbonitride	Cast Irons, High Silicon Aluminum Alloys, Copper and most abrasive materials	T	This coating features a hard, smooth finish that offers improved wear and resistance to edge build up. Provides good adhesion, toughness, and resistance to chipping. Performs well where moderate temperatures are generated at the tool's cutting edge. Coolant must be applied on the tool's cutting edge to control the temperature.	Color: Blue/Grey Structure: Mono-Layer Hardness (Vickers): 3000 (87Rc) Oxidation Temperature: 400 °C (752 °F) Friction Coefficient: 0.45 Thickness: 1-4 microns
TiAlN Titanium Aluminum Nitride	High Strength Steels High Temperature Alloys including Nickel Base and Titaniums	N	Features a hard aluminum oxide layer for hot, dry machining applications of which reflects the heat back into the chip and away from the tool and the workpiece. Due to greater ductility, this coating performs well for interrupted cuts and longer tool life in high heat applications.	Color: Violet Bronze Structure: Mono-Layer Hardness (Vickers): 2800 (85Rc) Oxidation Temperature: 800 °C (1450 °F) Friction Coefficient: 0.70 Thickness: 2-5 microns

Contact our Customer Service Department for the Weekly Coating Schedule, Pricing, and more Details.

CONTACT US TODAY FOR MORE DETAILS.

MICRO 100 Tool Corporation is pleased to offer our Coating Services to you.

Cutting Tools with coatings, when properly applied, can improve tool life and performance. Coatings lower the friction coefficient, thermal conductivity, and chemically inert surface by increasing the surface hardness.

Our experienced tool coating specialists are well trained and are ready to discuss your specific machining. application needs to better determine the type of coating(s) that will provide you with the best results.



MICRO 100 Coating Services and Capabilities:

- TIN (titanium nitride)
- AlTiN (aluminum titanium nitride)
- ZrN (zirconium nitride)
- Nano-Tek / CR w/Polish (aluminum titanium nitride nano)
- Coat both Single and Double End Tools
- 1/8" up to 1" Shanks
- 3mm up to 25mm Shanks
- Overall tool lengths up to 6"
- Overall tool lengths up to 153 mm

Advantages of the MICRO 100 Coating Services:

- Guaranteed Efficient Coating Procedures
- Guaranteed Quality
- Timely Turn-a-Rounds
- State of the Art Coating Technologies
- Added Performance and Value to Cutting Tools
- Call Customer Service for Advice and Recommendations



For more details on this service and any other questions you may have concerning the High Quality, Super Carbide Products manufactured by **MICRO 100** Tool Corporation... contact us today at 1-800-421-8065!

Feeds & Speeds Wizard online as well:

<http://micro100.hsmadvisor.com>

MICRO 100 Tool Corporation has been manufacturing high-quality solid carbide tooling for over 50 years and we are proud of our reputation.

MICRO 100 machining formulas are considered to be industry standards.

MICRO 100 tooling, if applied properly, will give exceptional performance.

MICRO 100 Tool Corporation is a World Class Grinding facility. Our engineering staff is outstanding and would be pleased to help offer solutions for your difficult machining applications.

MICRO 100 is recognized as an Industry Leader. Our proprietary micro grain carbide cutting tool products provide you, the customer, the highest transverse rupture strength in today's market. Other benefits of

MICRO 100 products feature, unmatched toughness, application versatility, superior metal removal, and tool performance.

Our goal is to provide high-quality, performance. We will treat each order with the care and attention to detail that you expect and deserve. Earning your business on a consistent basis is very important to us.

Inch / Metric Conversions

Inches	x	25.4 =	Millimeters
Inches	x	2.54 =	Centimeters
Millimeters	x	0.03937 =	Inches
Centimeters	x	0.3937 =	Inches
Millimeters	÷	25.4 =	Inches
Centimeters	÷	2.54 =	Inches

List of Symbols

ADOC	=	Axial Depth Of Cut
D(d)	=	Diameter of Cutter or Bore Size
DOC	=	Depth Of Cut
FPT	=	Feed Rate Per Tooth
FPR	=	Feed Rate Per Revolution
IPM	=	Inches Per Minute
IPT	=	Inch Per Tooth/Flute Chipload
MRR	=	Metal Removal
NOT	=	Number of Teeth/Flutes
PC	=	Power Constants
RDOC	=	Radial Depth Of Cut
RPM	=	Revolutions Per Minute
SFM	=	Surface Footage Per Minute
Z	=	Number of Flutes

Machining Formulas - Inch

Need to Know	Formula
SFM Surface Footage Per Minute	$SFM = 0.262 \times D \times RPM$
RPM Revolutions Per Minute	$RPM = 3.82 \times SFM \div D$
IPM Inches Per Minute	$IPM = FPT \times NOT \times RPM$
IPT (FPT) Inches Per Tooth / Chipload	$IPT = IPM \div RPM \div NOT \text{ or } Z$
IPR (FPR) Inch Feed Per Revolution	$IPR (FRR) = IPM \div RPM$
CLPT Chipload per Tooth	$CLPT = CLPT \times D$
MRR Metal Removal Rate	$MRR = ADOC \times RDOC \times IPM$
HP Horsepower Requires	$HP = IPM \times RDOC \times ADOC \times PC$

Machining Formulas - Metric

Need to Know:	Formula:
m/min Meters Per Minute	$m/min = 0.00314 \times d \times rpm$
rpm Revolutions Per Minute	$rpm = 318.057 \times m/min \div d$
mm/min Millimeters Per Minute	$mm/min = rpm \times mmpt \times not \text{ or } z$
mmpt Millimeters Per Tooth / Chipload	$mmpt = mm/min \div rpm \times not \text{ or } z$
mmpr(fr) Millimeters (Feed) Per Revolution	$mmpr(fr) = mm/min \div rpm$
mrr Metal Removal Rate	$mrr = adoc \times rdoc \times mm/min \times 1000$
hp Horsepower Requires	$hp = mm/min \times rdoc \times adoc \times .001 \times pc$
kW	$kW = .7457 \times hp$

Inch / Metric Conversions

$S.F.M. (Surface Footage Per Minute) \div 0.3048 = m/min (Meters per Minute)$
$I.P.M. (Inches Per Minute) = mm/min (Millimeters Per Minute) \div 25.4$
$m/min (Meters per Minute (m/min)) = sfm (Surface Footage Per Minute) \times 0.304$
$mm/min (Millimeters per Minute (m/min)) = ipm (Inches Per Minute) \times 25.4$

Safe Starting Conditions for Boring Applications

MATERIALS	BHN	SURFACE SPEED (SFM)	FEED RATE (I.P.R.)	DEPTH OF CUT* (per side/inch)	SURFACE SPEED (m/min)	FEED RATE (mm/r)	DEPTH OF CUT* (per side/mm)
NON-FERROUS MATERIALS							
Aluminum - Aluminum Alloys	140-425	175-2000	.0005-.030	.0002-.090	53-610	.013-.076	.005-2.3
Brass - Bronze	80-120	175-2000	.0005-.030	.0002-.090	53-457	.013-.076	.005-2.3
Copper	80-120	150-400	.0005-.030	.0002-.090	61-457	.013-.076	.005-2.3
Zinc Alloys	80-120	150-350	.0005-.030	.0002-.090	46-107	.013-.076	.005-2.3
Non-Metallics	-	200-1000	.0005-.030	.0002-.090	61-305	.013-.076	.005-2.3
Acrylics	-	200-1000	.0005-.030	.0002-.090	61-305	.013-.076	.005-2.3
Fiberglass	-	200-1000	.0005-.030	.0002-.090	61-305	.013-.076	.005-2.3
Graphites	-	200-1000	.0005-.030	.0002-.090	61-305	.013-.076	.005-2.3
Nylons	-	200-1000	.0005-.030	.0002-.090	61-305	.013-.076	.005-2.3
Phenolics	-	200-1000	.0005-.030	.0002-.090	61-305	.013-.076	.005-2.3
Plastics	-	200-1000	.0005-.030	.0002-.090	61-305	.013-.076	.005-2.3
CAST IRONS							
Cast Iron - Gray	160-260	100-900	.0005-.025	.0002-.030	30-84	.013-.064	.005-.076
Cast Iron - Ferritic	140-200	75-750	.0005-.025	.0002-.030	23-229	.013-.064	.005-.076
Cast Iron - Pearlitic	220-260	75-650	.0005-.025	.0002-.030	23-198	.013-.064	.005-.076
Iron - SG Nodular	160-260	164-262	.0005-.025	.0002-.030	50-80	.013-.064	.005-.076
STEELS							
Low Carbon - Unalloyed	160-260	75-800	.0005-.015	.0002-.025	23-244	.013-.038	.005-.064
Medium Carbon - Unalloyed	140-200	75-800	.0005-.015	.0002-.025	23-244	.013-.038	.005-.064
High Carbon - Unalloyed	220-260	75-800	.0005-.015	.0002-.025	23-244	.013-.038	.005-.064
Low Carbon Alloys	220-260	75-800	.0005-.015	.0002-.025	23-244	.013-.038	.005-.064
Medium Carbon Alloys	220-260	75-800	.0005-.015	.0002-.025	23-244	.013-.038	.005-.064
High Strength Alloys	220-260	75-600	.0005-.015	.0002-.025	23-183	.013-.038	.005-.064
Tool Steels	220-250	75-500	.0005-.015	.0002-.025	23-152	.013-.038	.005-.064
Heat Treated Alloys	32-40RC	75-250	.0005-.015	.0002-.025	23-76	.013-.038	.005-.064
Powder Metal Alloys	230-260	75-250	.0005-.015	.0002-.025	23-76	.013-.038	.005-.064
STAINLESS STEELS							
300 Series	135-185	75-500	.0005-.015	.0002-.025	23-152	.013-.038	.005-.064
400 Series	180-220	75-500	.0005-.015	.0002-.025	23-152	.013-.038	.005-.064
13-8 PH	32-35RC	75-500	.0005-.015	.0002-.025	23-152	.013-.038	.005-.064
15-5 PH	32-35RC	75-500	.0005-.015	.0002-.025	23-152	.013-.038	.005-.064
17-4 PH	32-35RC	75-500	.0005-.015	.0002-.025	23-152	.013-.038	.005-.064
HIGH TEMPERATURE ALLOYS							
Monel 400	140-300	70-300	.0003-.010	.0002-.020	21-91	.013-.025	.005-.051
Monel 500	140-300	70-300	.0003-.010	.0002-.020	21-91	.013-.025	.005-.051
K Monel	140-300	70-300	.0003-.010	.0002-.020	21-91	.013-.025	.005-.051
A286	225-363	75-300	.0003-.010	.0002-.020	23-91	.013-.025	.005-.051
Hastelloy	225-363	75-300	.0003-.010	.0002-.020	23-91	.013-.025	.005-.051
Inconel	225-363	75-300	.0003-.010	.0002-.020	23-91	.013-.025	.005-.051
Rene	225-363	75-300	.0003-.010	.0002-.020	23-91	.013-.025	.005-.051
Waspalloy	225-363	75-300	.0003-.010	.0002-.020	23-91	.013-.025	.005-.051
HARDENED MATERIALS							
Titanium Alloys	300-500	70-140	.0002-.008	.0001-.005	21-43	.005-.020	.003-.013
Extra Hard Steels	45-50RC	65-147	.0001-.005	.0001-.005	20-45	.003-.013	.003-.013
Hardened and Tempered	51-55RC	65-131	.0001-.005	.0001-.005	20-40	.003-.013	.003-.013

Machining Data for Speeds, Feeds, and Depth of Cuts are considered to be "safe starting conditions" and may need to be adjusted to obtain optimal performance.

For greater Depth of Cuts...reduce the Feed Rates. Depth of Cuts not recommended to exceed 20% of the D1 dimension.
To obtain better surface finish, reduce Feed Rates.

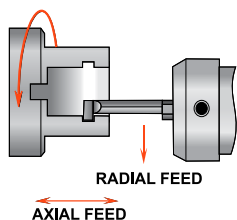

The Recommendations listed below should be considered to be only as starting points.

Selection of proper tools for the required machining applications and/or conditions such as, but not limited to, rigidity of setups, tool overhang, tool clearances, and surface finish requirements.

Surface Speeds, Feed Rates, Machine RPM, and Depth of Cuts will vary depending on materials being machined. Adjustments and variations may be necessary to achieve optimum machining performances and prolonged tool life.

Coated versions of selected tools may allow you to increase Speed/Feed rates by 25% or more.

During Machining applications, it is recommended that the operator(s) and/or observer(s) use precautions such as, but not limited to...safety glasses with wrap around eye protection and/or safety shields on the machine(s). Grinding products manufactured by MICRO 100 Tool Corporation will produce a dust/mist that may be hazardous. Using common safety practices is recommended.

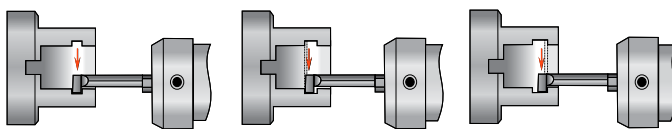

GROOVE WIDTHS "SLIGHTLY" WIDER THAN THE WIDTH OF THE GROOVING TOOL

Plunge the center of the desired groove location.

Plunge each side of the groove to obtain the specified width.

Slower "feed rates" should be used during this operation.

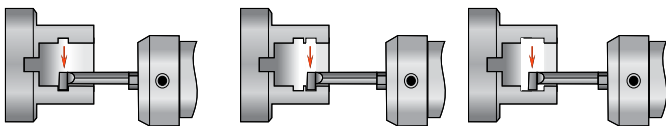

GROOVE WIDTHS WIDER THAN THE WIDTH OF THE GROOVING TOOL

Plunge out both sides of the desired groove width.

Plunge the center area to remove excess material.

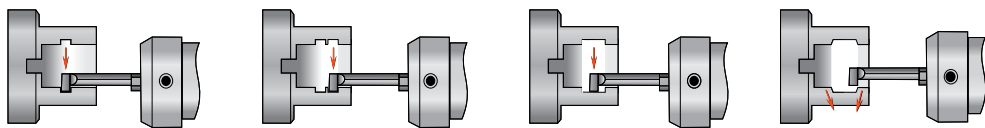

GROOVE WIDTHS WIDER THAN THE WIDTH OF THE GROOVING TOOL WITH A "SPECIFIED" ANGLE

Plunge out both sides of the desired groove width.

Plunge the center area to remove excess material.

Plunge both sides of the groove at the specified angle calculating approximately 1/2 of the "maximum" width of the tool.

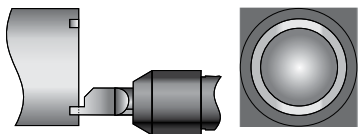

FACE GROOVING

Groove Widths from .020"(.50mm) to .156"(3.96mm)

are typically used in applications to create

Face Grooves with

Major Diameters greater than .250"(6.35mm).

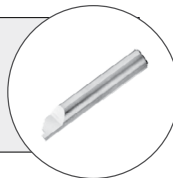

Safe Starting Conditions for Grooving Applications

MATERIALS	BHN	FEED RATE (Radial/Inch)	FEED RATE (Axial/Inch)	FEED RATE (Radial/Metric)	FEED RATE (Axial/Metric)
NON-FERROUS MATERIALS					
Wrought Aluminum Alloys	140-300	.0005-.002	.0003-.005	.013-.051	.008-.127
Cast Aluminum Alloys	225-363	.0005-.002	.0003-.005	.013-.051	.008-.127
High Silicone Aluminum Alloys	270-425	.0005-.002	.0003-.005	.013-.051	.008-.127
Brass	80-120	.0005-.002	.0003-.005	.013-.051	.008-.127
Bronze	80-120	.0005-.002	.0003-.005	.013-.051	.008-.127
Non-Leaded Copper	80-120	.0005-.002	.0003-.005	.013-.051	.008-.127
Zinc Alloys	80-120	.0005-.002	.0003-.005	.013-.051	.008-.127
Non-Metallics	-	.0005-.002	.0003-.005	.013-.051	.008-.127
Acrylics	-	.0005-.002	.0003-.005	.013-.051	.008-.127
Fiberglass	-	.0005-.002	.0003-.005	.013-.051	.008-.127
Graphites	-	.0005-.002	.0003-.005	.013-.051	.008-.127
Nylons	-	.0005-.002	.0003-.005	.013-.051	.008-.127
Phenolics	-	.0005-.002	.0003-.005	.013-.051	.008-.127
Plastics	-	.0005-.002	.0003-.005	.013-.051	.008-.127
CAST IRONS					
Cast Iron - Gray	160-260	.0005-.002	.0003-.005	.013-.051	.008-.127
Cast Iron - Ferritic	140-200	.0005-.002	.0003-.005	.013-.051	.008-.127
Cast Iron - Pearlitic	220-260	.0005-.002	.0003-.005	.013-.051	.008-.127
Iron - SG Nodular	160-260	.0005-.002	.0003-.005	.013-.051	.008-.127
STEELS					
Low Carbon - Unalloyed	160-260	.0005-.002	.0003-.005	.013-.051	.008-.127
Medium Carbon - Unalloyed	140-200	.0005-.002	.0003-.005	.013-.051	.008-.127
High Carbon - Unalloyed	220-260	.0005-.002	.0003-.005	.013-.051	.008-.127
Low Carbon Alloys	220-260	.0005-.002	.0003-.005	.013-.051	.008-.127
Medium Carbon Alloys	220-260	.0005-.002	.0003-.005	.013-.051	.008-.127
High Strength Alloys	220-260	.0005-.002	.0003-.005	.013-.051	.008-.127
Tool Steels	220-250	.0005-.002	.0003-.005	.013-.051	.008-.127
Heat Treated Alloys	32-40RC	.0005-.002	.0003-.005	.013-.051	.008-.127
Powder Metal Alloys	230-260	.0005-.002	.0003-.005	.013-.051	.008-.127
STAINLESS STEELS					
300 Series	135-185	.0005-.002	.0003-.005	.013-.051	.008-.127
400 Series	180-220	.0005-.002	.0003-.005	.013-.051	.008-.127
13-8 PH	32-35RC	.0005-.002	.0003-.005	.013-.051	.008-.127
15-5 PH	32-35RC	.0005-.002	.0003-.005	.013-.051	.008-.127
17-4 PH	32-35RC	.0005-.002	.0003-.005	.013-.051	.008-.127
HIGH TEMPERATURE ALLOYS					
Monel 400	140-300	.0005-.002	.0003-.005	.013-.051	.008-.127
Monel 500	140-300	.0005-.002	.0003-.005	.013-.051	.008-.127
K Monel	140-300	.0005-.002	.0003-.005	.013-.051	.008-.127
A286	225-363	.0005-.002	.0003-.005	.013-.051	.008-.127
Hastelloy	225-363	.0005-.002	.0003-.005	.013-.051	.008-.127
Inconel	225-363	.0005-.002	.0003-.005	.013-.051	.008-.127
Rene	225-363	.0005-.002	.0003-.005	.013-.051	.008-.127
Waspalloy	225-363	.0005-.002	.0003-.005	.013-.051	.008-.127
HARDENED MATERIALS					
Titanium Alloys	300-500	.0005-.002	.0003-.005	.013-.051	.008-.127
Extra Hard Steels	45-50RC	.0005-.002	.0003-.005	.013-.051	.008-.127
Hardened and Tempered	51-55RC	.0005-.002	.0003-.005	.013-.051	.008-.127



Machining Data for Speeds, Feeds, and Depth of Cuts are considered to be "safe starting conditions" and may need to be adjusted to obtain optimal performance. For greater Depth of Cuts...reduce the Feed Rates. To obtain better surface finish, reduce Feed Rates.

For current pricing and availability please visit our website at www.micro100.com

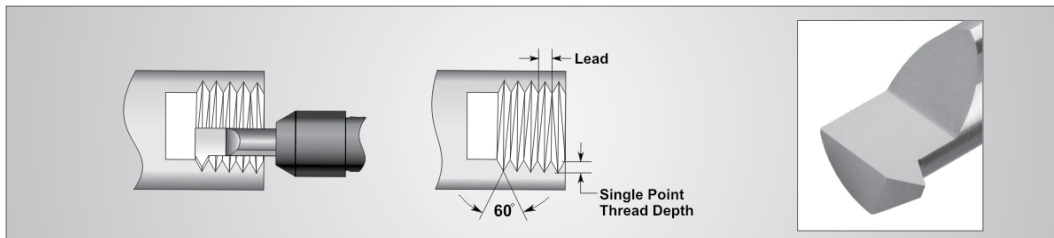
Single Point Threading

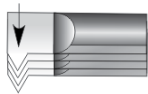
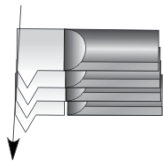
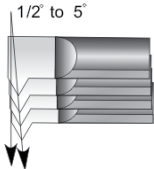

Methods of Infeed

RADIAL		Most widely used infeed method. This method creates the most cutting force on the tool due to the entire tool cutting edge being engaged in the cut.
FLANK		This infeed method allows for a more "evenly" formed chip. Reduction of heat generated by this method promotes longer tool edge life.
MODIFIED FLANK		This infeed method reduces the cutting force and will wear one edge of the insert. Less heat and better chip flow can be expected with this method.
ALTERNATE		This infeed method reduces the cutting force and will wear one edge of the insert. Less heat and better chip flow can be expected with this method.

T.P.I.	8	10	12	14	16	18	20	24	28	32	36	40	44	48	56
	3.18	2.54	2.12	1.81	1.59	1.41	1.27	1.06	0.91	0.80	0.71	0.64	0.58	0.53	0.45
NUMBER OF PASSES	12-14	10-12	8-10	8-10	8-10	6-8	6-8	6-8	6-8	4-6	4-6	4-6	4-6	4-6	4-6

Conditions based on Mild Steel and Non-Ferrous materials. Harder materials and/or High Temperature Alloys may require more passes. The data given in the chart above should always be considered "safe starting conditions" and may need to be adjusted to obtain optimal machining performance.

For current pricing and availability please visit our website at www.micro100.com

Safe Starting Conditions for Grooving Applications

MATERIALS	BHN	FEED RATE (Radial/Inch)	FEED RATE (Axial/Inch)	FEED RATE (Radial/Metric)	FEED RATE (Axial/Metric)
NON-FERROUS MATERIALS					
Wrought Aluminum Alloys	140-300	.0005-.002	.0003-.005	.013-.051	.008-.127
Cast Aluminum Alloys	225-363	.0005-.002	.0003-.005	.013-.051	.008-.127
High Silicone Aluminum Alloys	270-425	.0005-.002	.0003-.005	.013-.051	.008-.127
Brass	80-120	.0005-.002	.0003-.005	.013-.051	.008-.127
Bronze	80-120	.0005-.002	.0003-.005	.013-.051	.008-.127
Non-Leaded Copper	80-120	.0005-.002	.0003-.005	.013-.051	.008-.127
Zinc Alloys	80-120	.0005-.002	.0003-.005	.013-.051	.008-.127
Non-Metallics	-	.0005-.002	.0003-.005	.013-.051	.008-.127
Acrylics	-	.0005-.002	.0003-.005	.013-.051	.008-.127
Fiberglass	-	.0005-.002	.0003-.005	.013-.051	.008-.127
Graphites	-	.0005-.002	.0003-.005	.013-.051	.008-.127
Nylons	-	.0005-.002	.0003-.005	.013-.051	.008-.127
Phenolics	-	.0005-.002	.0003-.005	.013-.051	.008-.127
Plastics	-	.0005-.002	.0003-.005	.013-.051	.008-.127
CAST IRONS					
Cast Iron - Gray	160-260	.0005-.002	.0003-.005	.013-.051	.008-.127
Cast Iron - Ferritic	140-200	.0005-.002	.0003-.005	.013-.051	.008-.127
Cast Iron - Pearlitic	220-260	.0005-.002	.0003-.005	.013-.051	.008-.127
Iron - SG Nodular	160-260	.0005-.002	.0003-.005	.013-.051	.008-.127
STEELS					
Low Carbon - Unalloyed	160-260	.0005-.002	.0003-.005	.013-.051	.008-.127
Medium Carbon - Unalloyed	140-200	.0005-.002	.0003-.005	.013-.051	.008-.127
High Carbon - Unalloyed	220-260	.0005-.002	.0003-.005	.013-.051	.008-.127
Low Carbon Alloys	220-260	.0005-.002	.0003-.005	.013-.051	.008-.127
Medium Carbon Alloys	220-260	.0005-.002	.0003-.005	.013-.051	.008-.127
High Strength Alloys	220-260	.0005-.002	.0003-.005	.013-.051	.008-.127
Tool Steels	220-250	.0005-.002	.0003-.005	.013-.051	.008-.127
Heat Treated Alloys	32-40RC	.0005-.002	.0003-.005	.013-.051	.008-.127
Powder Metal Alloys	230-260	.0005-.002	.0003-.005	.013-.051	.008-.127
STAINLESS STEELS					
300 Series	135-185	.0005-.002	.0003-.005	.013-.051	.008-.127
400 Series	180-220	.0005-.002	.0003-.005	.013-.051	.008-.127
13-8 PH	32-35RC	.0005-.002	.0003-.005	.013-.051	.008-.127
15-5 PH	32-35RC	.0005-.002	.0003-.005	.013-.051	.008-.127
17-4 PH	32-35RC	.0005-.002	.0003-.005	.013-.051	.008-.127
HIGH TEMPERATURE ALLOYS					
Monel 400	140-300	.0005-.002	.0003-.005	.013-.051	.008-.127
Monel 500	140-300	.0005-.002	.0003-.005	.013-.051	.008-.127
K Monel	140-300	.0005-.002	.0003-.005	.013-.051	.008-.127
A286	225-363	.0005-.002	.0003-.005	.013-.051	.008-.127
Hastelloy	225-363	.0005-.002	.0003-.005	.013-.051	.008-.127
Inconel	225-363	.0005-.002	.0003-.005	.013-.051	.008-.127
Rene	225-363	.0005-.002	.0003-.005	.013-.051	.008-.127
Waspalloy	225-363	.0005-.002	.0003-.005	.013-.051	.008-.127
HARDENED MATERIALS					
Titanium Alloys	300-500	.0005-.002	.0003-.005	.013-.051	.008-.127
Extra Hard Steels	45-50RC	.0005-.002	.0003-.005	.013-.051	.008-.127
Hardened and Tempered	51-55RC	.0005-.002	.0003-.005	.013-.051	.008-.127

Machining Data for Speeds, Feeds, and Depth of Cuts are considered to be "safe starting conditions" and may need to be adjusted to obtain optimal performance. For greater Depth of Cuts...reduce the Feed Rates.



Carbide End Mill Trouble Shooting Guide
for Problems, Causes, and Recommended Solutions.

Problems	Causes	Recommended Solutions
Chipping	Feed Rate is too fast on first cut. Feed Rate is too fast. Lack of rigidity (machine & toolholder). Lack of rigidity (tool). Tool corner is too sharp. Tool edges chipping.	Reduce Feed Rate on first pass. Reduce Feed Rate. Utilize machine and toolholder that has better rigidity. Use a shorter end mill, try climb milling. Change to lower cutting angle, decrease primary angle. Hone cutting edge(s).
Chattering	Feed and Speed is too fast. Lack of rigidity (machine & toolholder). Too much relief angle. Cut is too deep. Flute length tool long. Too much overhang.	Correct Feeds and Speeds. Utilize machine and toolholder that has better rigidity. Change to a smaller relief, add margin (touch primary with oilstone). Decrease width and depth of cut. Use a shorter end mill. Hold end mill shank deeper in toolholder.
Excessive Wear	Speed is too fast. Hard work material. Improper speed and feed (too slow). Wrong helix angle. Primary relief angle (too large). Recutting chips.	Decrease spindle speed and use more coolant. Utilize coated end mills. Increase feeds and speeds (try down cut). Select end mill with smaller relief angle. Change feed and speed to change chip size (use more coolant/air to clear chips).
Leaving Burrs	Too much wear on primary angle. Incorrect feeds and speeds. Wrong helix angle.	Regrind end mill sooner Correct cutting parameters. Change to end mill with appropriate helix angle.
Poor Finish	Feed rate is too fast. Milling speed is too slow. Too much tool wear. No end tooth concavity. Recutting chips.	Reduce feed rate. Increase RPM. Regrind end mill at an earlier stage. Grind concave angle on bottom teeth. Change feed and speed to change chip size (use more coolant/air to clear chips).
Chip Packing	Cut is too heavy. Not enough chip clearance. Not enough coolant/air.	Decrease width and depth of cut. Use end mill with less flutes. Higher coolant pressure and direct nozzle to point if cut or use air.
Short Tool Life	Cutting friction is too great. Hard work material. Improper helix and relief angle.	Regrind end mill at an earlier stage. Use coated end mills. Change to end mill with appropriate helix and relief angles.
No Dimensional Accuracy	Cut is too heavy. Lack of accuracy (machine/toolholder). Not enough rigidity (machine/toolholder). Not sufficient number of flutes.	Decrease width and depth of cut. Repair machines/toolholder. Change machine/toolholder or milling parameters. Use multi-flute end mills
No Perpendicular Side	Feed is too fast. Cutting amount is too great. Flute length too long. Not sufficient number of flutes.	Decrease feed rate. Reduce depth of cuts. Change to shorter end mill. Use multi-flute end mills.
Breakage	Feed is too fast. Cutting amount is too great. Overhang of end mill is too much. Wear is too much.	Reduce feed rate. Reduce width and depth of cuts. Hold end mill shank deeper in toolholder or use shorter end mill. Regrind end mill sooner.
Welding or Galling	Cutting speed is too low. End Mill not sharp enough.	Increase surface feet per minute. Increase rake angle.











Please contact our Technical Department for more information.

For current pricing and availability please visit our website at www.micro100.com

MICRO 100 “Super Carbide End Mills”

are designed and engineered for optimum cutting speeds, feeds, and maximum rigidity with virtually no tool deflection. These features allow for higher metal removal rates with fewer re-grinds.

It is important to select the appropriate End Mill diameter for the application along with the number of flutes that will provide the most efficiency.

Number of Flutes	Helix Angle	Recommended Materials
2	30°	 Soft materials requiring increased chip evacuation.
3	30°	 Slotting applications in soft materials and steels.
4	30°	 Steels, Stainless Steels, and Alloys.
6	38°	 Finish cuts with extremely good surface finish. Excellent for very hard materials and thin walled parts
2	45°	 High Speed machining of aluminum, non-ferrous, and other soft materials. Diminishes chatter when machining corners of parts.
3	45°	 High Speed machining of aluminum, non-ferrous, and other soft materials. Also applicable in some stainless steels and high-temperature alloys.
5	45°	 High metal removal rates in medium to hard steels, stainless steels, high-temperature alloys, and provides excellent surface finish.
3	60°	 High spiral design for high metal removal rates in most steels and stainless steels.
4	60°	 High spiral design for high metal removal rates in most inconels and titaniums.
4	Variable	 High metal removal rates in most hard to machine and heat-treated materials.
5	Variable	 High metal removal rates in most hard to machine and heat-treated materials.

For current pricing and availability please visit our website at www.micro100.com



Choosing the correct end mill and method of application for your specific needs are key factors and essential to performance and tool life expectancy. The characteristics of Conventional and Climb Milling methods are listed below. Please contact our technical department for any questions you may have concerning your application needs.

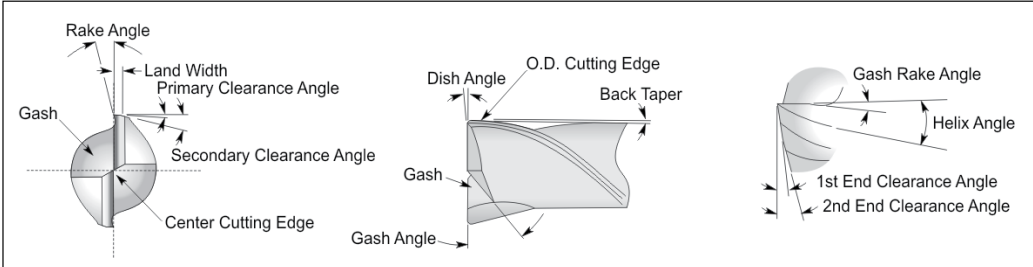

Conventional - "Up" Milling

When utilizing this method of milling, the end mill is revolving in the opposite direction as the table feed. This method of application tends to "accelerate" tool wear and the following characteristics:

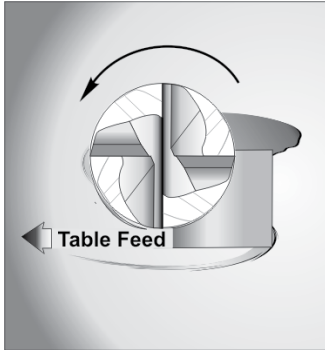

- Width of chip(s) start from zero and increases to a maximum width at the end of the cut increasing tool wear.
- End Mill's teeth meet the workpiece at the bottom of the cut, sometimes causing the end mill to rub causing work hardening.
- More power required (end mill rubbing provoked by chip beginning at maximum width).
- Upward force tends to generally "lift up" the workpiece.
- Surface finish may be "marred or spoiled" due to chips being carried upward by the teeth.
- Chips fall in front of end mill making chip evacuation difficult.
- Preferred method (over climb milling) when milling castings/forgings with very rough surfaces and when removing/breaking through abrasive material scale or flame cut areas.

Climb - "Down" Milling

This method of milling has the end mill revolving in the same direction as the table feed. The end mill's teeth meet the workpiece at the maximum chip thickness. This method of application is proven (in most applications) to be the best with the following characteristics:

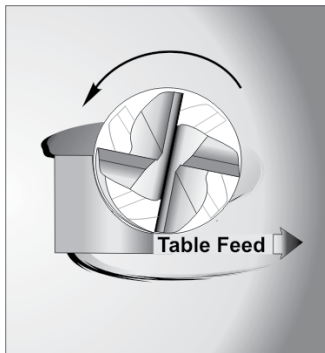

- Width of chip(s) start at the maximum width and decreases, promoting tool performance and tool life.
- Downward force on workpiece minimizes part movement (chatter).
- Less power required (end mills with higher rake angles can be used).
- End Mill's teeth meet the workpiece at the top of the cut, allows for less rubbing and material work hardening.
- Higher initial load and heightened if tools are getting dull. Keeps tools sharp and may increase tool life by as much as 50%
- Chips are removed "behind" end mill for better chip evacuation and surface finishes.
- Proven method over conventional milling. Reduces work hardening when milling heat-treated alloys and stainless steels. Climb milling may cause "chipping" when milling hot rolled steel due to a hardened layer on the surface.

End Mills are designed, engineered, and manufactured for high levels of material removal.

Selecting the "shortest" flute length as possible for your specific application need(s) will offer better rigidity and the ability to increase feed rates.

Next, choose the "largest" cutter diameter possible for your application. Increasing the cutter diameter size by 10% provides 25% more strength and rigidity.

MICRO 100 end mill shank diameter tolerances are tightly held to accommodate shrink fit type tooling

Roughing, Slotting, Pocketing, Peripheral, and Finishing

2 & 3 Fluted End Mills are recommend for milling applications in non-ferrous and most ferrous materials with DOC (depths of cut) not exceeding 1x the cutter diameter per pass.

3, 4, & 5 Fluted End Mills are suitable and recommended for rough pocketing and profiling applications in most ferrous materials.

3, 4, 5, & 6 Fluted End Mills feature greater strength and rigidity with the abilities to increase feed rates boosting productivity in many applications.

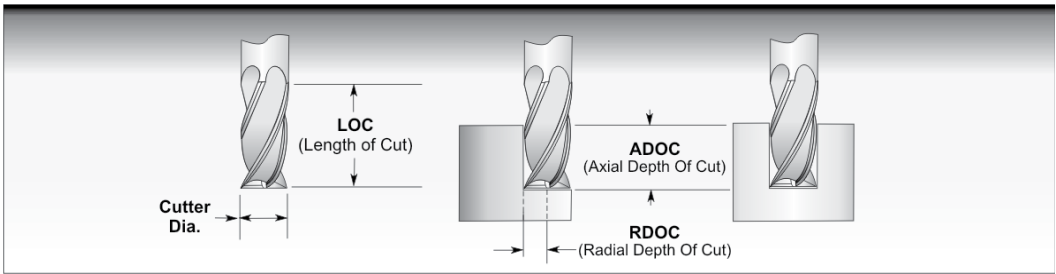

Applications	2 / 3 Flutes	4 Flutes	5 Flutes	6 Flutes
Slotting	ADOC: (up to) 1 x Cutter Dia.	ADOC: (up to) 50% x Cutter Dia.	ADOC: (up to) 50% x Cutter Dia.	.
Light Roughing	ADOC: FL (entire Flute Length) RDOC: 15% - 25% of Cutter Dia.	ADOC: FL (entire Flute Length) RDOC: 15% - 25% of Cutter Dia.	ADOC: FL (entire Flute Length) RDOC: 15% - 25% of Cutter Dia.	ADOC: FL (entire Flute Length) RDOC: 15% - 20% of Cutter Dia.
Heavy Roughing	ADOC: (up to) 1.5 x Cutter Dia. RDOC: 30% - 50% of Cutter Dia.	ADOC: (up to) 1.5 x Cutter Dia. RDOC: 30% - 50% of Cutter Dia.	ADOC: (up to) 1.5 x Cutter Dia. RDOC: 30% - 50% of Cutter Dia.	
Finishing	ADOC: FL (entire Flute Length) RDOC: 3% - 5% of Cutter Dia.	ADOC: FL (entire Flute Length) RDOC: 3% - 5% of Cutter Dia.	ADOC: FL (entire Flute Length) RDOC: 3% - 5% of Cutter Dia.	ADOC: FL (entire Flute Length) RDOC: 3% - 5% of Cutter Dia.

The above data are recommendations and when applied may have to be adjusted to obtain maximum tool performance. When the Depth of Cut required exceeds the maximum FL (Flute Length), we recommend that longer length end mills with a reduced neck be used.

Quick Reference Formulas	
$SFM = \frac{.262 \times D \times RPM}{12}$	$RPM = \frac{SFM \times 3.82}{D}$
$IPM = \frac{RPM \times NOT \times CPT}{D}$	$CPT = \frac{IPM}{RPM} \div NOT$



For current pricing and availability please visit our website at www.micro100.com

MICRO 100 features...Weldon Flats on selected "standard" end mills that have been cylindrically ground to meet and/or exceed shrink fit specifications (H6).



Weldon Flats with factory ground flats:

- No excess run out due to inaccurate hand ground flats.
- Flatness throughout the entire length of the flat(s).
- Parallel with centerline of end mill.

Weldon Flat(s) are typically manufactured from specifications based on NAS 986 (high speed steel standard) and are measured from the shank end. As of to date, there are no standardized specifications for high performance solid carbide end mills. All flats will be ground per the dimensions as shown in the chart below.

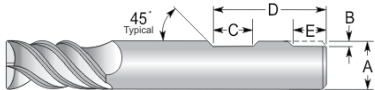
Standard Weldon Shank Dimensions						
	A	B	C	D	E*	
	3/8	.050 - .065	.280 - .282	.921		
	7/16	.050 - .065	.312 - .314	.991		
	1/2	.060 - .075	.330 - .332	1.055		
	9/16	.065 - .080	.400 - .402	1.154		
	5/8	.065 - .080	.400 - .402	1.154		
	3/4	.075 - .090	.455 - .457	1.242		
	7/8	.075 - .090	.455 - .457	1.242		
1	.075 - .090	.515 - .717	1.398			

*Contact our Technical Team for information.

Tolerances for Shrink Fit Toolholders (H6)		
Shank Diameter		Tolerances
Inch	Metric	
≤ .1181	≤ 3mm	- .00000 / - .00024
> .1181 - .2362	> 3mm - 6mm	- .00000 / - .00032
> .2362 - .3937	> 6mm - 10mm	- .00000 / - .00035
> .3937 - .7087	> 10mm - 18mm	- .00000 / - .00043
> .7087 - 1.1811	> 18mm - 30mm	- .00000 / - .00050

Data given was taken from the Machinery's Handbook.



For current pricing and availability please visit our website at www.micro100.com



The Machining Data shown below, is considered to be “safe starting conditions” and may need to be adjusted to obtain optimal tool performance.

SFM (Surface Feed per Minute) can be adjusted between 30%-50% on coated tools (depending on materials and workholding).

For plunging applications in solid materials, reduce feed rates by approximately 50%. Slotting applications, reduce feed by 20%

Safety precautions must be implemented including safety glasses and machine shields to protect the operator and/or observers from hot flying chips.

Our Technical Team is ready to offer solutions for that difficult machining application. Whether you need tool specific speeds, feeds, depth of cuts, grade selection(s) or any questions and/or concerns regarding the application of MICRO 100 Solid Carbide Cutting Tools, they are there to help!

MATERIAL TYPES	SFM (Vc)				Cutter Diameter Chip Load per Tooth (Fz)			
	2 Flute (Stub / Std.)	2 Flute (Extra Lgth.)	3 / 4 Flute (Stub / Std.)	3 / 4 Flute (Extra Lgth.)	1/32 - 1/8	1/8 - 1/4	1/4 - 1/2	1/2 - 1
Non-Ferrous Materials								
Aluminum / Aluminum Alloys								
2014, 2024, 2024, Aircraft Grade(s), 6061, 7075	300 - 500	300 - 500	300 - 500	300 - 500	.0010 - .0020	.0015 - .0040	.0020 - .0060	.0030 - .0116
Brass / Bronze								
High Lead Brass, Red Brass, Yellow Brass, Naval Brass, Low Silicon Brass	300 - 400	200 - 300	275 - 375	200 - 300	.0007 - .0015	.0010 - .0025	.0015 - .0035	.0020 - .0100
Copper / Copper Alloys								
Aluminum Bronze, Low Silicon Bronze Beryllium Copper, Nickel Silver, Oxygen Free Copper	300 - 400	250 - 350	300 - 450	250 - 350	.0007 - .0015	.0010 - .0025	.0015 - .0035	.0020 - .0100
Composites								
Acrylics, Fiberglass, Glass Epoxy, Phenolics, Plastics	200 - 400	200 - 400	200 - 400	200 - 400	.0010 - .0020	.0015 - .0040	.0020 - .0060	.0030 - .0100
Graphites								
	122 - 1015	122 - 1015	122 - 1015	122 - 1015	.0005 - .0015	.0010 - .0020	.0020 - .0050	.0050 - .0080
Magnesium								
	300 - 500	300 - 500	300 - 500	300 - 500	.0010 - .0020	.0015 - .0040	.0020 - .0060	.0030 - .0100
Cast Materials / Irons								
Aluminum								
	250 - 350	250 - 350	250 - 350	250 - 350	.0010 - .0020	.0015 - .0040	.0020 - .0060	.0030 - .0100
Ductile Iron								
	200 - 300	125 - 200	200 - 300	125 - 200	.0005 - .0015	.0010 - .0030	.0015 - .0040	.0020 - .0080
Gray Iron								
	225 - 325	175 - 250	250 - 350	175 - 250	.0010 - .0020	.0015 - .0040	.0020 - .0060	.0030 - .0100
Steels								
	225 - 325	175 - 250	250 - 350	175 - 250	.0010 - .0020	.0015 - .0040	.0020 - .0060	.0030 - .0100



The Machining Data shown below, is considered to be "safe starting conditions" and may need to be adjusted to obtain optimal tool performance.

For plunging applications in solid materials, reduce feed rates by approximately 50%.

MATERIAL TYPES	Hardness (Rc)	SFM (Vc)		Cutter Diameter Feed (Inch/Tooth)			
		3 / 4 Flute (Stub / Std.)	3 / 4 Flute (Extra Lgh.)	1/32 - 1/8	1/8 - 1/4	1/4 - 1/2	1/2 - 1
		Steels					
A36, 12L14	< 35	175 - 250	150 - 200	.0007 - .0015	.0010 - .0025	.0015 - .0040	.0030 - .0060
1100(s), 1200(s), 1300(s)	> 35	100 - 175	100 - 150	.0005 - .0010	.0008 - .0020	.0010 - .0030	.0020 - .0050
Medium Alloy Steels							
200, 250, 300, 86210	< 35	175 - 250	150 - 200	.0007 - .0015	.0010 - .0025	.0015 - .0040	.0030 - .0060
	> 35	100 - 175	100 - 150	.0005 - .0010	.0008 - .0020	.0010 - .0030	.0020 - .0050
High Strength Tool Steels							
A2, D2, H11, H13, 01, S2, 4130, 4340, 5210, 6150	< 30	150 - 225	125 - 175	.0005 - .0010	.0008 - .0020	.0010 - .0030	.0020 - .0050
	30-35	90 - 125	80 - 120	.0003 - .0005	.0005 - .0015	.0010 - .0020	.0010 - .0040
	> 35	60 - 90	50 - 80	.0002 - .0004	.0003 - .0007	.0008 - .0015	.0010 - .0035
Stainless Steels							
Precipitation							
AF-71, AM-350, AM-355, pH Types, 13/8, 15/5, 17-4, 15-7 Mo,	< 35	150 - 250	100 - 150	.0005 - .0010	.0008 - .0020	.0010 - .0030	.0020 - .0050
	> 35	125 - 175	80 - 150	.0003 - .0005	.0005 - .0015	.0010 - .0020	.0010 - .0040
Austenitic							
200 Series, 302, 302, 303	< 35	200 - 250	125 - 175	.0005 - .0010	.0008 - .0020	.0010 - .0030	.0020 - .0050
	> 35	150 - 200	100 - 150	.0003 - .0005	.0005 - .0015	.0010 - .0020	.0010 - .0040
304, 310, 314, 316, 321, 330, 347, 348	< 35	90 - 125	80 - 120	.0005 - .0008	.0008 - .0020	.0010 - .0020	.0020 - .0050
	> 35	75 - 110	60 - 90	.0003 - .0005	.0005 - .0015	.0010 - .0015	.0010 - .0040
403, 410, 416, 420, 430F, 440C, 446	< 35	150 - 250	100 - 150	.0005 - .0010	.0008 - .0020	.0010 - .0030	.0020 - .0050
	> 35	125 - 175	80 - 150	.0003 - .0005	.0005 - .0015	.0010 - .0020	.0010 - .0040
High Temperature Alloys							
Cobalt Base							
Air-Resist, Haynes 21, 25, 36, 188, HS-21, L-605, NASA CO-W-RE, Powdered Metals, Stellite, X-40	< 35	150 - 250	100 - 150	.0005 - .0010	.0008 - .0020	.0010 - .0030	.0020 - .0050
	> 35	125 - 175	80 - 150	.0003 - .0005	.0005 - .0015	.0010 - .0020	.0010 - .0040
Nickel Base							
A286, Hastelloy, Inconel-625, 718, Invar, Kovar, Rene, Waspalloy	< 35	200 - 250	125 - 175	.0005 - .0010	.0008 - .0020	.0010 - .0030	.0020 - .0050
	> 35	150 - 200	100 - 150	.0003 - .0005	.0005 - .0015	.0010 - .0020	.0010 - .0040
Iron Base							
Carpenter 22-b3, Discaloy, Incoloy 800, 802, Multimet N-155, Timkin 16-25-6	< 35	200 - 250	125 - 175	.0005 - .0010	.0008 - .0020	.0010 - .0030	.0020 - .0050
	> 35	150 - 200	100 - 150	.0003 - .0005	.0005 - .0015	.0010 - .0020	.0010 - .0040

MATERIAL TYPES	SFM (Vc)				Cutter Diameter Chip Load per Tooth (Fz)			
	2 Flute (Stub / Std.)	2 Flute (Extra Lgh.)	3 / 4 Flute (Stub / Std.)	3 / 4 Flute (Extra Lgh.)	1/32 - 1/8	1/8 - 1/4	1/4 - 1/2	1/2 - 1
	Hardened Materials							
Monel								
Monel - 65% Nickel	175 - 300	125 - 175	175 - 300	125 - 175	.0007 - .0015	.0010 - .0025	.0015 - .0040	.0030 - .0060
Titanium Alloys								
ASTM 1, 2, 3, Commercially Pure, 6Al-25N-4Zr-2Mo-Si, 6Al-4V	200 - 300	125 - 250	200 - 300	125 - 250	.0007 - .0015	.0010 - .0025	.0015 - .0040	.0030 - .0060
Beta Titanium, 5553	-	-	200 - 300	125 - 200	.0005 - .0010	.0008 - .0020	.0010 - .0030	.0020 - .0050

For current pricing and availability please visit our website at www.micro100.com

The Machining Data shown below, is considered to be "safe starting conditions" and may need to be adjusted to obtain optimal tool performance.

SFM (Surface Feed per Minute) can be adjusted between 30%-50% on coated tools (depending on materials and workholding).

For plunging applications in solid materials, reduce feed rates by approximately 50%. Slotting applications, reduce feed by 20%.

Safety precautions must be implemented including safety glasses and machine shields to protect the operator and/or observers from hot flying chips.

Our Technical Team is ready to offer solutions for that difficult machining application. Whether you need tool specific speeds, feeds, depth of cuts, grade selection(s) or any questions and/or concerns regarding the application of MICRO 100 Solid Carbide Cutting Tools, they are there to help!

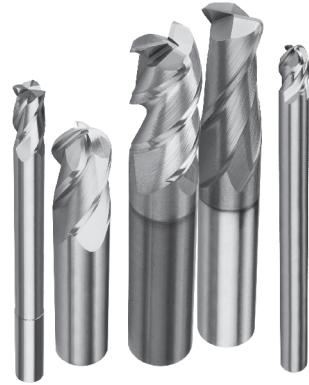

MATERIAL TYPES	M/Min (Vc)				Cutter Diameter Chip Load per Tooth (Fz)			
	2 Flute (Stub / Std.)	2 Flute (Extra Lgth.)	3 / 4 Flute (Stub / Std.)	3 / 4 Flute (Extra Lgth.)	1.0 - 3.0	3.0 - 6.0	6.0 - 12.0	12.0 - 25.0
Non-Ferrous Materials								
Aluminum / Aluminum Alloys								
2014, 2024, 2024, Aircraft Grade(s), 6061, 7075	90 - 150	90 -1 50	90 - 150	90 - 150	.025 - .050	.035 - .100	.050 - .150	.075 - .250
Brass / Bronze								
High Lead Brass, Red Brass, Yellow Brass, Naval Brass, Low Silicon Brass	90 - 120	60 - 90	75 - 115	60 - 90	.020 - .040	.025 - .065	.040 - .090	.050 - .200
Copper / Copper Alloys								
Aluminum Bronze, Low Silicon Bronze Beryllium Copper, Nickel Silver, Oxygen Free Copper	120 - 150	75 - 105	90 - 135	75 - 105	.0007 - .0015	.025 - .065	.040 - .090	.050 - .200
Composites								
Acrylics, Fiberglass, Glass Epoxy, Phenolics, Plastics	60 - 120	60 - 120	60 - 120	60 - 120	.025 - .050	.035 - .100	.050 - .150	.075 - .250
Graphites								
	90 - 200	90 - 200	90 - 200	90 - 200	.025 - .050	.035 - .100	.050 - .150	.075 - .250
Magnesium								
	90 - 150	90 - 150	90 - 150	90 - 150	.025 - .050	.035 - .100	.050 - .150	.075 - .250
Cast Materials / Irons								
Aluminum								
	75 - 105	75 - 105	75 - 105	75 - 105	.025 - .050	.035 - .100	.050 - .150	.075 - .250
Ductile Iron								
	60 - 90	35 - 60	60 - 90	35 - 60	.015 - .035	.025 - .075	.035 - .100	.050 - .200
Gray Iron								
	70 - 100	50 - 75	75 - 105	50 - 75	.025 - .050	.035 - .100	.050 - .150	.075 - .250
Steels								
	70 - 100	50 - 75	75 - 105	50 - 75	.025 - .050	.035 - .100	.050 - .150	.075 - .250

Technical Data

Variable 4-5 Flute,
V-Hemth End Mills



The Machining Data shown below, is considered to be "safe starting conditions" and may need to be adjusted to obtain optimal tool performance.

If "chatter" is present, increase Feed up to 20% and reduce RPM by 10% - 20%.

Safety precautions must be implemented including safety glasses and machine shields to protect the operator and/or observers from hot flying chips.

Our Technical Team is ready to offer solutions for that difficult machining application. Whether you need tool specific speeds, feeds, depth of cuts, grade selection(s) or any questions and/or concerns regarding the application of MICRO 100 Solid Carbide Cutting Tools, they are there to help!

MATERIAL TYPES	Type of Cut	Axial D.O.C.	Radial D.O.C.	No. of Flutes	SFM (Vc)	Cutter Diameter Chip Load per Tooth (Fz)						
						1/8	1/4	3/8	1/2	5/8	3/4	1
Cast Materials / Irons												
Gray Cast Irons												
	Slotting	D x 1	D x 1	4	400	.0006	.0012	.0019	.0025	.0031	.0038	.0050
	Roughing	D x 1.5	D x .5	4	500	.0007	.0015	.0023	.0030	.0037	.0046	.0060
	Roughing	D x 1.5	D x .5	5	500	-	.0014	.0021	.0028	.0035	.0043	.0056
	Finishing	D x 1.5	D x .01	5	650	-	.0014	.0021	.0028	.0035	.0043	.0056
Ductile Cast Irons												
	Slotting	D x 1	D x 1	4	300	.0006	.0012	.0018	.0023	.0029	.0035	.0046
	Roughing	D x 1.5	D x .5	4	400	.0007	.0014	.0021	.0028	.0035	.0042	.0056
	Roughing	D x 1.5	D x .5	5	400	-	.0013	.0020	.0027	.0033	.0040	.0054
	Finishing	D x 1.5	D x .01	5	520	-	.0013	.0020	.0027	.0033	.0040	.0054
Malleable Cast Irons												
	Slotting	D x .75	D x 1	4	250	.0004	.0008	.0012	.0015	.0019	.0023	.0030
	Roughing	D x 1	D x .75	4	325	.0005	.0011	.0016	.0022	.0027	.0033	.0044
	Roughing	D x 1	D x .75	5	325	-	.0010	.0015	.0021	.0026	.0032	.0042
	Finishing	D x 1.5	D x .01	5	425	-	.0010	.0015	.0021	.0026	.0032	.0042
Steels												
Low Carbon Steels												
≤38 HRc 1018, 12L14, 8620	Slotting	D x 1	D x 1	4	350	.0008	.0016	.0024	.0032	.0040	.0048	.0064
	Roughing	D x 1.5	D x .5	4	425	.0010	.0020	.0030	.0040	.0050	.0060	.0080
	Roughing	D x 1.5	D x .5	5	425	-	.0019	.0028	.0038	.0047	.0057	.0076
	Finishing	D x 1.5	D x .01	5	550	-	.0019	.0028	.0038	.0047	.0057	.0076
Medium Carbon Steels												
≤38 HRc 4140, 4340	Slotting	D x 1	D x 1	4	325	.0006	.0013	.0020	.0027	.0034	.0040	.0054
	Roughing	D x 1.5	D x .5	4	375	.0008	.0017	.0026	.0035	.0044	.0053	.0070
	Roughing	D x 1.5	D x .5	5	375	-	.0016	.0025	.0034	.0042	.0051	.0068
	Finishing	D x 1.5	D x .01	5	490	-	.0016	.0025	.0034	.0042	.0051	.0068
Tool & Die Steels												
≤38 HRc A2, D2, H13, P20	Slotting	D x 1	D x 1	4	325	.0006	.0013	.0020	.0027	.0034	.0040	.0054
	Roughing	D x 1.5	D x .5	4	375	.0008	.0017	.0026	.0035	.0044	.0053	.0070
	Roughing	D x 1.5	D x .5	5	375	-	.0016	.0025	.0034	.0042	.0051	.0068
	Finishing	D x 1.5	D x .01	5	485	-	.0016	.0025	.0034	.0042	.0051	.0068
Tool Steels												
>38 HRc	Slotting	D x 1	D x 1	4	225	.0005	.0010	.0015	.0020	.0025	.0030	.0040
	Roughing	D x 1.5	D x .5	4	275	.0006	.0012	.0017	.0023	.0029	.0035	.0046
	Roughing	D x 1.5	D x .5	5	275	-	.0011	.0016	.0022	.0028	.0034	.0044
	Finishing	D x 1.5	D x .01	5	355	-	.0011	.0016	.0022	.0028	.0034	.0044

For current pricing and availability please visit our website at www.micro100.com

The Machining Data shown below, is considered to be "safe starting conditions" and may need to be adjusted to obtain optimal tool performance.

If "chatter" is present, increase Feed up to 20% and reduce RPM by 10% - 20%.

Safety precautions must be implemented including safety glasses and machine shields to protect the operator and/or observers from hot flying chips.

Our Technical Team is ready to offer solutions for that difficult machining application. Whether you need tool specific speeds, feeds, depth of cuts, grade selection(s) or any questions and/or concerns regarding the application of MICRO 100 Solid Carbide Cutting Tools, they are there to help!



MATERIAL TYPES	Type of Cut	Axial D.O.C.	Radial D.O.C.	No. of Flutes	SFM (Vc)	Cutter Diameter Chip Load per Tooth (Fz)						
						1/8	1/4	3/8	1/2	5/8	3/4	1
Stainless Steels												
Steels - Easy Machining Difficulty												
302, 303, 410, 416	Slotting	D x 1	D x 1	4	300	.0006	.0012	.0019	.0025	.0031	.0038	.0050
	Roughing	D x 1.5	D x .5	4	375	.0007	.0015	.0023	.0030	.0037	.0046	.0060
	Roughing	D x 1.5	D x .5	5	375	-	.0014	.0021	.0028	.0035	.0043	.0056
	Finishing	D x 1.5	D x .01	5	485	-	.0014	.0021	.0028	.0035	.0043	.0056
Steels - Medium Machining Difficulty												
304, 316, Invar, Kovar	Slotting	D x .75	D x 1	4	275	.0006	.0012	.0019	.0025	.0031	.0038	.0050
	Roughing	D x 1.5	D x .5	4	350	.0007	.0015	.0023	.0030	.0037	.0046	.0060
	Roughing	D x 1.5	D x .5	5	350	-	.0014	.0021	.0028	.0035	.0043	.0056
	Finishing	D x 1.5	D x .01	5	450	-	.0014	.0021	.0028	.0035	.0043	.0056
Steels - Maximum Machining Difficulty												
13-8 PH, 15-5 PH, 17-4 PH, 316L	Slotting	D x .5	D x 1	4	250	.0006	.0012	.0019	.0025	.0031	.0038	.0050
	Roughing	D x 1	D x .5	4	300	.0007	.0015	.0023	.0030	.0037	.0046	.0060
	Roughing	D x 1	D x .5	5	300	-	.0014	.0021	.0028	.0035	.0043	.0056
	Finishing	D x 1.5	D x .01	5	390	-	.0014	.0021	.0028	.0035	.0043	.0056
Hardened Alloys												
Hard Temperature Alloys												
	Slotting	D x .25	D x 1	4	70	.0004	.0008	.0012	.0015	.0019	.0024	.0030
	Roughing	D x 1	D x .25	4	95	.0005	.0009	.0014	.0018	.0022	.0028	.0036
	Roughing	D x 1	D x .25	5	95	-	.0009	.0014	.0018	.0022	.0028	.0036
	Finishing	D x 1.5	D x .01	5	125	-	.0009	.0014	.0018	.0022	.0028	.0036
Titanium Alloys												
	Slotting	D x .5	D x 1	4	250	.0004	.0007	.0011	.0015	.0018	.0023	.0030
	Roughing	D x 1	D x .5	4	300	.0005	.0010	.0015	.0020	.0025	.0030	.0040
	Roughing	D x 1	D x .5	5	300	-	.0009	.0013	.0018	.0023	.0028	.0036
	Finishing	D x 1.5	D x .01	5	390	-	.0009	.0013	.0018	.0023	.0028	.0036



Hard Milling Guidelines for Miniature End Mills

Machining centers with rigid workholding (minimizing vibration) and balanced toolholders (providing T.I.R.) will optimize tool performance along with air/coolant for materials over 45 Rc.

To avoid chipping and/or breakage, slow the feedrate into the workpiece by ramping or helical interpolation. By utilizing the "Climb Milling" method, extended tool life and improved surface finish can be expected.

Machine RPM formula: $RPM = 3.82 \times SFM \div \text{Cutter Diameter}$

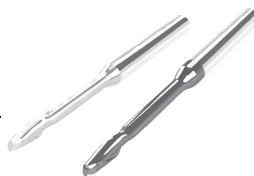

Material Hardness: 44-55 Rc / Reach: 1.5x to 5x

Cutter Diameter	SFM	IPT	RDOC	ADOC
.010	110	.00010	.0050	.0003
.015	110	.00010	.0050	.0003
.020	110	.00010	.0050	.0003
.025	190	.00025	.0110	.0006
.030	190	.00025	.0110	.0006
.031	190	.00025	.0110	.0006
.035	190	.00025	.0110	.0006
.040	290	.00040	.0160	.0009
.045	290	.00040	.0160	.0009
.047	290	.00040	.0160	.0009
.050	290	.00040	.0160	.0009
.060	360	.00050	.0220	.0012
.062	360	.00050	.0220	.0012
.075	430	.00065	.0270	.0016
.078	430	.00065	.0270	.0016
.090	470	.00075	.0330	.0019
.093	470	.00075	.0330	.0019
.125	580	.00090	.0440	.0025
.187	580	.00130	.0650	.0037
.250	580	.00160	.0880	.0050

Material Hardness: 44-55 Rc / Reach: 8x to 12x

Cutter Diameter	SFM	IPT	RDOC	ADOC
.010	90	.00010	.0050	.0002
.015	90	.00010	.0050	.0002
.020	90	.00010	.0050	.0002
.025	170	.00020	.0110	.0003
.030	170	.00020	.0110	.0003
.031	170	.00020	.0110	.0003
.035	170	.00020	.0110	.0003
.040	250	.00025	.0160	.0005
.045	250	.00025	.0160	.0005
.047	250	.00025	.0160	.0005
.050	250	.00025	.0160	.0005
.060	320	.00030	.0220	.0006
.062	320	.00030	.0220	.0006
.075	390	.00045	.0270	.0008
.078	390	.00045	.0270	.0008
.090	390	.00045	.0270	.0009
.093	430	.00055	.0330	.0009
.125	520	.00070	.0440	.0013
.187	520	.00100	.0650	.0019
.250	520	.00120	.0880	.0025

Material Hardness: 55-68 Rc / Reach: 1.5x to 5x

Cutter Diameter	SFM	IPT	RDOC	ADOC
.010	80	.00010	.0050	.0003
.015	80	.00010	.0050	.0003
.020	80	.00010	.0050	.0003
.025	140	.00020	.0080	.0006
.030	140	.00020	.0080	.0006
.031	140	.00020	.0080	.0006
.035	140	.00020	.0080	.0006
.040	210	.00030	.0120	.0009
.045	210	.00030	.0120	.0009
.047	210	.00030	.0120	.0009
.050	210	.00030	.0120	.0009
.060	270	.00040	.0160	.0012
.062	270	.00040	.0160	.0012
.075	320	.00050	.0200	.0016
.078	320	.00050	.0200	.0016
.090	350	.00055	.0230	.0019
.093	350	.00055	.0230	.0019
.125	420	.00070	.0310	.0025
.187	420	.00110	.0470	.0037
.250	420	.00150	.0630	.0050

Material Hardness: 55-68 Rc / Reach: 8x to 12x

Cutter Diameter	SFM	IPT	RDOC	ADOC
.010	70	.00010	.0040	.0002
.015	70	.00010	.0040	.0002
.020	70	.00010	.0040	.0002
.025	130	.00015	.0080	.0003
.030	130	.00015	.0080	.0003
.031	130	.00015	.0080	.0003
.035	130	.00015	.0080	.0003
.040	190	.00020	.0120	.0005
.045	190	.00020	.0120	.0005
.047	190	.00020	.0120	.0005
.050	190	.00020	.0120	.0005
.060	240	.00025	.0160	.0006
.062	240	.00025	.0160	.0006
.075	290	.00035	.0200	.0008
.078	290	.00035	.0200	.0008
.090	320	.00040	.0230	.0009
.093	320	.00040	.0230	.0009
.125	350	.00055	.0310	.0013
.187	350	.00090	.0470	.0019
.250	350	.00130	.0630	.0025

Hard Milling Guidelines for Miniature End Mills

Machining centers with rigid workholding (minimizing vibration) and balanced toolholders (providing T.I.R.) will optimize tool performance along with air/coolant for materials over 45 Rc.

To avoid chipping and/or breakage, slow the feedrate into the workpiece by ramping or helical interpolation. By utilizing the "Climb Milling" method, extended tool life and improved surface finish can be expected.

Machine RPM formula: $M/Min = RPM \times .00312 \times \text{Cutter Diameter}$

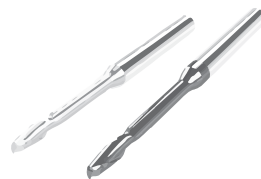

Material Hardness: 44-55 Rc / Reach: 1.5x to 5x

Cutter Diameter	M/Min	MMPT	ADOC
0.10	15	.0013	.0038
0.15	15	.0013	.0038
0.20	15	.0013	.0038
0.30	33	.0025	.0076
0.40	33	.0025	.0076
0.50	33	.0025	.0076
0.60	57	.0064	.0152
0.80	57	.0064	.0152
1.0	88	.0102	.0229
1.2	88	.0102	.0229
1.5	109	.0127	.0305
2.0	130	.0165	.0406
2.5	143	.0191	.0483
3.0	143	.0229	.0635
4.0	176	.0330	.0940
5.0	176	.0406	.1270

Material Hardness: 44-55 Rc / Reach: 8x to 12x

Cutter Diameter	M/Min	MMPT	ADOC
0.10	15	.0013	.0038
0.15	15	.0013	.0038
0.20	15	.0013	.0038
0.30	27	.0025	.0051
0.40	27	.0025	.0051
0.50	27	.0025	.0051
0.60	51	.0051	.0076
0.80	51	.0051	.0076
1.0	76	.0064	.0127
1.2	76	.0064	.0127
1.5	109	.0076	.0152
2.0	118	.0114	.0203
2.5	130	.0140	.0229
3.0	157	.0178	.0330
4.0	157	.0254	.0483
5.0	157	.0305	.0635

Material Hardness: 55-68 Rc / Reach: 1.5x to 5x

Cutter Diameter	M/Min	MMPT	ADOC
0.10	12	.0013	.0038
0.15	12	.0013	.0038
0.20	12	.0013	.0038
0.30	24	.0025	.0076
0.40	24	.0025	.0076
0.60	24	.0025	.0076
0.80	42	.0051	.0152
1.0	42	.0051	.0152
1.2	64	.0076	.0229
1.5	64	.0076	.0229
2.0	82	.0102	.0229
2.5	82	.0127	.0406
3.0	106	.0140	.0483
4.0	127	.0178	.0635
5.0	127	.0279	.0940

Material Hardness: 55-68 Rc / Reach: 8x to 12x

Cutter Diameter	M/Min	MMPT	ADOC
0.10	10	.0013	.0025
0.15	10	.0013	.0025
0.20	10	.0013	.0025
0.30	21	.0025	.0051
0.40	21	.0025	.0051
0.60	39	.0038	.0076
0.80	39	.0038	.0076
1.0	57	.0051	.0127
1.2	57	.0051	.0127
1.5	73	.0064	.0152
2.0	88	.0089	.0203
2.5	97	.0102	.0229
3.0	106	.0140	.0330
4.0	106	.0229	.0483
5.0	106	.0330	.0635

For current pricing and availability please visit our website at www.micro100.com



End Mills featuring high efficiency at speeds as low as 3,000 RPM and provide maximum performance at speeds of 10,000 RPM and higher!

Our flute designs are engineered to create less drag on the spindle and draw less power.

Applications for roughing and/or finishing can be accomplished with either low or high horsepower.

These selected families of End Mills provide maximum performance in following materials:

- | | |
|--------------------------------------|--------------------------|
| Aluminum Alloys | Die Cast Aluminum |
| High Silicon Aluminum | Extruded Metal Materials |
| Brass, Bronze, and Copper Alloys | Non-Ferrous Materials |
| Composites, Fiberglass, and Plastics | Magnesium Alloys |

MATERIAL TYPES	Type of Cut	Axial D.O.C.	Radial D.O.C.	No. of Flutes	SFM (Vc)	Cutter Diameter Chip Load per Tooth (Fz)						
						1/8	1/4	3/8	1/2	5/8	3/4	1
Materials												
Aluminum / Aluminum Alloys												
2024, 6061, 7075	Slotting	D x 1	D x 1	2	800	.0020	.0040	.0060	.0080	.0100	.0120	.0160
	Roughing	D x 1	D x .75	3	1000	.0020	.0050	.0075	.0100	.0120	.0150	.0200
	Finishing	D x 1.5	D x .01	3	1200	.0030	.0060	.0090	.0120	.0160	.0200	.0250
High Silicone Aluminum												
A380, A390	Slotting	D x 1	D x 1	3	400	.0010	.0020	.0030	.0040	.0050	.0060	.0080
	Roughing	D x 1	D x .75	3	600	.0015	.0030	.0045	.0060	.0075	.0090	.0120
	Finishing	D x 1.5	D x .01	3	800	.0018	.0035	.0055	.0070	.0090	.0110	.0140
Brass / Bronze / Copper Alloys												
High Lead Brass, Red Brass, Yellow Brass, Naval Brass, Low Silicon Brass, Beryllium Copper, Nickel Silver, Oxygen Free Copper	Slotting	D x .75	D x 1	2	400	.0010	.0020	.0030	.0040	.0050	.0060	.0080
	Roughing	D x 1	D x .75	3	475	.0012	.0025	.0037	.0050	.0063	.0075	.0100
	Finishing	D x 1.5	D x .01	3	550	.0015	.0030	.0045	.0060	.0075	.0090	.0120
Composites, Fiberglass, Plastics												
Acrylics, Fiberglass, Glass Epoxy, Phenolics, Plastics	Slotting	D x 1	D x 1	3	400	.0010	.0020	.0030	.0040	.0050	.0060	.0080
	Roughing	D x 1	D x .75	3	600	.0015	.0030	.0045	.0060	.0075	.0090	.0120
	Finishing	D x 1.5	D x .01	3	800	.0018	.0035	.0055	.0070	.0090	.0110	.0140
Magnesium Alloys												
	Slotting	D x 1	D x 1	2	800	.0020	.0040	.0060	.0080	.0100	.0120	.0160
	Roughing	D x 1	D x .75	3	1000	.0020	.0050	.0075	.0100	.0120	.0150	.0200
	Finishing	D x 1.5	D x .01	3	1200	.0030	.0060	.0090	.0120	.0160	.0200	.0250

The Machining Data shown below, is considered to be "safe starting conditions" and may need to be adjusted to obtain optimal tool performance.

Safety precautions must be implemented including safety glasses and machine shields to protect the operator and/or observers from hot flying chips.

Our Technical Team is ready to offer solutions for that difficult machining application. Whether you need tool specific speeds, feeds, depth of cuts, grade selection(s) or any questions and/or concerns regarding the application of MICRO 100 Solid Carbide Cutting Tools, they are there to help!

For current pricing and availability please visit our website at www.micro100.com

End Mills featuring high efficiency at speeds as low as 3,000 RPM and provide maximum performance at speeds of 10,000 RPM and higher!

Our flute designs are engineered to create less drag on the spindle and draw less power.

Applications for roughing and/or finishing can be accomplished with either low or high horsepower.

These selected families of End Mills provide maximum performance in following materials:

Aluminum Alloys
High Silicon Aluminum
Brass, Bronze, and Copper Alloys
Composites, Fiberglass, and Plastics

Die Cast Aluminum
Extruded Metal Materials
Non-Ferrous Materials
Magnesium Alloys



MATERIAL TYPES	Type of Cut	Axial D.O.C.	Radial D.O.C.	No. of Flutes	M/Min (Vc)	Cutter Diameter Chip Load per Tooth (Fz)						
						3	6	9	12	16	20	25
Non-Ferrous Materials												
Aluminum / Aluminum Alloys												
2024, 6061, 7075	Slotting	D x 1	D x 1	2	243	.051	.102	.152	.203	.254	.305	.406
	Roughing	D x 1	D x .75	3	304	.051	.0050	.191	.254	.305	.381	.508
	Finishing	D x 1.5	D x .01	3	365	.076	.0060	.229	.305	.406	.0200	.635
High Silicone Aluminum												
A380, A390	Slotting	D x 1	D x 1	3	122	.025	.051	.076	.102	.127	.152	.203
	Roughing	D x 1	D x .75	3	182	.038	.076	.114	.152	.191	.229	.305
	Finishing	D x 1.5	D x .01	3	243	.046	.089	.140	.178	.229	.279	.356
Brass / Bronze / Copper Alloys												
High Lead Brass, Red Brass, Yellow Brass, Naval Brass, Low Silicon Brass, Beryllium Copper, Nickel Silver, Oxygen Free Copper	Slotting	D x .75	D x 1	2	122	.025	.051	.076	.102	.127	.152	.203
	Roughing	D x 1	D x .75	3	144	.031	.064	.094	.127	.160	.191	.254
	Finishing	D x 1.5	D x .01	3	167	.038	.076	.114	.152	.191	.229	.305
Composites, Fiberglass, Plastics												
Acrylics, Fiberglass, Glass Epoxy, Phenolics, Plastics	Slotting	D x 1	D x 1	3	122	.025	.051	.076	.102	.127	.152	.203
	Roughing	D x 1	D x .75	3	182	.038	.076	.114	.152	.191	.229	.305
	Finishing	D x 1.5	D x .01	3	243	.046	.089	.140	.178	.229	.279	.365
Magnesium Alloys												
	Slotting	D x 1	D x 1	2	243	.051	.102	.152	.203	.254	.305	.406
	Roughing	D x 1	D x .75	3	304	.051	.127	.191	.254	.305	.381	.508
	Finishing	D x 1.5	D x .01	3	365	.076	.152	.229	.305	.406	.508	.635

The Machining Data shown below, is considered to be "safe starting conditions" and may need to be adjusted to obtain optimal tool performance.

Safety precautions must be implemented including safety glasses and machine shields to protect the operator and/or observers from hot flying chips.

Our Technical Team is ready to offer solutions for that difficult machining application. Whether you need tool specific speeds, feeds, depth of cuts, grade selection(s) or any questions and/or concerns regarding the application of MICRO 100 Solid Carbide Cutting Tools, they are there to help!

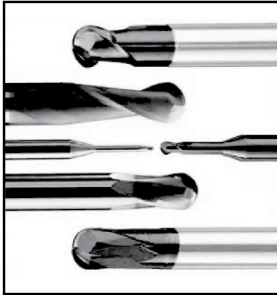

Ball Nose Milling Recommendations

- Maximum Depth of Cut (DOC) should be "less than or equal to" 10% of the cutter diameter for finishing applications.
- "Stepover" should be "greater than or equal to" the Depth of Cut (DOC).
- For roughing applications, the recommended maximum Width of Cut (WOC) and the Depth of Cut (DOC) should be 30% of the cutter diameter.
- Feed per Revolution (FPR) should begin at 1% of the cutter diameter.
- Climb Milling methods are preferred.
- When plunging with a ball nose end mill, a "pecking" cycle is recommended with a maximum of .0002 (.05mm) Feed per Revolution (FPR) and a depth of 30% of the cutter diameter.
- Decreasing feed rates when machining into corners will reduce chatter and improve surface finishes.

Ball Nose End Mills are designed, engineered, and manufactured for machining 3-dimensional contour shapes and geometries. There are two (2) common methods of utilizing ball nose end mills. The most common is the 90° method and some use the 15° "tilt" method.

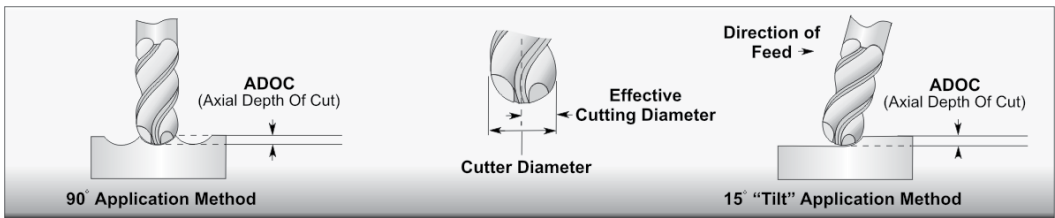

Optimum tool life and performance can be obtained by using the 90° application method and two (2) simple steps as listed below:



For current pricing and availability please visit our website at www.micro100.com

Calculate the "Effective Cutting Diameter"

Utilized when the ADOC is less than the full radius of the ball nose end mill.

$$\text{Effective Cutting Diameter} = 2 \times \sqrt{R^2 - \text{ADOC}^2}$$

Calculate the "Velocity Adjustment"

When utilizing "less than" the cutter diameter, the RPM will need to be adjusted slightly higher.

$$\text{Velocity Adjustment} = \frac{\text{SFM} \times 3.82}{\text{Effective Cutting Diameter}}$$



Cutter Diameters	Effective Cutting Diameter for common Axial Depth of Cuts (90° Method)															
	.010	.020	.030	.050	.070	.090	.120	.150	.180	.220	.260	.300	.350	.400	.450	.500
1/8	.068	.092	.107													
1/4	.098	.136	.162	.200	.224	.240										
3/8	.121	.169	.203	.255	.292	.320	.350	.367	.375							
1/2	.140	.196	.237	.300	.347	.384	.427	.458	.480	.496	.500					
5/8	.157	.220	.267	.339	.394	.439	.492	.534	.566	.597	.616	.624				
3/4	.172	.242	.294	.374	.436	.487	.550	.600	.641	.683	.714	.735	.758			
1	.199	.280	.341	.436	.510	.572	.650	.714	.768	.828	.877	.917	.954	.980	.995	1.000

Refer to next page for more Ball Nose End Mill Technical Data / Information.

For applications requiring the 15° "tilt" application method, it's recommended to utilize ball nose end mills on an incline (β) to avoid "0" SFM condition at the center of the end mill. This will increase tool life and performance while producing acceptable finish on the parts. Feed the end mill in the direction of the incline while utilizing the "climb milling" technique.

Calculate the "Effective Cutting Diameter"

Utilized when the ADOC is less than the full radius of the ball nose end mill.

$$\text{Effective Cutting Diameter} = D \times \sin \left[\beta \pm \left(\frac{D - 2 \times \text{ADOC}}{\text{Cutter Diameter}} \right) \right]$$

Calculate the "Velocity Adjustment"

When utilizing "less than" the cutter diameter, the RPM will need to be adjusted slightly higher.

$$\text{Velocity Adjustment} = \frac{\text{SFM} \times 3.82}{\text{Effective Cutting Diameter}}$$



Cutter Diameters	Effective Cutting Diameter for common Axial Depth of Cuts (15° "Tilt" Method)															
	.010	.020	.030	.050	.070	.090	.120	.150	.180	.220	.260	.300	.350	.400	.450	.500
1/8	.093	.092	.120	.125	.116											
1/4	.154	.185	.206	.232	.245	.249	.243									
3/8	.208	.249	.278	.317	.343	.360	.373	.374	.366							
1/2	.259	.308	.343	.393	.454	.384	.479	.494	.499	.495	.477					
5/8	.308	.363	.404	.463	.506	.539	.575	.599	.615	.624	.622	.610				
3/4	.355	.242	.294	.374	.436	.487	.550	.550	.641	.683	.714	.735	.748			
1	.199	.280	.341	.436	.510	.572	.650	.650	.768	.828	.877	.917	.954	.980	.995	1.000

The above data are recommendations and when applied may need to be adjusted to obtain maximum tool performance.



Hard Milling Guidelines for Miniature End Mills

Machining centers with rigid workholding (minimizing vibration) and balanced toolholders (providing T.I.R.) will optimize tool performance along with air/coolant for materials over 45 Rc.

To avoid chipping and/or breakage, slow the feedrate into the workpiece by ramping or helical interpolation. By utilizing the "Climb Milling" method, extended tool life and improved surface finish can be expected.

Machine RPM formula: $RPM = 3.82 \times SFM \div \text{Cutter Diameter}$

Material Hardness: 44-55 Rc / Reach: 1.5x to 5x			
Cutter Diameter	SFM	IPT	ADOC
.010	140	.0002	.0006
.015	140	.0002	.0006
.020	140	.0002	.0006
.025	140	.0002	.0006
.030	250	.0005	.0012
.031	250	.0005	.0012
.035	250	.0005	.0012
.040	250	.0005	.0012
.045	360	.0008	.0019
.047	360	.0008	.0019
.050	360	.0008	.0019
.060	450	.0010	.0025
.062	450	.0010	.0025
.075	530	.0013	.0031
.078	530	.0013	.0031
.090	580	.0015	.0037
.093	580	.0015	.0037
.125	750	.0018	.0050
.187	750	.0028	.0075
.250	750	.0038	.0100

Material Hardness: 44-55 Rc / Reach: 8x to 12x			
Cutter Diameter	SFM	IPT	ADOC
.010	120	.0001	.0002
.015	120	.0001	.0002
.020	120	.0001	.0002
.025	120	.0004	.0002
.030	220	.0004	.0005
.031	220	.0004	.0005
.035	220	.0004	.0005
.040	220	.0004	.0005
.045	320	.0005	.0007
.047	320	.0005	.0007
.050	320	.0005	.0007
.060	420	.0006	.0009
.062	420	.0006	.0009
.075	490	.0009	.0012
.078	490	.0009	.0012
.090	540	.0011	.0014
.093	540	.0011	.0014
.125	650	.0014	.0019
.187	650	.0023	.0028
.250	650	.0032	.0032

Material Hardness: 55-68 Rc / Reach: 1.5x to 5x			
Cutter Diameter	SFM	IPT	ADOC
.010	140	.0002	.0006
.015	140	.0002	.0006
.020	140	.0002	.0006
.025	140	.0002	.0006
.030	250	.0004	.0012
.031	250	.0004	.0012
.035	250	.0004	.0012
.040	250	.0004	.0012
.045	360	.0006	.0019
.047	360	.0006	.0019
.050	360	.0006	.0019
.060	450	.0008	.0025
.062	450	.0008	.0025
.075	530	.0010	.0031
.078	530	.0010	.0031
.090	580	.0011	.0037
.093	580	.0011	.0037
.125	600	.0014	.0050
.187	600	.0021	.0075
.250	600	.0028	.0100

Material Hardness: 55-68 Rc / Reach: 8x to 12x			
Cutter Diameter	SFM	IPT	ADOC
.010	120	.0001	.0002
.015	120	.0001	.0002
.020	120	.0001	.0002
.025	120	.0001	.0002
.030	220	.0003	.0005
.031	220	.0003	.0005
.035	220	.0003	.0005
.040	220	.0003	.0005
.045	320	.0004	.0007
.047	320	.0004	.0007
.050	320	.0004	.0007
.060	420	.0005	.0009
.062	420	.0005	.0009
.075	490	.0007	.0012
.078	490	.0007	.0012
.090	540	.0008	.0014
.093	540	.0008	.0014
.125	580	.0011	.0019
.187	580	.0016	.0028
.250	580	.0022	.0038

For current pricing and availability please visit our website at www.micro100.com

Hard Milling Guidelines for Miniature End Mills

Machining centers with rigid workholding (minimizing vibration) and balanced toolholders (providing T.I.R.) will optimize tool performance along with air/coolant for materials over 45 Rc.

To avoid chipping and/or breakage, slow the feedrate into the workpiece by ramping or helical interpolation. By utilizing the "Climb Milling" method, extended tool life and improved surface finish can be expected.

Machine RPM formula: $M/Min = RPM \times .00312 \times D$ (Cutter Diameter)

Material Hardness: 44-55 Rc / Reach: 1.5x to 5x			
Cutter Diameter	M/Min	MMPT	ADOC
0.2	42	.0051	.0006
0.3	42	.0051	.0006
0.4	42	.0051	.0006
0.5	76	.0127	.0305
0.6	76	.0127	.0305
0.8	76	.0127	.0305
1.0	109	.0203	.0483
1.2	109	.0203	.0483
1.5	133	.0254	.0635
2.0	161	.0330	.0787
2.5	176	.0381	.0940
3.0	227	.0457	.1270
4.0	227	.0711	.1905
5.0	227	.0965	.2540

Material Hardness: 44-55 Rc / Reach: 1.5x to 5x			
Cutter Diameter	M/Min	MMPT	ADOC
0.2	36	.0025	.0051
0.3	36	.0025	.0051
0.4	36	.0025	.0051
0.5	61	.0102	.0127
0.6	61	.0102	.0127
0.8	61	.0102	.0127
1.0	97	.0127	.0178
1.2	97	.0127	.0178
1.5	127	.0152	.0229
2.0	148	.0229	.0305
2.5	167	.0279	.0356
3.0	197	.0356	.0483
4.0	197	.0584	.0711
5.0	197	.0813	.0813

Material Hardness: 56-68 Rc / Reach: 1.5x to 5x			
Cutter Diameter	M/Min	MMPT	ADOC
0.2	42	.0051	.0127
0.3	42	.0051	.0127
0.4	42	.0051	.0127
0.5	76	.0102	.0305
0.6	76	.0102	.0305
0.8	76	.0102	.0305
1.0	109	.0152	.0483
1.2	109	.0152	.0483
1.5	133	.0203	.0635
2.0	161	.0254	.0787
2.5	176	.0279	.0940
3.0	182	.0356	.1270
4.0	182	.0534	.1905
5.0	182	.0711	.2540

Material Hardness: 56-68 Rc / Reach: 8x to 12x			
Cutter Diameter	M/Min	MMPT	ADOC
0.2	36	.0025	.0051
0.3	36	.0025	.0051
0.4	36	.0025	.0051
0.5	61	.0076	.0127
0.6	61	.0076	.0127
0.8	61	.0076	.0127
1.0	99	.0102	.0178
1.2	99	.0102	.0178
1.5	127	.0127	.0229
2.0	148	.0178	.0305
2.5	164	.0203	.0356
3.0	176	.0279	.0483
4.0	176	.0381	.0711
5.0	176	.0559	.0965



Carbide End Mill Trouble Shooting Guide
for Problems, Causes, and Recommended Solutions.

Problems	Causes	Recommended Solutions
Chipping	Feed Rate is too fast on first cut. Feed Rate is too fast. Lack of rigidity (machine & toolholder). Lack of rigidity (tool). Tool corner is too sharp. Tool edges chipping	Reduce Feed Rate on first pass. Reduce Feed Rate. Utilize machine and toolholder that has better rigidity. Use a shorter end mill, try climb milling. Use end mill with radius if applicable. Use end mill with radius if applicable.
Chattering	Feed and Speed is too fast. Lack of rigidity (machine & toolholder). Too much relief angle. Cut is too deep. Flute length too long. Too much overhang.	Correct Feeds and Speeds. Utilize machine and toolholder that has better rigidity. Change to end mill with a smaller relief angle. Decrease width and depth of cut. Use a shorter end mill. Hold end mill shank deeper in toolholder.
Excessive Wear	Speed is too fast. Hard work material. Improper speed and feed (too slow). Wrong helix angle. Primary relief angle (too large). Re-cutting chips.	Decrease spindle speed and use more coolant. Utilize coated end mills. Increase feeds and speeds (try down cut). Change to end mill with appropriate helix angle. Select end mill with smaller relief angle. Change feed and speed to change chip size (use more coolant/air to clear chips).
Leaving Burrs	Too much wear on primary angle. Incorrect feeds and speeds. Wrong helix angle.	Change end mill sooner. Correct cutting parameters. Change to end mill with appropriate helix angle.
Poor Finish	Feed rate is too fast. Milling speed is too slow. Too much tool wear. Recutting chips.	Reduce feed rate. Increase RPM. Change tool sooner. Change feed and speed to change chip size (use more coolant/air to clear chips).
Chip Packing	Cut is too heavy. Not enough chip clearance. Not enough coolant/air.	Decrease width and depth of cut. Use end mill with less flutes. Higher coolant pressure and direct nozzle to point if cut or use air.
Short Tool Life	Cutting friction is too great. Hard work material, Improper helix and relief angle.	Check feed rate, speed and change end mill sooner. Use coated end mills. Change to end mill with appropriate helix and relief angles.
No Dimensional Accuracy	Cut is too heavy. Lack of accuracy (machine/toolholder). Not enough rigidity (machine/toolholder). Not sufficient number of flutes.	Decrease width and depth of cut. Repair machines/toolholder. Change machine/toolholder or milling parameters. Use multi-flute end mills.
No Perpendicular Side	Feed is too fast. Cutting amount is too great. Flute length too long. Not sufficient number of flutes.	Decrease feed rate. Reduce depth of cuts. Change to shorter end mill. Use multi-flute end mills.
Breakage	Feed is too fast. Cutting amount is too great. Overhang of end mill is too much. Wear is too much.	Reduce feed rate. Reduce width and depth of cuts. Hold end mill shank deeper in toolholder or use shorter end mill. Check feed rate, speed, and method of milling.
Welding or Galling	Cutting speed is too low. End Mill not sharp enough.	Increase surface feet per minute. Change end mill.

Please contact our Technical Department for more information.

For current pricing and availability please visit our website at www.micro100.com

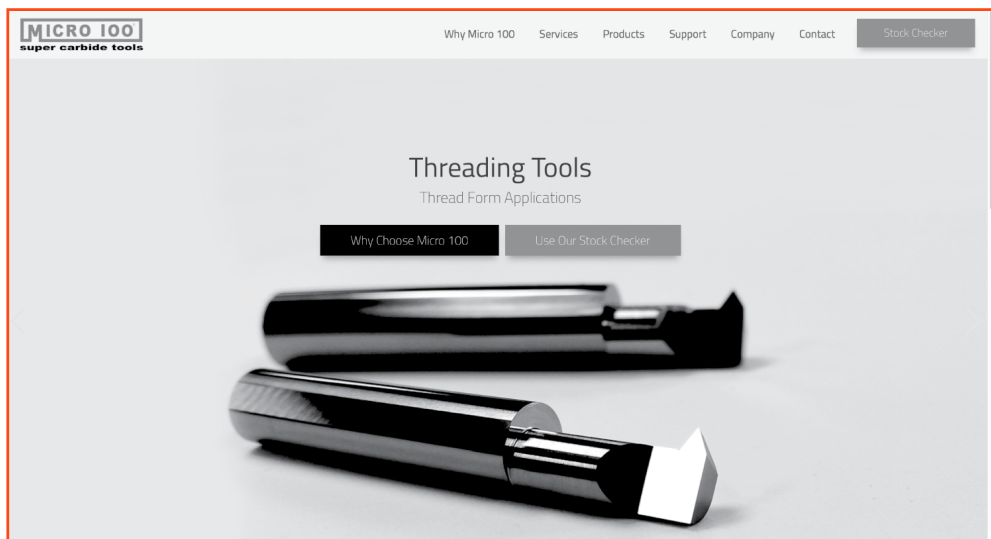

MICRO 100 offers several programming Excel Spreadsheets for Thread Milling.
Visit our website at: www.micro100.com and "click" on the "Support" tab.

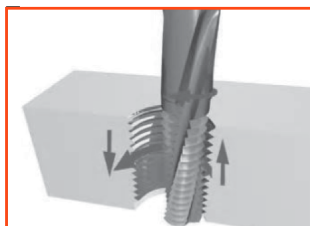

- Single Profile Thread Mill Assist Program
- 2-Pass Thread Mill Assist Program for UN Threads
- Thread Mill Assist Program for NPT & NPTF Threads
- Metric Thread Program
- Multiple Profile Thread Mill Assist Program for UN Threads

Our easy to use spreadsheets are designed to "maximize" your single point thread milling performance. Creates G-Code programs to fit your particular threading application needs.



THREAD MILLS
featuring:
UN Helical Flute Design
NPT Helical Flute Design
NPTF Helical Flute Design
Precision O.D. & I.D. Thread Mills
Thread forms generated in American Standard





MATERIAL TYPES	RPM	IPM	RPM	IPM	RPM	IPM	RPM	IPM
Aluminum / Aluminum Alloys	3000	4.5	6000	9	7500	12	10000	15
Brass / Bronze	3000	4.5	6000	9	7500	12	10000	15
Copper / Copper Alloys	3000	4.5	6000	9	7500	12	10000	15
Magnesium /Magnesium Alloys	3000	4.5	6000	9	7500	12	10000	15
Glass Filled / Phenolics / Plastics	3000	4.5	6000	9	7500	12	10000	15
Cast Irons / Soft	3000	4.5	6000	9	7500	12	10000	15
Cast Irons / Hard	3000	2.4	6000	4.8	7500	6	10000	8
Ductile Iron	3000	3	6000	6	7500	7.5	10000	10
Malleable Iron	3000	3	6000	6	7500	7.5	10000	10
Low Carbon Steel	3000	3	6000	6	7500	7.5	10000	10
Medium Carbon Steel	3000	4.5	6000	9	7500	11.3	10000	15
Hardened Steel	3000	1.5	6000	3	7500	3.8	10000	5
Stainless Steel / Soft	3000	3	6000	6	7500	7.5	10000	10
Stainless Steel / Hard	3000	1.5	6000	3	7500	3.8	10000	5
Monel	3000	3	6000	6	7500	7.5	10000	10
High Nickel Steel	3000	1.5	6000	3	7500	3.8	10000	5
Nickel Base High Temperature Alloys	3000	1.5	6000	3	7500	3.8	10000	5
Titanium / Soft	3000	3	6000	6	7500	7.5	10000	10
Titanium / Hard	3000	1.5	6000	3	7500	3.8	10000	5

To achieve "Optimal Engraving Tool Performance", variations to the machining data shown above may be required. The data given, is considered to be "safe starting conditions".

Plunge Feed to Depth at 50% of feed rates (shown above for the material being machined).

To reduce tool breakage on harder materials or if sharper points are being utilized, reduce feed rates by as much as 50% and take shallower passes (0.001" per depth of pass is recommended).

To extend tool life, coolant is recommended. The use of coolant also reduces "build up" on the tool's edge.

When engraving lines appear to be "rough and/or jagged", this condition is generally caused by a dull tool or a tool with edge "build up". This type of "build up" mostly occurs in materials such as aluminum, brass, and copper.

When feed rates and/or depths of cuts are too fast, these conditions may not allow the material to be cleanly machined. Making a "finish" pass with a depth of cut (0.001" - 0.002") and a reduced feed rate will provide a solution for the "burred or jagged" edges.





MATERIAL TYPES	RPM	MM/MIn	RPM	MM/MIn	RPM	MM/MIn	RPM	MM/MIn
Aluminum / Aluminum Alloys	3000	114	6000	228	7500	304	10000	381
Brass / Bronze	3000	114	6000	228	7500	304	10000	381
Copper / Copper Alloys	3000	114	6000	228	7500	304	10000	381
Magnesium / Magnesium Alloys	3000	114	6000	228	7500	304	10000	381
Glass Filled / Phenolics / Plastics	3000	114	6000	228	7500	304	10000	381
Cast Irons / Soft	3000	114	6000	228	7500	304	10000	381
Cast Irons / Hard	3000	61	6000	122	7500	152	10000	203
Ductile Iron	3000	76	6000	152	7500	191	10000	254
Malleable Iron	3000	76	6000	152	7500	191	10000	254
Low Carbon Steel	3000	76	6000	152	7500	191	10000	254
Medium Carbon Steel	3000	114	6000	229	7500	287	10000	381
Hardened Steel	3000	38	6000	76	7500	97	10000	127
Stainless Steel / Soft	3000	76	6000	152	7500	191	10000	254
Stainless Steel / Hard	3000	38	6000	76	7500	97	10000	127
Monel	3000	76	6000	152	7500	191	10000	254
High Nickel Steel	3000	38	6000	76	7500	97	10000	127
Nickel Base High Temperature Alloys	3000	38	6000	76	7500	97	10000	127
Titanium / Soft	3000	76	6000	152	7500	191	10000	254
Titanium / Hard	3000	38	6000	76	7500	97	10000	127

To achieve "Optimal Engraving Tool Performance", variations to the machining data shown above may be required. The data given, is considered to be "safe starting conditions".

Plunge Feed to Depth at 50% of feed rates (shown above for the material being machined).

To reduce tool breakage on harder materials or if sharper points are being utilized, reduce feed rates by as much as 50% and take shallower passes (0.001" per depth of pass is recommended).

To extend tool life, coolant is recommended. The use of coolant also reduces "build up" on the tool's edge.

When engraving lines appear to be "rough and/or jagged", this condition is generally caused by a dull tool or a tool with edge "build up". This type of "build up" mostly occurs in materials such as aluminum, brass, and copper.

When feed rates and/or depths of cuts are too fast, these conditions may not allow the material to be cleanly machined. Making a "finish" pass with a depth of cut (0.001" - 0.002") and a reduced feed rate will provide a solution for the "burred or jagged" edges.

Product Guarantees / Warranties

MICRO 100 Tool Corporation will replace any of our products that, after a quality control check, have been deemed "defective" due to material(s) and/or manufacturing processes. The provisions of this guarantee and/or warranty will not apply to any product(s) manufactured by **MICRO 100** Tool Corporation that has been subject to misuse including but not limited to, utilizing tools in regards to "safe starting conditions", and resharpener or altering the tool(s) from the original manufacturing processes.

Sales / Distribution Channels

MICRO 100 Tool Corporation products are sold exclusively through a carefully selected network of Authorized Distributors throughout the United States and Worldwide. We have a highly knowledgeable sales team made up of a Vice President Sales & Marketing, Regional Managers, and Manufacturer Representatives. Our Sales Team and Distributor Partners are ready to help you solve most machining applications.

Damaged Shipments

Upon receiving damaged products, **MICRO 100** Tool Corporation instructs the receiver to keep the original packaging intact and take pictures. Contact our Customer Service Department immediately so that we can begin the process of getting product replacements and start claim proceedings with the carrier.

Product Returns

No products will be accepted without a Returned Material Authorization Form (RMA). All products returned must have been purchased within one (1) year and in unused condition with original packaging. A "restocking fee" may be applicable; contact **MICRO 100** Customer Service Department for further details and instructions.

Transportation

All shipments are shipped FOB factory and our primary carrier is UPS.
Please contact our Customer Service Department with any questions and/or concerns.

MICRO 100 Tool Corporation has no control over conditions for which the products we manufacture may be subjected to. It is highly recommended that the user(s) of any product(s) manufactured by **MICRO 100** Tool Corporation abide by and follow the guidelines and/or standards in regard to the type of machinery our products will be used on and that common safety practices and precautions be enforced.

During machining applications, "hot flying" chips may be projected from the workpiece or a rotating part of the machine. If carbide tool material is subjected to "over-stress" and/or "severe impact", it may fracture causing small fragments to be dispelled. For such instances, precautionary safety methods must be implemented to protect the machine operator(s) and/or observer(s). These safety measures may include but not be limited to, appropriate safety glasses with wrap around eye protection and/or safety shields to protect everyone in the immediate area of where the machining operations are being performed.

Grinding products listed in this catalog and/or any other literature produced by **MICRO 100** Tool Corporation, will produce a dust/mist that may be hazardous. Ask for your copy of our Material Safety Data Sheets, that contain vital information for the product(s).

Designs, Specifications, and/or Pricing of any products manufactured and sold by **MICRO 100** Tool Corporation are subject to change without notice. Any modification(s) of the product(s) by the customer will void any guarantees and/or warranties.

The material appearing herein, is the exclusive property of **MICRO 100** Tool Corporation, and may not be reproduced, duplicated, and/or copied in any manner in whole or in part or used for furnishing information to others for any purposes of which may be detrimental to the interest of **MICRO 100** Tool Corporation. **MICRO 100** Tool Corporation further reserves the rights in and to the information contained herein.

MICRO 100 Tool Corporation is the owner of the following Registered Trademark ® **MICRO 100**